

Industrial Automation Headquarters

Delta Electronics, Inc.
Taoyuan Technology Center
No.18, Xinglong Rd., Taoyuan District,
Taoyuan City 33068, Taiwan
TEL: 886-3-362-6301 / FAX: 886-3-371-6301

Asia

Delta Electronics (Shanghai) Co., Ltd.
No.182 Minyu Rd., Pudong Shanghai, P.R.C.
Post code : 201209
TEL: 86-21-6872-3988 / FAX: 86-21-6872-3996
Customer Service: 400-820-9595

Delta Electronics (Japan), Inc.
Tokyo Office
Industrial Automation Sales Department
2-1-14 Shibadaiimon, Minato-ku
Tokyo, Japan 105-0012
TEL: 81-3-5733-1155 / FAX: 81-3-5733-1255

Delta Electronics (Korea), Inc.
Seoul Office
1511, 219, Gasan Digital 1-Ro., Geumcheon-gu,
Seoul, 08501 South Korea
TEL: 82-2-515-5305 / FAX: 82-2-515-5302

Delta Energy Systems (Singapore) Pte Ltd.
4 Kaki Bukit Avenue 1, #05-04, Singapore 417939
TEL: 65-6747-5155 / FAX: 65-6744-9228

Delta Electronics (India) Pvt. Ltd.
Plot No.43, Sector 35, HSIIDC Gurgaon,
PIN 122001, Haryana, India
TEL: 91-124-4874900 / FAX : 91-124-4874945

Delta Electronics (Thailand) PCL.
909 Soi 9, Moo 4, Bangpoo Industrial Estate (E.P.Z),
Pattana 1 Rd., T.Phraksa, A.Muang,
Samutprakarn 10280, Thailand
TEL: 66-2709-2800 / FAX : 662-709-2827

Delta Energy Systems (Australia) Pty Ltd.
Unit 20-21/45 Normanby Rd., Notting Hill Vic 3168, Australia
TEL: 61-3-9543-3720

Americas

Delta Electronics (Americas) Ltd.
Raleigh Office
P.O. Box 12173, 5101 Davis Drive,
Research Triangle Park, NC 27709, U.S.A.
TEL: 1-919-767-3813 / FAX: 1-919-767-3969

Delta Greentech (Brasil) S/A
São Paulo Office
Rua Itapeva, 26 – 3° Andar - Bela Vista
CEP: 01332-000 – São Paulo – SP - Brasil
TEL: 55-11-3530-8642 / 55-11-3530-8640

Delta Electronics International Mexico S.A. de C.V.
Mexico Office
Via Dr. Gustavo Baz No. 2160, Colonia La Loma,
54060 Tlalnepantla Estado de Mexico
TEL: 52-55-2628-3015 #3050/3052

EMEA

Headquarters: Delta Electronics (Netherlands) B.V.
Sales: Sales.IA.EMEA@deltaww.com
Marketing: Marketing.IA.EMEA@deltaww.com
Technical Support: iatechnicalsupport@deltaww.com
Customer Support: Customer-Support@deltaww.com
Service: Service.IA.emea@deltaww.com
TEL: +31(0)40 800 3800

BENELUX: Delta Electronics (Netherlands) B.V.
De Witbogt 20, 5652 AG Eindhoven, The Netherlands
Mail: Sales.IA.Benelux@deltaww.com
TEL: +31(0)40 800 3800

DACH: Delta Electronics (Netherlands) B.V.
Coesterweg 45, D-59494 Soest, Germany
Mail: Sales.IA.DACH@deltaww.com
TEL: +49(0)2921 987 0

France: Delta Electronics (France) S.A.
ZI du bois Challand 2, 15 rue des Pyrénées,
Lisses, 91090 Evry Cedex, France
Mail: Sales.IA.FR@deltaww.com
TEL: +33(0)1 69 77 82 60

Iberia: Delta Electronics Solutions (Spain) S.L.U
Ctra. De Villaverde a Vallecas, 265 1º Dcha Ed.
Hormigueras – P.I. de Vallecas 28031 Madrid
TEL: +34(0)91 223 74 20
C/Lluïa, 321-329 (Edifici CINC) | 22@Barcelona, 08019 Barcelona
Mail: Sales.IA.Iberia@deltaww.com
TEL: +34 93 303 00 60

Italy: Delta Electronics (Italy) S.r.l.
Ufficio di Milano Via Senigallia 18/2 20161 Milano (MI)
Piazza Grazioli 18 00186 Roma Italy
Mail: Sales.IA.Italy@deltaww.com
TEL: +39 02 64672538

Russia: Delta Energy System LLC
Vereyskaya Plaza II, office 112 Vereyskaya str.
17 121357 Moscow Russia
Mail: Sales.IA.RU@deltaww.com
TEL: +7 495 644 3240

Turkey: Delta Greentech Elektronik San. Ltd. Sti. (Turkey)
Şerifali Mah. Hendem Cad. Kule Sok. No:16-A
34775 Ümraniye – İstanbul
Mail: Sales.IA.Turkey@deltaww.com
TEL: + 90 216 499 9910

GCC: Delta Energy Systems AG (Dubai BR)
P.O. Box 185668, Gate 7, 3rd Floor, Hamarain Centre
Dubai, United Arab Emirates
Mail: Sales.IA.MEA@deltaww.com
TEL: +971(0)4 2690148

Egypt + North Africa: Delta Electronics
511 Cairo Business Plaza, North 90 street,
New Cairo, Cairo, Egypt
Mail: Sales.IA.MEA@deltaww.com

Delta Compact Drive MS300 IP66 / NEMA 4X Series User Manual



Delta Compact Drive MS300 IP66 / NEMA 4X Series User Manual

Copyright notice

©Delta Electronics, Inc. All rights reserved.

All information contained in this user manual is the exclusive property of Delta Electronics Inc.

(hereinafter referred to as "Delta ") and is protected by copyright law and all other laws. Delta retains the exclusive rights of this user manual in accordance with the copyright law and all other laws. No parts in this manual may be reproduced, transmitted, transcribed, translated or used in any other ways without the prior consent of Delta.

Limitation of Liability

The contents of this user manual are only for the use of the AC motor drives manufactured by Delta. Except as defined in special mandatory laws, Delta provides this user manual "as is" and does not offer any kind of warranty through this user manual for using the product, either express or implied, including but not limited to the following: (i) this product will meet your needs or expectations; (ii) the information contained in the product is current and correct; (iii) the product does not infringe any rights of any other person. You shall bear your own risk to use this product.

In no event shall Delta, its subsidiaries, affiliates, managers, employees, agents, partners and licensors be liable for any direct, indirect, incidental, special, derivative or consequential damages (including but not limited to the damages for loss of profits, goodwill, use or other intangible losses) unless the laws contains special mandatory provisions to the contrary.

Delta reserves the right to make changes to the user manual and the products described in the user manual without prior notice and afterwards.

PLEASE READ PRIOR TO INSTALLATION FOR SAFETY.



- ☑ Disconnect AC input power before connecting any wiring to the AC motor drive.
- ☑ There are highly sensitive MOS components on the printed circuit boards. These components are especially sensitive to static electricity. Take anti-static measures before touching these components or the circuit boards.
- ☑ Never modify the internal components or wiring.
- ☑ Ground the AC motor drive by using the ground terminal. The grounding method must comply with the laws of the country where the AC motor drive is to be installed.
- ☑ DO NOT install the AC motor drive in a location with high temperature, direct sunlight or inflammable materials or gases.



- ☑ Never connect the AC motor drive output terminals U/T1, V/T2 and W/T3 directly to the AC mains circuit power supply.
- ☑ After finishing the wiring of the AC motor drive, check if U/T1, V/T2, and W/T3 are short-circuited to ground with a multimeter. Do NOT power the drive if short circuits occur. Eliminate the short circuits before the drive is powered.
- ☑ The rated voltage of power system to install motor drives is listed below. Ensure that the installation voltage is in the correct range when installing a motor drive.
For 230V models, the range is between 170–264 V.
For 460V models, the range is between 323–528 V.
- ☑ See the table below for the short-circuit current capacity

Model Series (Power)	Short-circuit Current Capacity
230V / 460V	100 kA

- ☑ Only qualified persons are allowed to install, wire and maintain the AC motor drives.
- ☑ Even if the three-phase AC motor is stopped, a charge with hazardous voltages may still remain in the main circuit terminals of the AC motor drive.
- ☑ The performance of electrolytic capacitor will degrade if it is not charged for a long time. It is recommended to charge the drive which is stored in no charge condition every 2 years for 3~4 hours to restore the performance of electrolytic capacitor in the motor drive. Note: When power up the motor drive, use adjustable AC power source (ex. AC autotransformer) to charge the drive at 70%~80% of rated voltage for 30 minutes (do not run the motor drive). Then charge the drive at 100% of rated voltage for an hour (do not run the motor drive). By doing these, restore the performance of electrolytic capacitor before starting to run the motor drive. Do NOT run the motor drive at 100% rated voltage right away.
- ☑ Pay attention to the following precautions when transporting and installing this package (including wooden crate and wood stave).
 - 1 If you need to deworm the wooden crate, do not use fumigation or you will damage the drive. Any damage to the drive caused by using fumigation voids the warranty.
 - 2 Use other methods, such as heat treatment or any other non-fumigation treatment, to deworm the wood packaging material.

3 If you use heat treatment to deworm, leave the packaging materials in an environment of over 56°C for a minimum of thirty minutes.

- ☑ Connect the drive to a three-phase three-wire or three-phase four-wire Wye system to comply with UL standards.
- ☑ If the drive generates leakage current over AC 3.5 mA or DC 10 mA on a grounding conductor, compliance with local grounding regulations or IEC61800-5-1 standard is the minimum requirement for grounding.

 **NOTE**

- In the pictures in this manual, the cover or safety shield is disassembled only when explaining the details of the product. During operation, install the top cover and wiring correctly according to the provisions. Refer to the operation descriptions in the manual to ensure safety.
- The figures in this instruction are only for reference and may be slightly different depending on your model, but it will not affect your customer rights.
- The content of this manual may be revised without prior notice. Consult our distributors or download the latest version at http://www.deltaww.com/iadownload_acmotordrive

Table of Contents

CHAPTER 1 INTRODUCTION.....	1-1
1-1 Nameplate Information.....	1-2
1-2 Model Name.....	1-3
1-3 Serial Number.....	1-3
1-4 RFI Jumper.....	1-4
CHAPTER 2 DIMENSION.....	2-1
2-1 Frame A.....	2-2
2-2 Frame B.....	2-3
2-3 Frame C.....	2-4
2-4 Dimensions and Models for Plastic Cable Glands.....	2-5
CHAPTER 3 INSTALLATION	3-1
3-1 Minimum Mounting Clearance and Installation.....	3-2
3-2 Airflow Rate for Cooling and Power Dissipation.....	3-3
CHAPTER 4 WIRING.....	4-1
4-1 System Wiring Diagram.....	4-3
4-2 Wiring.....	4-4
CHAPTER 5 MAIN CIRCUIT TERMINALS	5-1
5-1 Main Circuit Diagram.....	5-4
5-2 Main Circuit Terminals.....	5-5
CHAPTER 6 CONTROL TERMINALS	6-1
6-1 Control Circuit Terminals Specifications	6-2
CHAPTER 7 OPTIONAL ACCESSORIES.....	7-1
7-1 All Brake Resistors and Brake Units Used in AC Motor Drives.....	7-2
7-2 Non-fuse Circuit Breaker.....	7-4
7-3 Fuse Specification Chart	7-5
7-4 AC/DC Reactor.....	7-7
7-5 Zero Phase Reactors.....	7-17
7-6 EMC Filter.....	7-20
7-7 EMC Shield Plate.....	7-23
7-8 Capacitive Filter.....	7-30
7-9 Fan Kit.....	7-31
7-10 Main Switch.....	7-46

CHAPTER 8 OPTION CARDS	8-1
8-1 Option Card Installation.....	8-2
8-2 CMM-MOD01 -- Communication Extension Card, Modbus TCP.....	8-7
8-3 CMM-PD01 -- Communication Extension Card, PROFIBUS DP.....	8-10
8-4 CMM-DN01 -- Communication Extension Card, DeviceNet.....	8-12
8-5 CMM-EIP01 -- Communication Extension Card, EtherNet/IP.....	8-15
8-6 CMM-COP01 -- Communication Extension Card, CANopen.....	8-18
8-7 EMM-BPS01 -- +24 V Power Extension Card.....	8-19
8-8 Delta Bus Standard Wire.....	8-20
 CHAPTER 9 SPECIFICATIONS.....	 9-1
9-1 230V Series.....	9-2
9-2 460V Series.....	9-4
9-3 Environment for Operation, Storage and Transportation.....	9-6
9-4 Derating for Ambient Temperature and Altitude.....	9-7
 CHAPTER 10 DIGITAL KEYPAD.....	 10-1
 CHAPTER 11 SUMMARY OF PARAMETERS SETTINGS.....	 11-1
 CHAPTER 12 DESCRIPTION OF PARAMETER SETTINGS.....	 12-1
 CHAPTER 13 WARNING CODES	 13-1
 CHAPTER 14 ERROR CODES.....	 14-1
 CHAPTER 15 CANOPEN OVERVIEW	 15-1
 CHAPTER 16 PLC FUNCTION APPLICATIONS.....	 16-1
 CHAPTER 17 SAFE TORQUE OFF FUNCTION.....	 17-1

Issued Edition: 01

Firmware Version: V1.08 (Refer to Parameter 00-06 on the product to get the firmware version.)

Issued Date: 2019/1

Chapter 1 Introduction

1-1 Nameplate Information

1-2 Model Name

1-3 Serial Number

1-4 RFI Jumper

After receiving the AC motor drive, check for the following:

1. Inspect the unit after unpacking to ensure that it was not damaged during shipment. Make sure that the part number printed on the package matches the part number indicated on the nameplate.
2. Make sure that the mains voltage is within the range indicated on the nameplate. Install the AC motor drive according to the instructions in this manual.
3. Before applying power, make sure that all devices, including mains power, motor, control board and digital keypad, are connected correctly.
4. When wiring the AC motor drive, make sure that the wiring for input terminals “R/L1, S/L2, T/L3”, and output terminals “U/T1, V/T2, W/T3” are correct to prevent damage to the drive.
5. When power is applied, use the digital keypad to select the language and set parameters. When executing a trial run, begin with a low speed and then gradually increase the speed to the desired speed.

1-1 Nameplate Information

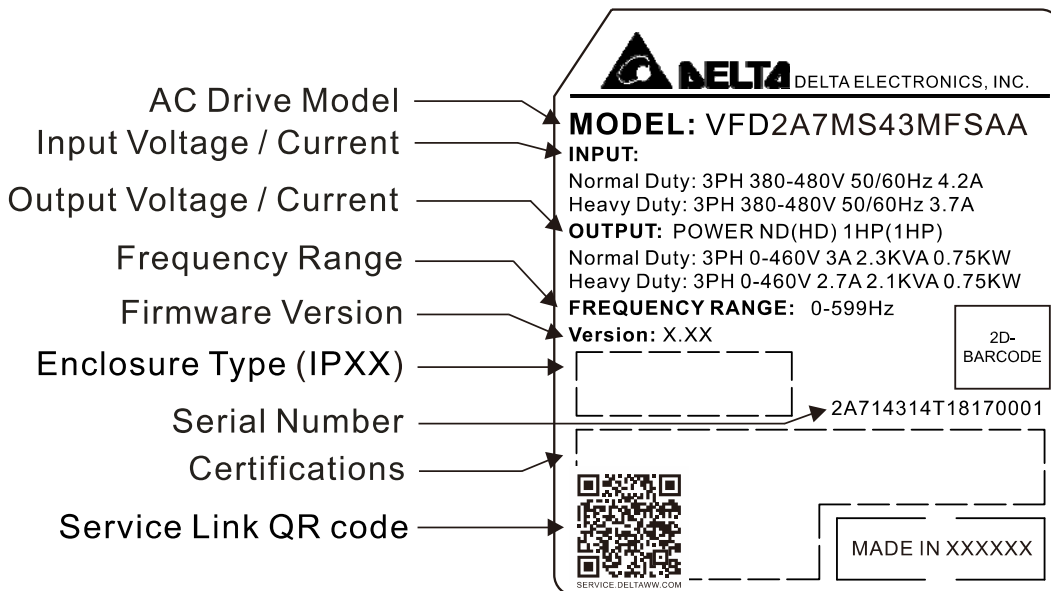

Figure 1-1

NOTE

Service Link QR Code

Scan QR Code to apply for service

1. Locate the QR code sticker (as shown in Figure 1-1).
2. Use a smartphone to run a QR Code reader App.
3. Point your camera at the QR Code. Hold your camera steady so that the QR code comes into focus.
4. Access the Delta After Service website.
5. Enter your information in the column marked with an orange star.
6. Enter the CAPTCHA and click **Submit** to complete the application.

Cannot find out the QR Code?

1. Open a web browser on your computer or smartphone.
2. In the browser address bar, enter <https://service.deltaww.com/ia/repair> and press **Enter**.
3. Enter your information in the columns marked with an orange star.
4. Enter the CAPTCHA and click **Submit** to complete the application.

1-2 Model Name

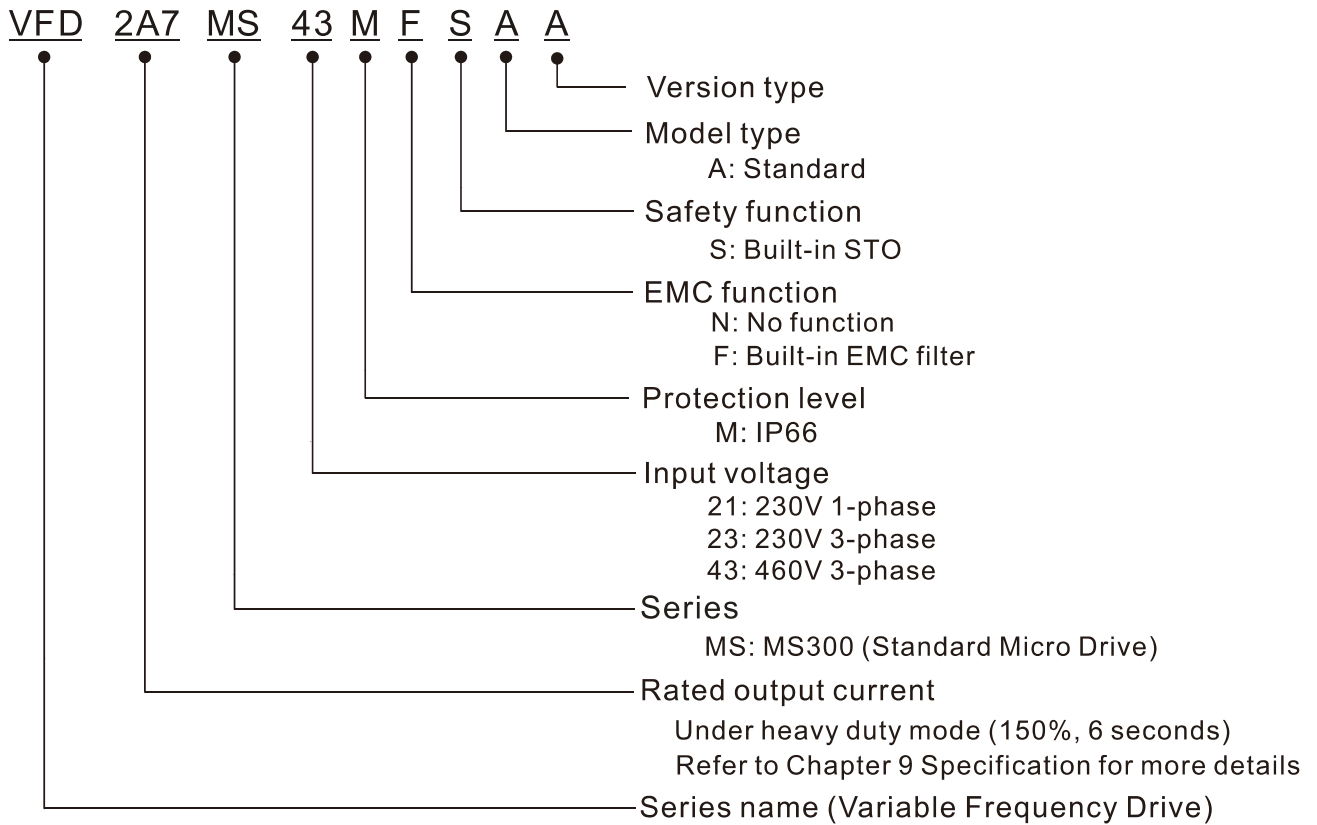

1-3 Serial Number

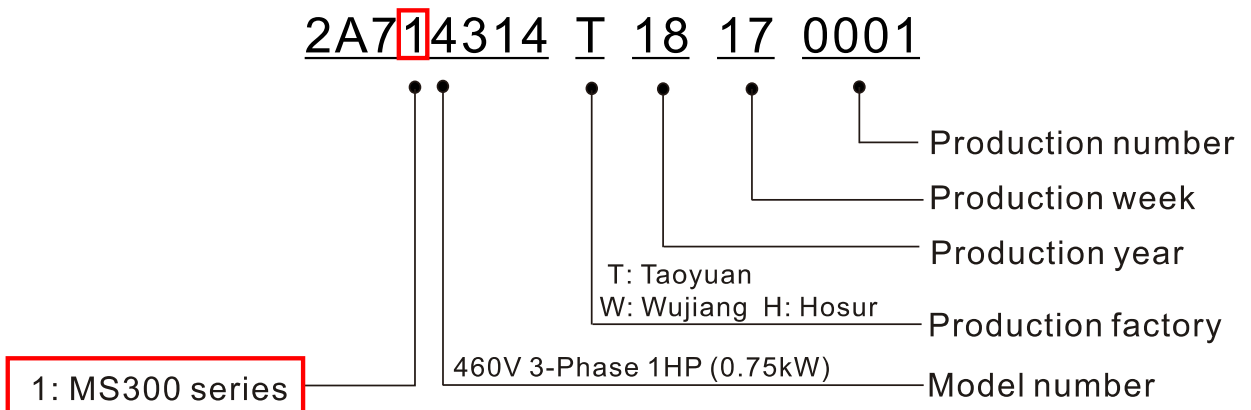

1-4 RFI Jumper

The drive contains Varistors/MOVs that are connected from phase to phase and from phase to ground to protect the drive against mains surges or voltage spikes.

Because the Varistors/MOVs from phase to ground are connected to ground with the RFI jumper, removing the RFI jumper disables the protection.

- (1) In models with a built-in EMC filter, the RFI jumper connects the filter capacitors to ground to form a return path for high frequency noise. This isolates the noise from contaminating the mains power. Removing the RFI jumper strongly reduces the effect of the built-in EMC filter.
- (2) Although a single drive complies with the international standards for leakage current, an installation with several drives with built-in EMC filters can trigger the RCD. Removing the RFI jumper can help, but the EMC performance of each drive is no longer guaranteed.
- (3) Description for removing and connecting the RFI jumper.

Frame A-C (model without built-in EMC filter) Screw Torque: 4–6 kg-cm / [3.5-5.2 lb-in.] / [0.39-0.59 Nm]

Loosen the screw (as shown in Figure 1-2) and turn the RFI jumper counterclockwise (as shown in Figure 1-3) to remove. Fasten the screw again after you remove the RFI jumper. To connect the RFI jumper, loosen the screw and turn clockwise (the position of RFI jumper changes from Figure 1-3 to Figure 1-2). Similarly, fasten the screw again after you connect the RFI jumper.

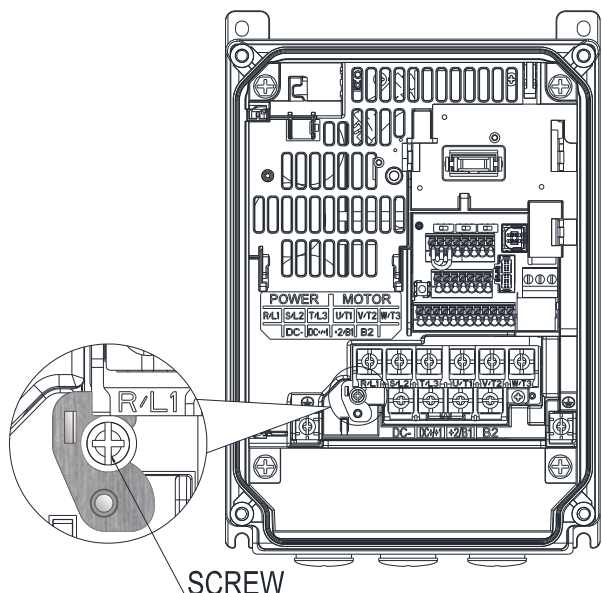

Figure 1-2

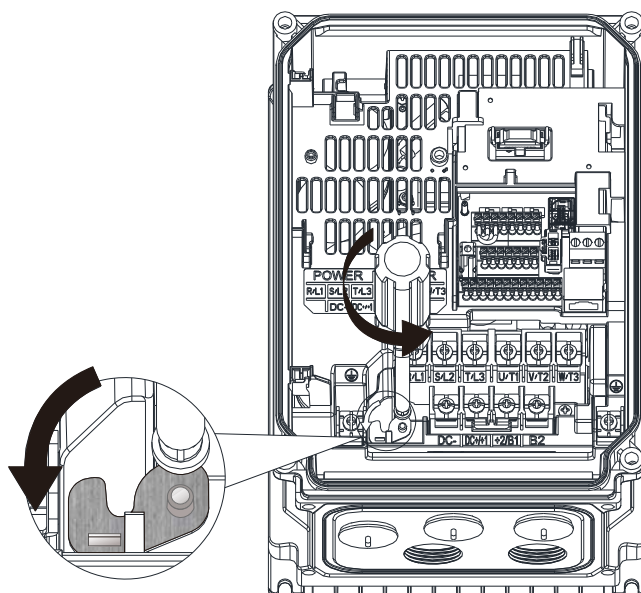

Figure 1-3

Frame A (model with built-in EMC filter)

Lift up with a slotted screwdriver to remove the RFI jumper (as shown in Figure 1-4) and push down (as shown in Figure 1-5) to connect the RFI jumper.

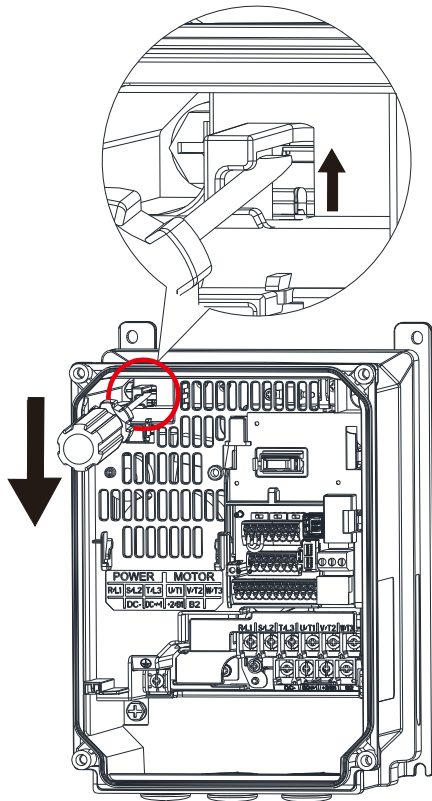

Figure 1-4

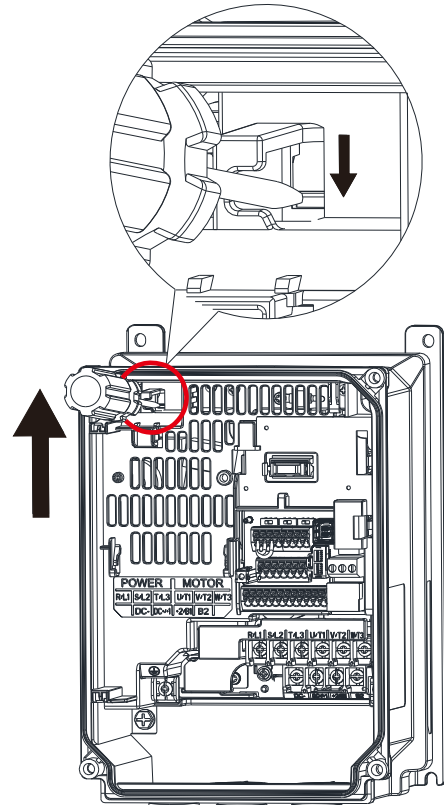

Figure 1-5

Frame B-C (model with built-in EMC filter)

● **Removing the RFI Jumper**

After removing the RFI jumper, clip it to the supplementary rib for future use.

1. Lift up the RFI jumper with a slotted screwdriver.

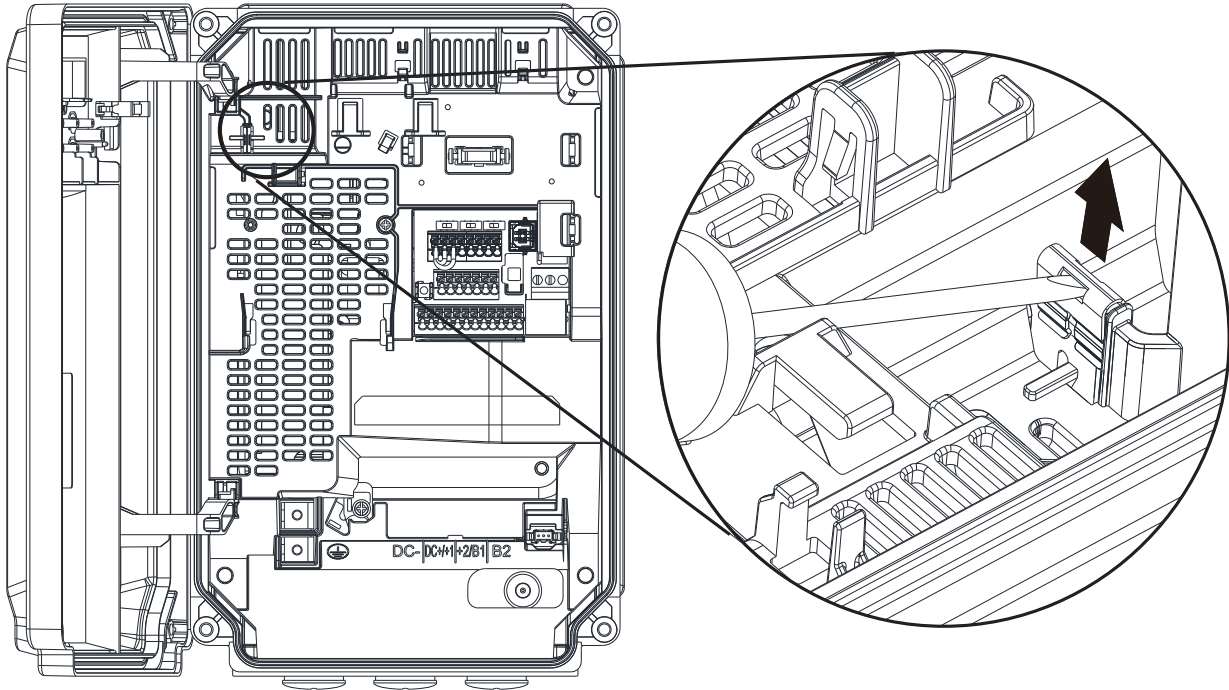

Figure 1-6

2. Remove the RFI jumper.

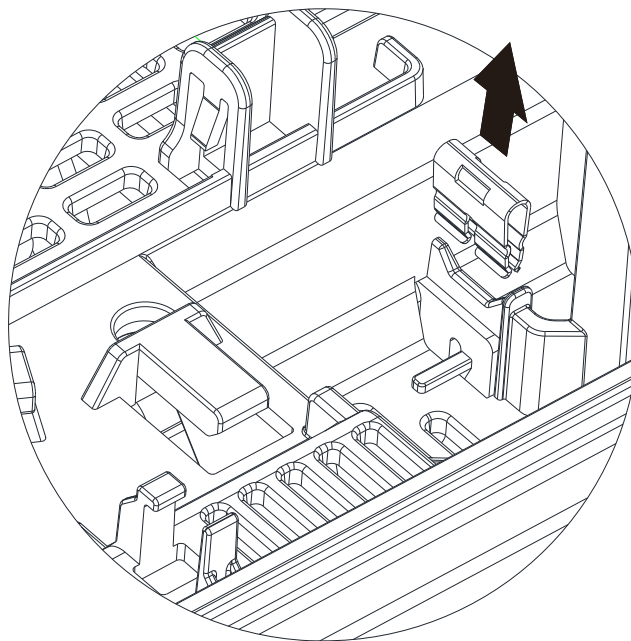

Figure 1-7

3. Clip the RFI jumper to the upper supplementary rib.

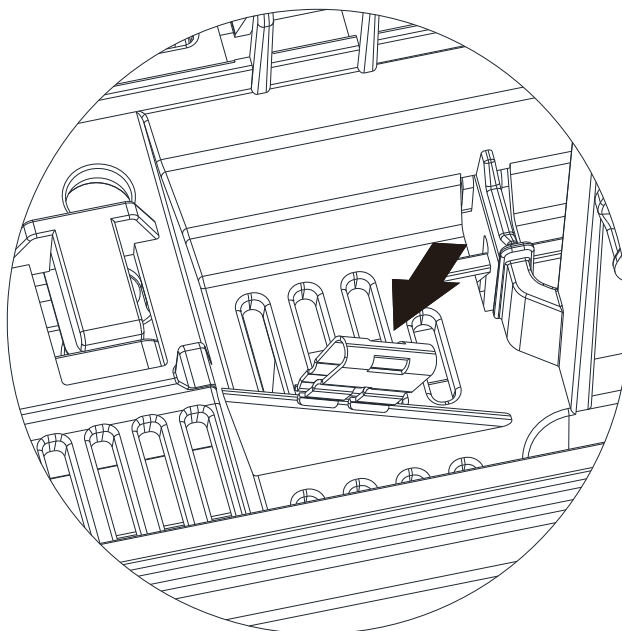

Figure 1-8

4. Press the RFI jumper to fix it on the upper supplementary rib.

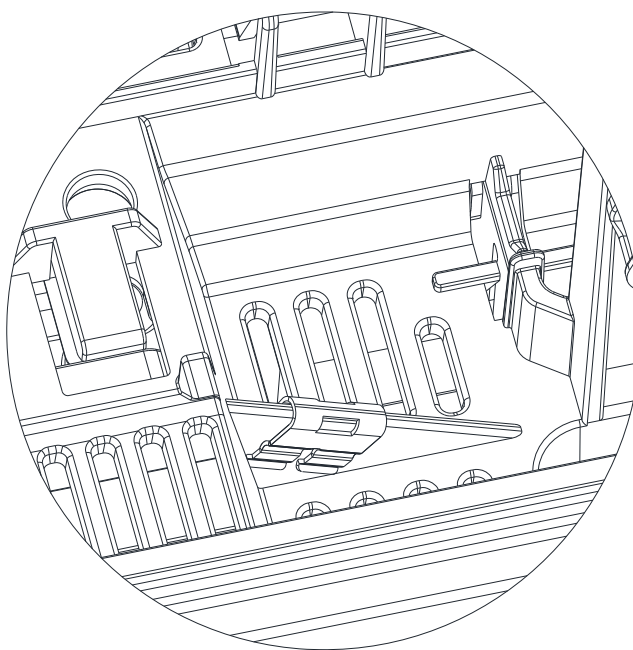

Figure 1-9

● **Connecting the RFI Jumper**

Press the RFI jumper to fix it.

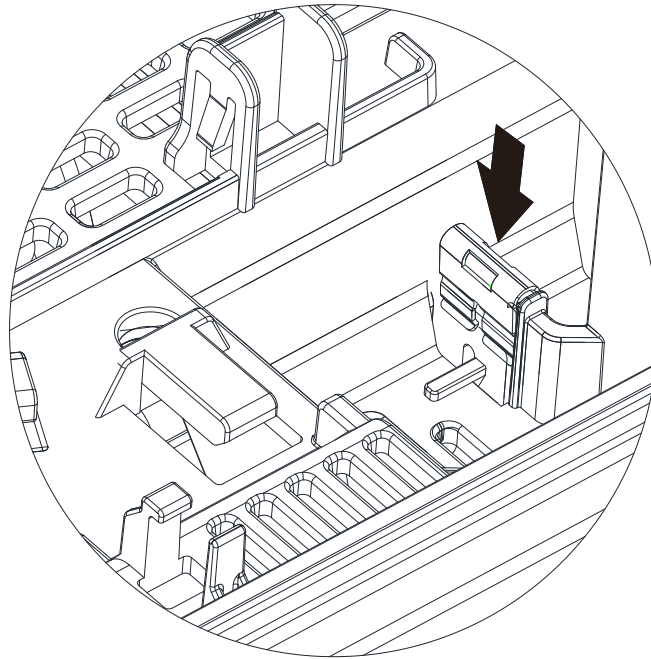

Figure 1-10

 **NOTE**

Make sure that the RFI jumper is fixed on the correct position when connecting the RFI jumper.

Correct fixing

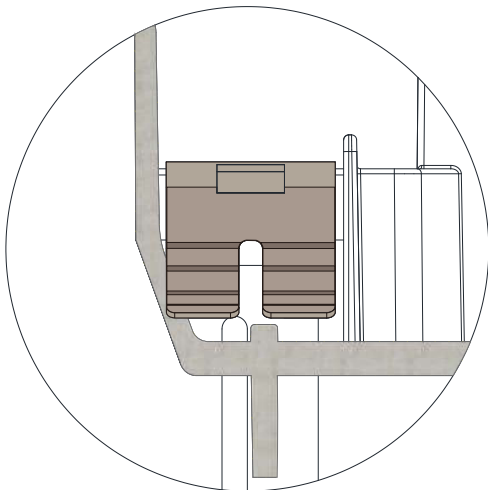

Figure 1-11

Wrong fixing

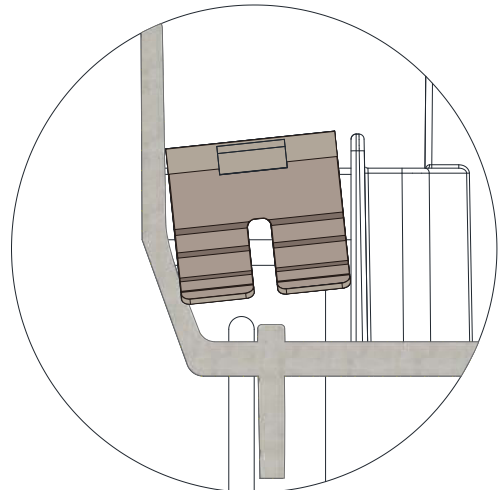

Figure 1-12

Isolating main power from ground:

When the power distribution system for the drive is a floating ground system (IT Systems) or an asymmetric ground system (Corner Grounded TN Systems), you must remove the RFI jumper. Removing the RFI jumper disconnects the internal capacitors from ground to avoid damaging the internal circuits and to reduce the ground leakage current.

Important points regarding ground connection:

- ☑ To ensure the safety of personnel, proper operation, and to reduce electromagnetic radiation, you must properly ground the drive during installation.
- ☑ The diameter of the cables must comply with the local safety regulations.
- ☑ The shields of shielded cables must be connected to the ground of the drive to meet safety regulations.
- ☑ The shields of shielded power cables can only be used as the ground for equipment when the above points are met.
- ☑ When installing more drives, do not connect the grounds of the drives in series but connect each drive to ground. The following pictures (Figure 1-13 and Figure 1-14) show the correct and wrong ways to connect the grounds.

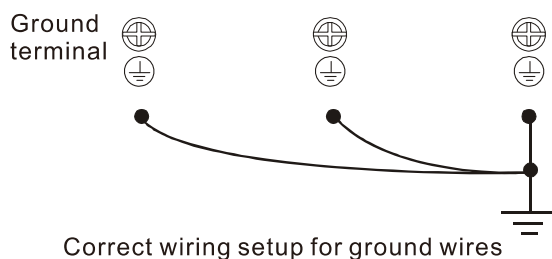

Figure 1-13

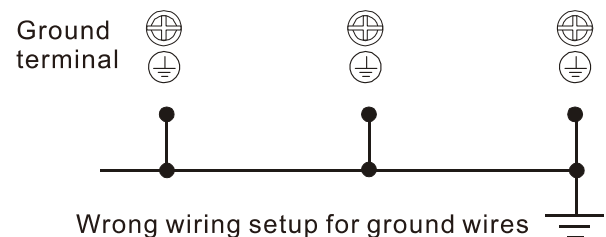

Figure 1-14

Pay particular attention to the following points:

- ☑ Do not remove the RFI jumper while the power is on.
- ☑ Removing the RFI jumper also disconnects the built-in EMC filter capacitors. Compliance with the EMC specifications is no longer guaranteed.
- ☑ Do not remove the RFI jumper if the mains power is a symmetrical grounded power system in order to maintain the efficiency for EMC circuit.
- ☑ Do not remove the RFI jumper while conducting high voltage tests. When conducting a high voltage test to the entire facility, you must disconnect the mains power and the motor if the leakage current is too high.

Floating Ground System (IT Systems)

A floating ground system is also called an IT system, an ungrounded system, or a high impedance/resistance (greater than 30 Ω) grounded system.

- ☑ Remove the RFI jumper to cut off the connection between the grounded internal filter capacitor and the surge absorber to the ground.
- ☑ Check whether there is excess electromagnetic radiation affecting nearby low-voltage circuits.
- ☑ In some situations, the transformer and cable naturally provide enough EM radiation suppression. If in doubt, install an extra electrostatic shielded cable on the power supply side between the main circuit and the control terminals to increase security.

- ☑ Do not install an external EMC filter. The EMC filter is connected to ground through the filter capacitors, and connects the power input to ground. This is very dangerous and can easily damage the drive.

Asymmetric Ground System (Corner Grounded TN Systems)

Caution: Do not remove the RFI jumper while there is power to the input terminal of the drive.

In the following four situations, you must remove the RFI jumper. This is to prevent the system from grounding through the RFI and filter capacitors and damaging the drive.

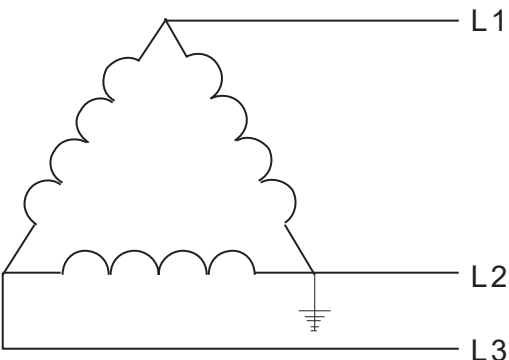
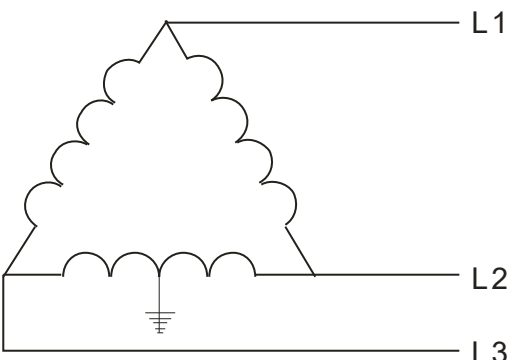
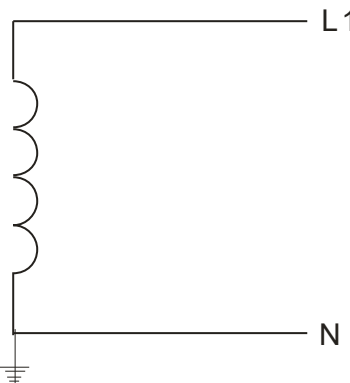
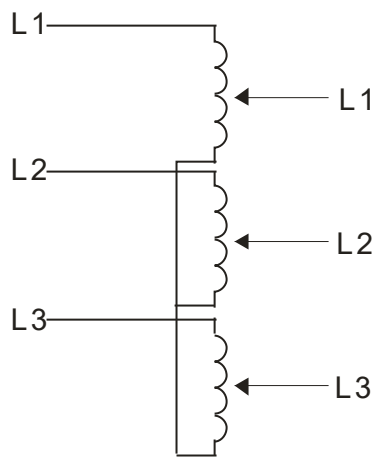
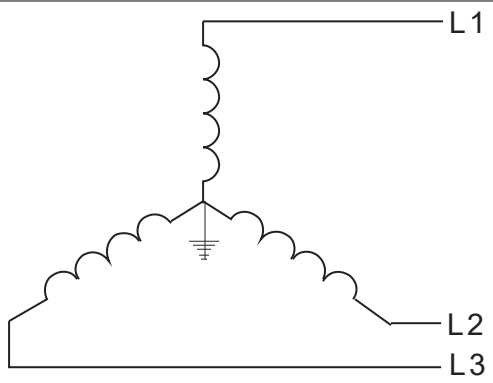
You must remove the RFI jumper	
<p>1. Grounding at a corner in a triangle configuration</p>  <p style="text-align: center;">Figure 1-15</p>	<p>2. Grounding at a midpoint in a polygonal configuration</p>  <p style="text-align: center;">Figure 1-16</p>
<p>3. Grounding at one end in a single-phase configuration</p>  <p style="text-align: center;">Figure 1-17</p>	<p>4. No stable neutral grounding in a three-phase autotransformer configuration</p>  <p style="text-align: center;">Figure 1-18</p>
You can use the RFI jumper	
<p>Internal grounding through RFI capacitors that reduce electromagnetic radiation. In a symmetrically grounding power system with higher EMC requirements, install an EMC filter. As a reference, Figure 1-19 is a symmetrical grounding power system.</p>	
 <p style="text-align: center;">Figure 1-19</p>	

[This page intentionally left blank]

Chapter 2 Dimensions

2-1 Frame A

2-2 Frame B

2-3 Frame C

2-4 Dimensions and Models for Plastic Cable Glands

2-1 Frame A

A1: VFD2A8MS21MNSAA; VFD2A8MS21MFSAA; VFD2A8MS23MNSAA; VFD1A5MS43MNSAA;
 VFD1A5MS43MFSAA; VFD4A8MS21MNSAA; VFD4A8MS21MFSAA; VFD4A8MS23MNSAA;
 VFD2A7MS43MNSAA; VFD2A7MS43MFSAA

A2: VFD7A5MS21MNSAA; VFD7A5MS23MNSAA; VFD4A2MS43MNSAA; VFD4A2MS43MFSAA

A3: VFD5A5MS43MNSAA

Unit: mm [inch]

Frame	W	H	D	W1	H1	D1	S1
A1	160.0 [6.30]	230.0 [9.06]	151.0 [5.94]	146.0 [5.75]	216.5 [8.52]	4.0 [0.16]	5.5 [0.22]
A2	160.0 [6.30]	230.0 [9.06]	167.0 [6.57]	146.0 [5.75]	216.5 [8.52]	4.0 [0.16]	5.5 [0.22]
A3	160.0 [6.30]	230.0 [9.06]	190.0 [7.48]	146.0 [5.75]	216.5 [8.52]	4.0 [0.16]	5.5 [0.22]

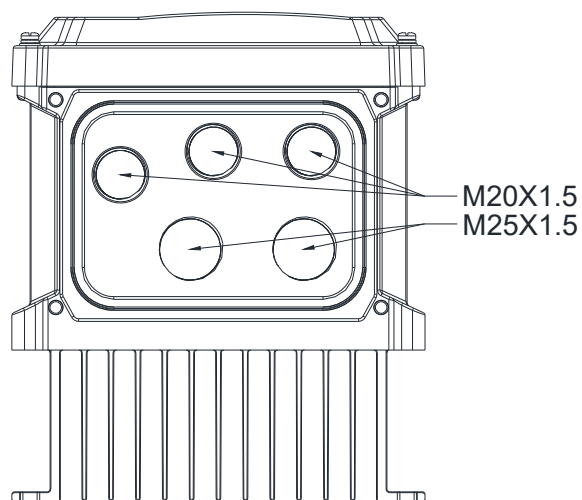
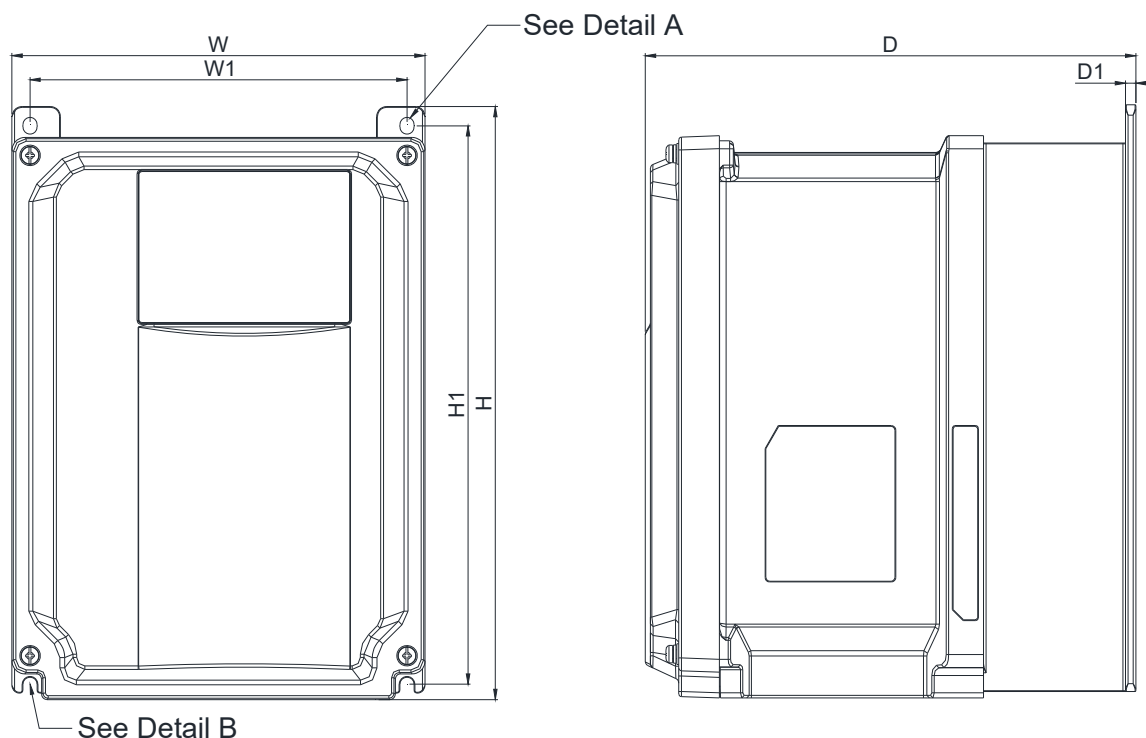

Detail A (Mounting Hole)



Detail B (Mounting Hole)

2-2 Frame B

VFD7A5MS21MFSAA; VFD11AMS21MNSAA; VFD11AMS21MFSAA; VFD11AMS23MNSAA;
 VFD5A5MS43MFSAA; VFD17AMS23MNSAA; VFD9A0MS43MNSAA; VFD9A0MS43MFSAA

Unit: mm [inch]

Frame	W	H	D	W1	H1	D1	S1
B	175.0 [6.89]	280.0 [11.02]	193.0 [7.60]	152.0 [5.98]	266.0 [10.43]	10 [0.39]	6.4 [0.25]

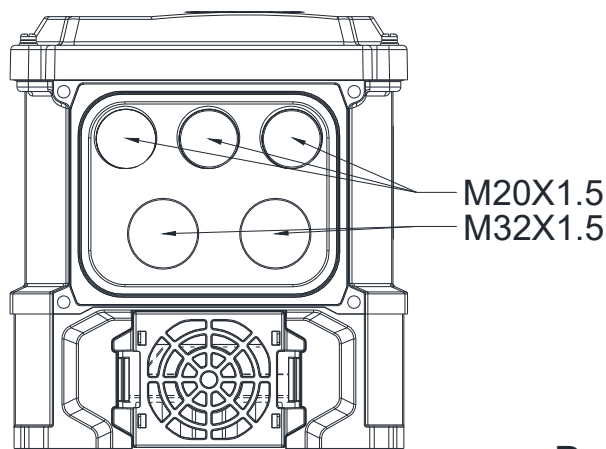
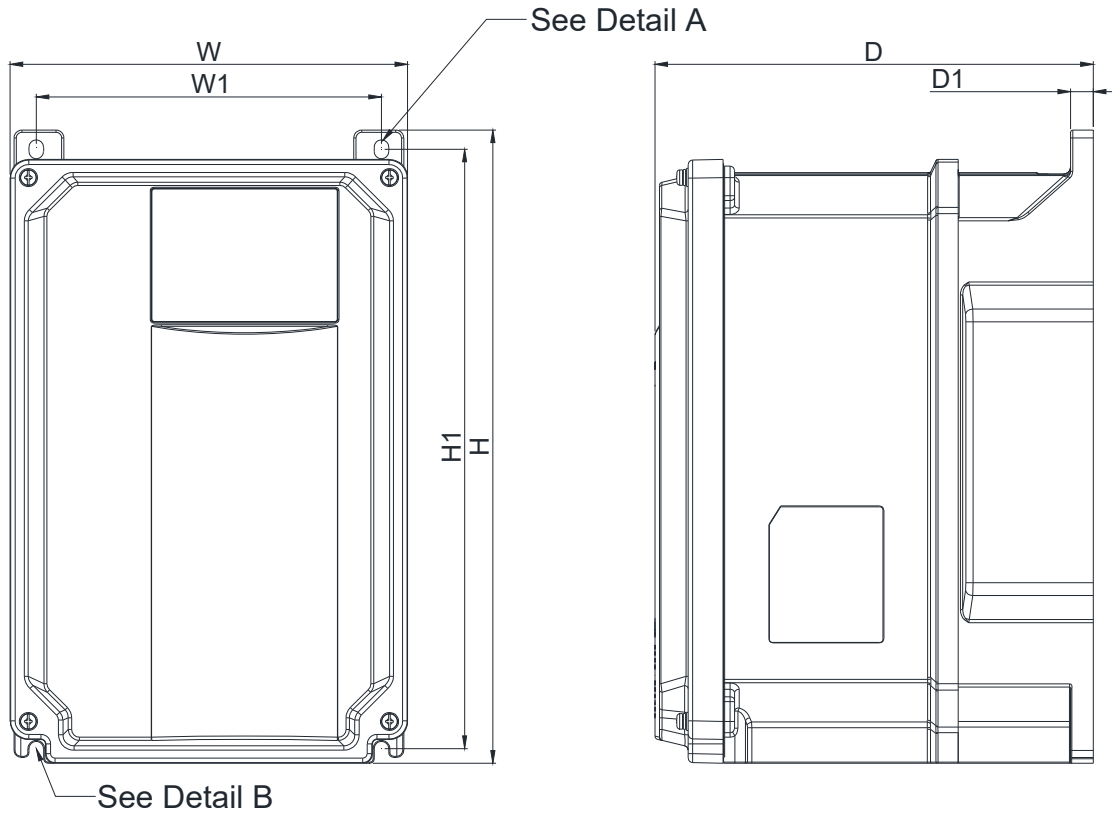

Detail A (Mounting Hole)

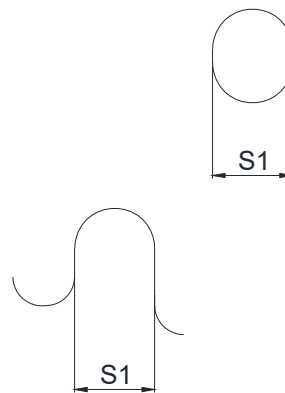

Detail B (Mounting Hole)

2-3 Frame C

VFD13AMS43MNSAA; VFD13AMS43MFSAA; VFD25AMS23MNSAA; VFD17AMS43MNSAA;
VFD17AMS43MFSAA

Unit: mm [inch]

Frame	W	H	D	W1	H1	D1	S1
C	195.0 [7.68]	300.0 [11.81]	193.0 [7.606]	172.4 [6.79]	285.0 [11.22]	10 [0.39]	6.4 [0.25]

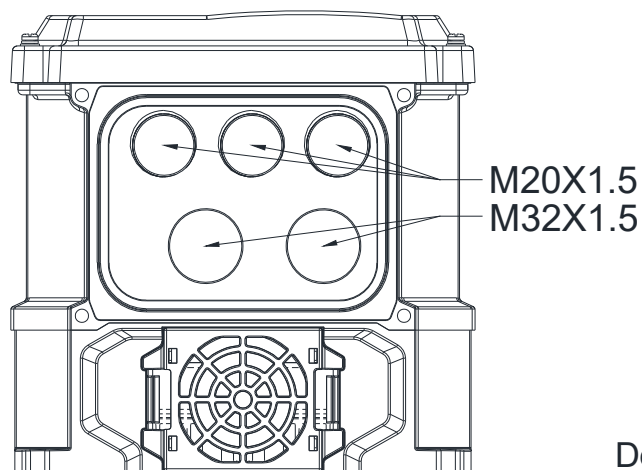
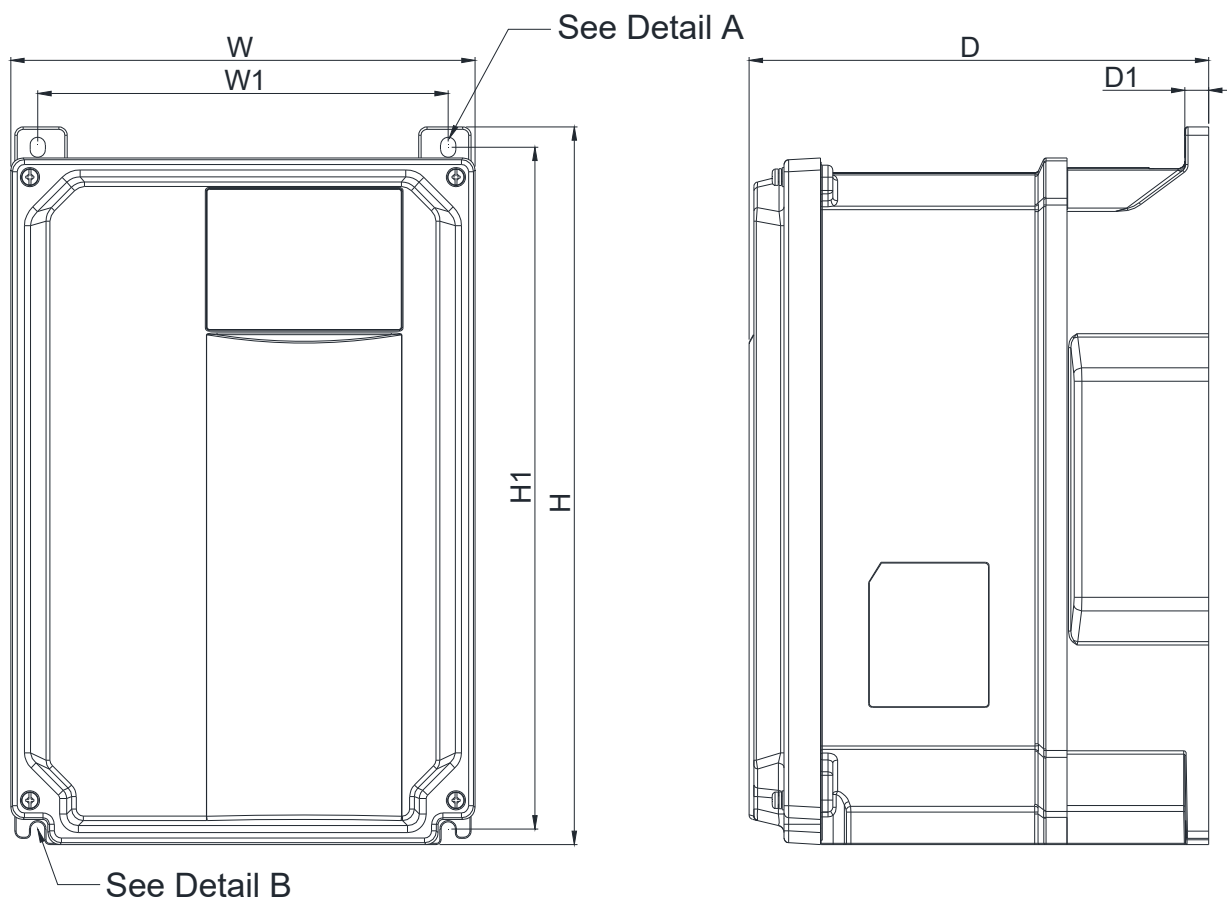

Detail A (Mounting Hole)

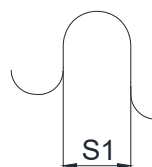

Detail B (Mounting Hole)

2-4 Dimensions and Models for Plastic Cable Glands

Unit: mm [inch]

Frame	Function	Screw	D Max.	ΦA MAX.	Suggested AVC Category No.* or Equivalent
A	Control Wiring Hole	M20 P1.5	11 [0.43]	31 [1.22]	MG20A-XX
	Main Circuit Wiring Hole	M25 P1.5	11 [0.43]	37 [1.46]	MG25A-XX
B	Control Wiring Hole	M20 P1.5	11 [0.43]	31 [1.22]	MG20A-XX
	Main Circuit Wiring Hole	M32 P1.5	11 [0.43]	47 [1.85]	MG32A-XX
C	Control Wiring Hole	M20 P1.5	11 [0.43]	31 [1.22]	MG20A-XX
	Main Circuit Wiring Hole	M32 P1.5	11 [0.43]	47 [1.85]	MG32A-XX

* -XX means that you select the appropriate AVC Category No. according to the cable outside diameter you use.

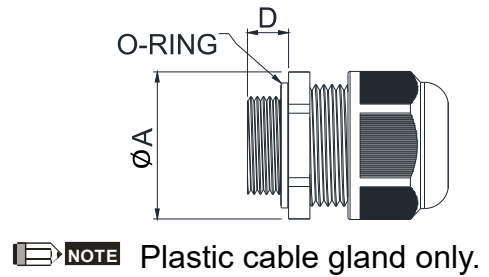
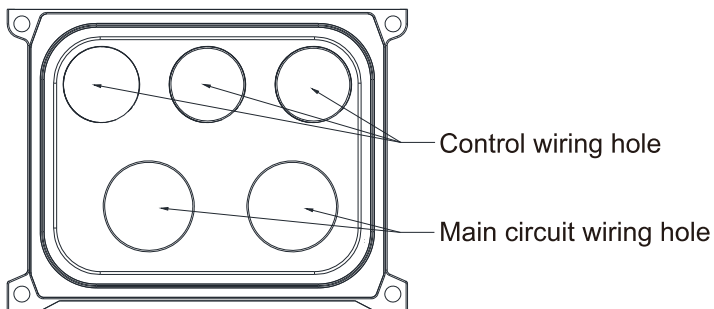

[This page intentionally left blank]

Chapter 3 Installation

3-1 Minimum Mounting Clearance and Installation

3-2 Airflow Rate for Cooling and Power Dissipation

3-1 Minimum Mounting Clearance and Installation

- ☑ Prevent fiber particles, scraps of paper, shredded wood sawdust, metal particles, etc. from adhering to the heat sink.
- ☑ Install the AC motor drive in a metal cabinet. When installing one drive below another one, use a metal separator between the AC motor drives to prevent mutual heating and to prevent the risk of accidental fire.
- ☑ Install the AC motor drive in Pollution Degree 2 environments only: normally only non-conductive pollution occurs and temporary conductivity caused by condensation is expected.
- ☑ Mount the drive in an IP66 or NEMA 4X cabinet in order to maintain the Pollution Degree 2 or in a pollution-controlled environment.

The following figure is for reference only.

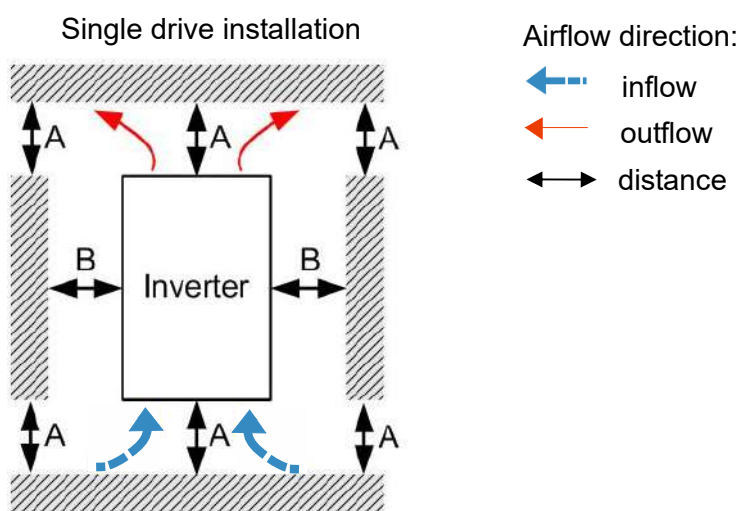

Minimum mounting clearance

Installation method	A (mm)	B (mm)	Ambient temperature (°C)	
			Max. (Without derating)	Max. (derating)
Single drive installation	50	30	40	50

 **NOTE**

The minimum mounting clearances A and B stated in the table above apply to AC motor drives installation. Failing to follow the minimum mounting clearances may cause the fan to malfunction and cause heat dissipation problems.

3-2 Airflow Rate for Cooling and Power Dissipation

Frame	Airflow Rate for Cooling			Power Dissipation		
	Model No.	Flow Rate (Unit: cfm)	Flow Rate (Unit: m ³ / hr)	Loss External (Heat sink, unit: W)	Internal (Unit: W)	Total (Unit: W)
A	VFD1A5MS43MFSAA	0.0	0.0	17.6	11.1	28.7
	VFD1A5MS43MNSAA					
	VFD2A7MS43MFSAA			30.5	17.8	48.3
	VFD2A7MS43MNSAA					
	VFD2A8MS21MFSAA			16.3	14.5	30.8
	VFD2A8MS21MNSAA					
	VFD2A8MS23MNSAA			16.5	12.6	29.1
	VFD4A2MS43MFSAA			45.9	21.7	67.6
	VFD4A2MS43MNSAA					
	VFD4A8MS21MFSAA			29.1	20.1	49.2
	VFD4A8MS21MNSAA					
	VFD4A8MS23MNSAA			31.0	13.2	44.2
	VFD5A5MS43MNSAA			60.6	22.8	83.4
	VFD7A5MS21MNSAA			46.5	31	77.5
VFD7A5MS23MNSAA	50.1	24.2	74.3			
B	VFD5A5MS43MFSAA	27.3	46.4	60.6	22.8	83.4
	VFD7A5MS21MFSAA			46.5	31.0	77.5
	VFD9A0MS43MFSAA			93.1	42.0	135.1
	VFD9A0MS43MNSAA					
	VFD11AMS21MFSAA			70.0	35.0	105.0
	VFD11AMS21MNSAA					
	VFD11AMS23MNSAA			76.0	30.7	106.7
	VFD17AMS23MNSAA			108.2	40.1	148.3
C	VFD13AMS43MFSAA	33.5	56.6	132.8	39.5	172.3
	VFD13AMS43MNSAA					
	VFD17AMS43MFSAA			164.7	55.8	220.5
	VFD17AMS43MNSAA					
	VFD25AMS23MNSAA			192.8	53.3	246.1



[This page intentionally left blank]

Chapter 4 Wiring

4-1 System Wiring Diagram

4-2 Wiring

After removing the front cover, verify that the power and control terminals are clearly visible. Read the following precautions to avoid wiring mistakes.

	<ul style="list-style-type: none">☑ It is crucial to cut off the AC motor drive power before doing any wiring. A charge with hazardous voltages may still remain in the DC BUS capacitors even after the power has been turned off for a short time. Measure the remaining voltage with a DC voltmeter on +1/DC+ and DC- before doing any wiring. For your safety, do not start wiring before the voltage drops to a safe level (less than 25 V_{DC}). Installing wiring with a residual voltage may cause injuries, sparks and short circuits.☑ Only qualified personnel familiar with AC motor drives are allowed to perform installation, wiring and commissioning. Make sure the power is turned off before wiring to prevent electric shocks.☑ The terminals R/L1, S/L2, and T/L3 are for mains power input. If mains power is incorrectly connected to other terminals, it may result in damage to the equipment. The voltage and current must be in the range indicated on the nameplate (see Section 1-1).☑ All units must be grounded directly to a common ground terminal to prevent electrical shocks or damage from lightning.☑ Tighten the screw of the main circuit terminals to prevent sparks due to loosening of the terminals resulted from vibration.
	<ul style="list-style-type: none">☑ When wiring, choose wires that comply with local regulations for your safety.☑ Check the following items after you finish the wiring:<ol style="list-style-type: none">1. Are all connections correct?2. Are there any loose wires?3. Are there any short circuits between the terminals or to ground?

4-1 System Wiring Diagram

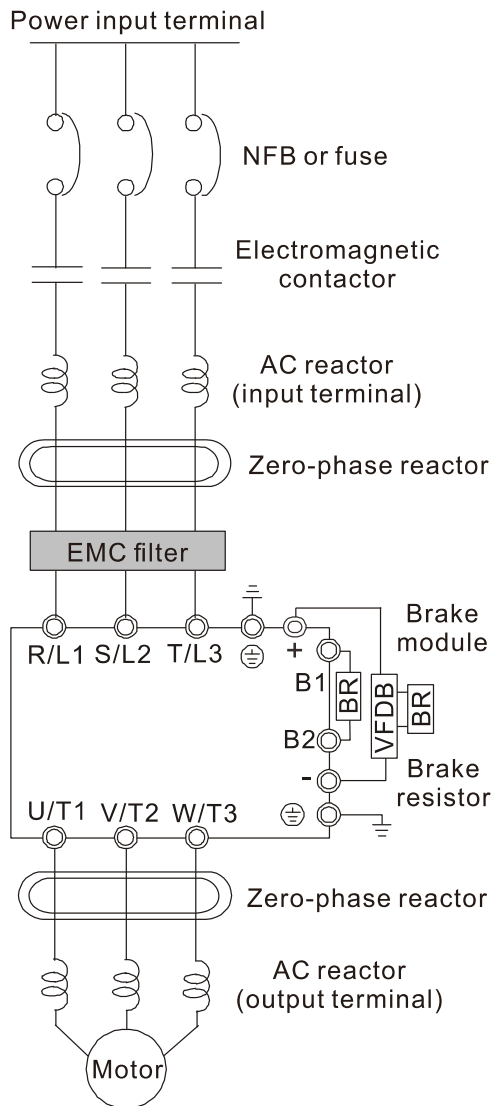

Figure 4-1

Power input terminal	Please refer to Chapter 9 Specification Table in the user manual for details.
NFB or fuse	There may be a large inrush current during power on. Refer to Section 7-2 NFB to select a suitable NFB or Section 7-3 Fuse Specification Chart.
Electromagnetic contactor	Switching the power ON/OFF before the magnetic contactor more than once per hour can damage the drive.
AC reactor (input terminal)	When the mains power capacity is > 500 kVA or when the drive is preceded by a capacitor bank, the instantaneous peaks voltage and current may destroy the drive. In that case it is recommended to install an AC input reactor that also improves the power factor and harmonics. The cable between reactor and drive should be < 10 m. Please refer to Section 7-4.
Zero-phase reactor	Used to reduce radiated emission, especially in environments with audio devices, and reduce input and output side interference. The effective range is AM band to 10 MHz. Please refer to Section 7-5.
EMC filter	Can be used to reduce electromagnetic interference. Please refer to Section 7-6.
Brake module & Brake resistor (BR)	Used to shorten the deceleration time of the motor. Please refer to Section 7-1.
AC reactor (output terminal)	The wiring length of the motor affects switching current peaks. It is recommended to install an AC output reactor when the motor wiring length exceeds the value listed in Section 7-4.

Table 4-1

4-2 Wiring

Input: one-phase / three-phase power

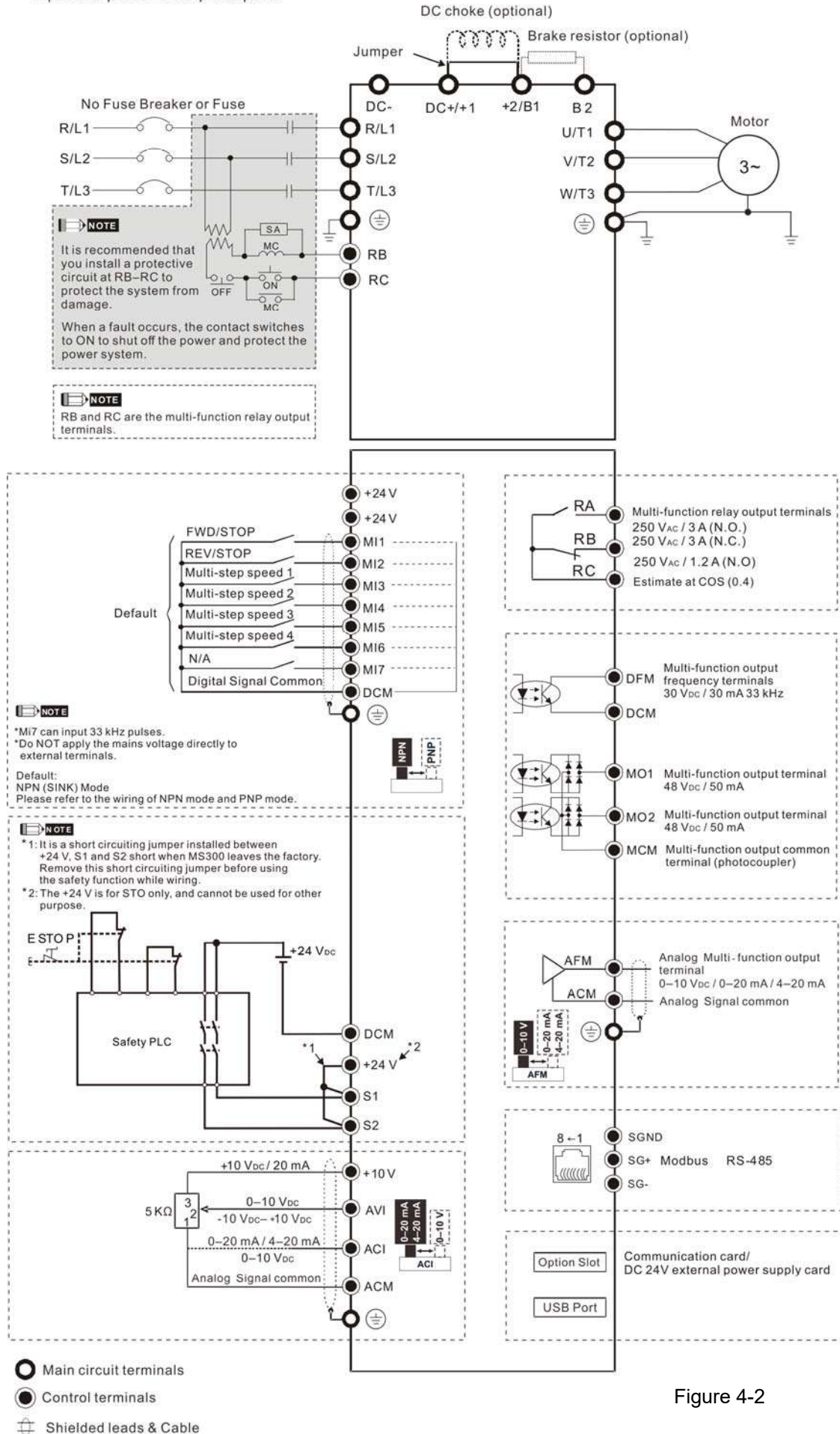
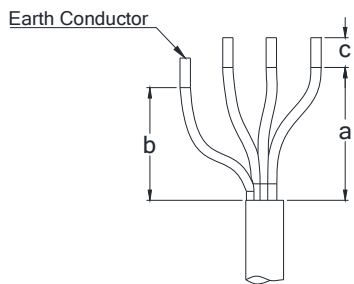
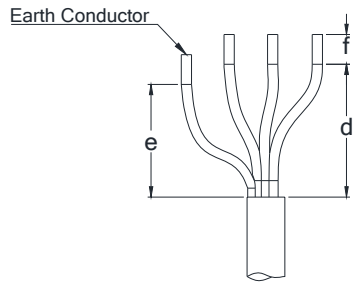

Figure 4-2

The Recommended Value of the Wire To Strip



R/L1, S/L2, T/L3



U/T1, V/T2, W/T3

Frame	R/L1, S/L2, T/L3			U/T1, V/T2, W/T3		
	a	b	c	d	e	f
A	70 [2.76]	60 [2.36]	8 [0.31]	70 [2.76]	60 [2.36]	8 [0.31]
B	60 [2.36]	25 [0.98]	8 [0.31]	60 [2.36]	40 [1.57]	8 [0.31]
C	60 [2.36]	30 [1.18]	8 [0.31]	70 [2.76]	80 [3.15]	8 [0.31]

Unit: mm [inch]

[This page intentionally left blank]

Chapter 5 Main Circuit Terminals

5-1 Main Circuit Diagram

5-2 Main Circuit Terminals



- ☑ Securely fasten the main circuit terminal screws to prevent sparking caused by loose screws due to vibration.
- ☑ When needed, only use an inductive filter at the motor output terminals U/T1, V/T2, W/T3 of the AC motor drive. DO NOT use phase-compensation capacitors or L-C (Inductance-Capacitance) or R-C (Resistance-Capacitance), unless approved by Delta.
- ☑ DO NOT connect brake resistors directly to +1/DC+ to DC-, +2/B1 to DC- to prevent damage to the drive.
- ☑ Ensure proper insulation of the main circuit wiring in accordance with the relevant safety regulations.



Main power terminals

- ☑ DO NOT connect the three-phase drive to one-phase power. R/L1, S/L2 and T/L3 have no phase-sequence requirement; they can be connected in any sequence.
- ☑ Add a magnetic contactor (MC) at the power input to quickly cut off power and reduce malfunction when activating AC motor drive protection function. Both ends of the MC should have an R-C surge absorber.
- ☑ Ensure that voltages and currents are within specification. Refer to Chapter 09 Specifications for details.
- ☑ When using a general GFCI (Ground Fault Circuit Interrupter), select a sensitivity greater than or equal to 200 mA and greater than or equal to 0.1 sec. operation time to avoid nuisance tripping.
- ☑ Use conduits or shielded cables for the power wiring, and ground both ends of the conduit or shielded cables.
- ☑ DO NOT start or stop the drive by turning the power ON or OFF. Start and stop the drive with the RUN/STOP command. If you still need to run or stop the drive by turning power ON or OFF, it is strongly recommended that you do so no more often than ONCE per hour.
- ☑ To comply with UL standards, connect the drive to a three-phase three-wire or three-phase four-wire Wye system type of mains power system.

Output terminals for main circuit

- ☑ Use a well-insulated motor that is suitable for operation with an inverter.
- ☑ When the AC drive output terminals U/T1, V/T2, and W/T3 are connected to the motor terminals U/T1, V/T2, and W/T3 respectively, the motor rotates counterclockwise (as viewed from the shaft end of the motor) when it receives a forward operation command. To permanently reverse the direction of rotation, exchange any two motor leads.

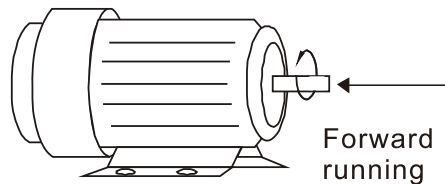
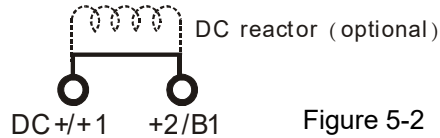

Figure 5-1

Terminals for connecting DC reactor, external brake resistor and DC circuit

- ☑ Terminals for connecting the DC reactor, as shown in Figure 5-2 below, are to improve the power factor and harmonics. At delivery they are shorted by a jumper. Remove the jumper before connecting the DC reactor.
- ☑ You must tightly fasten the jumper when it does not connect the DC reactor, use DC+ / +1, +2 / B1 to execute common DC BUS, or connect with a brake resistor; otherwise the drive might lose power or break the terminals. Refer to Figure 5-2.



- ☑ Connect a brake resistor in applications with frequent deceleration, short deceleration time, too low braking torque, or increased braking torque.

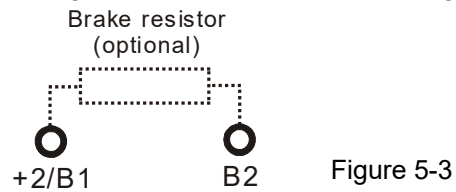

- ☑ Connect the external brake resistor to the terminals [+2/B1], [B2] on AC motor drives.
- ☑ DO NOT short-circuit or connect a brake resistor directly to DC+ / +1 and DC-, +2/B1 to DC-; otherwise the drive will be damaged.
- ☑ Connect DC+ and DC- in common DC BUS applications. Refer to Section 5-1 (Main Circuit Terminal) for the wiring terminal specification and the wire gauge information.

Open the front cover

- 📖 Open the front cover before connecting the main circuit terminals and control circuit terminals. Open the cover according to the Figure 5-4 and Figure 5-5 below.
- 📖 The figure below shows the Frame B model for example. Opening the cover on the other frame sizes is similar.

- ① Loosen the four screws on the front cover with a Phillips head screwdriver.
- ② Open the front cover to the left.

Torque:
4–6 kg-cm /
[3.5–5.2 lb-in.] /
[0.39–0.59 Nm]

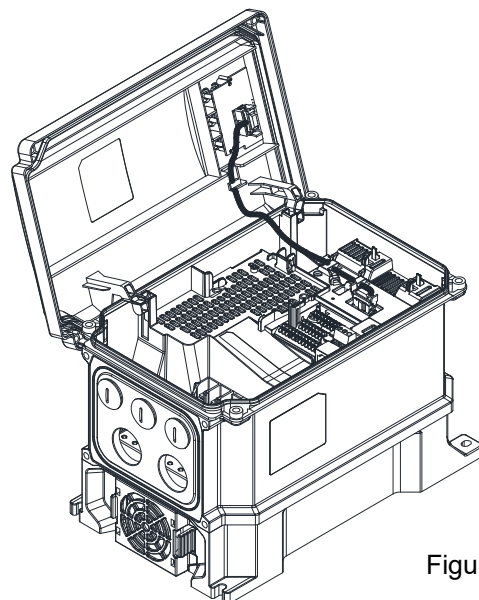
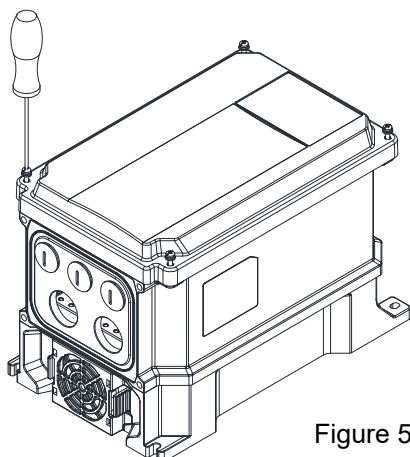

5-1 Main Circuit Diagram

Input: one-phase / three-phase power

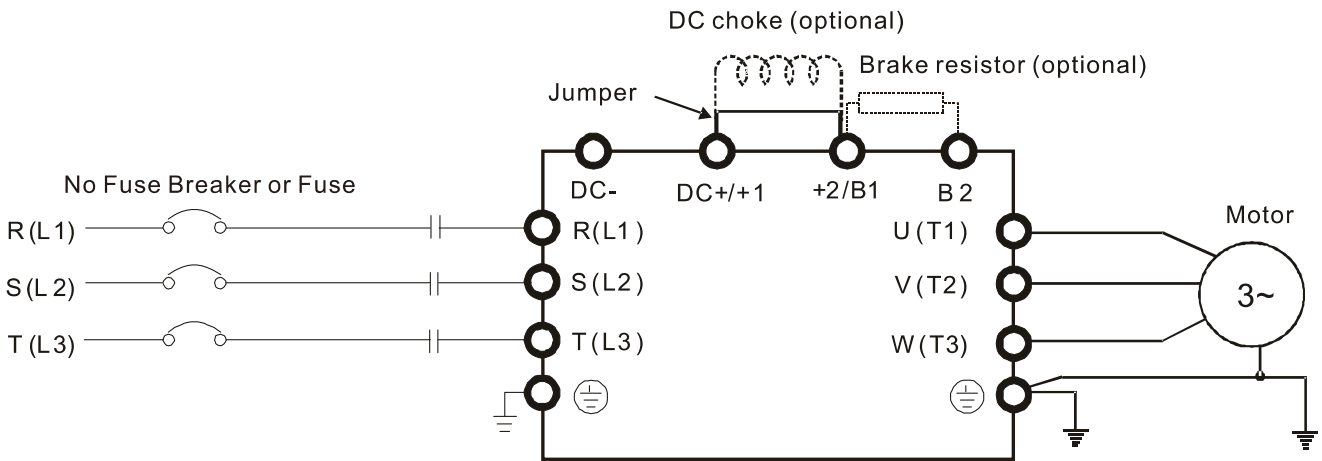

Figure 5-6

Terminals	Descriptions
R/L1, S/L2	Mains input terminals one-phase
R/L1, S/L2, T/L3	Mains input terminals three-phase
U/T1, V/T2, W/T3	Motor output terminals for connecting three-phase IM and PM motors.
+1, +2	Connections for DC reactor to improve the power factor and harmonics. Remove the jumper when using a DC reactor.
DC+, DC-	Connections for brake unit (VFDB series) Common DC BUS
B1, B2	Connections for brake resistor (optional). Refer to Section 7-1 for details.
⊕	Ground connection, comply with local regulations.

Table 5-1

5-2 Main Circuit Terminals

- Use the specified ring lug for main circuit terminal wiring. See Figure 5-7 and Figure 5-8 for ring lug specifications. For other types of wiring, use the wires that comply with the local regulations.
- After crimping the wire to the ring lug (must be UL and CSA approved R/C (YDPU2)), then install heat shrink tubing rated at a minimum of 600 V_{AC} insulation over the live part. Refer to Figure 5-8 below.
- Main circuit terminals:
R/L1, S/L2, T/L3, U/T1, V/T2, W/T3, ⊕, DC-, DC+/-1, +2/B1, B2
Note: One-phase model with no T/L3 terminal

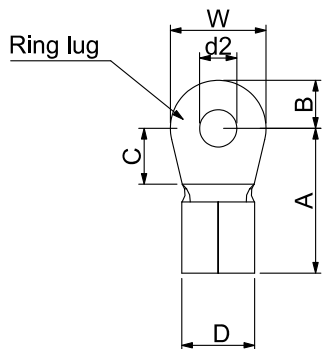

Figure 5-7

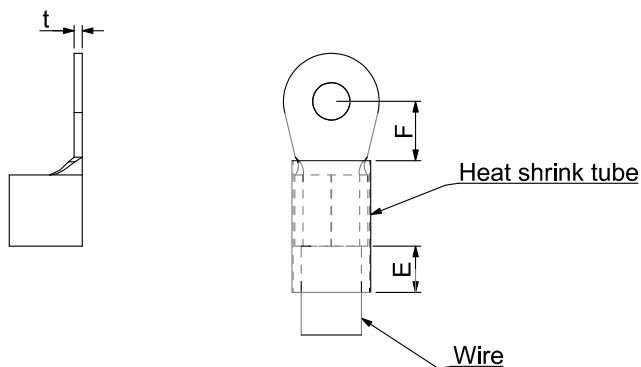

Figure 5-8

Dimensions of Ring Lug

The part # of the ring lugs (produced by K.S. Terminals Inc.) in the table below are for reference only. You can buy other ring lugs of your choice to match with different frame sizes.

Unit: mm

Frame	*AWG	Kit P/N	A (MAX)	B (MAX)	C (MIN)	D (MAX)	d2 (MIN)	E (MIN)	F (MIN)	W (MAX)	t (MAX)
A	18	RNBS1-4	11.1	4.0	6.3	3.4	4.3	13.0	4.5	6.6	0.8
	16	RNBS1-4									
	14	RNBS2-4	12.1		5.6	7.2			1		
	12	RNBS5-4									
B	14	RNBS2-4	17.8	5.0	6.1	7.2	4.3	13.0	5.5	8.0	1.2
	12	RNBS5-4									
	10	RNBS5-4									
	8	RNBS8-4									
C	14	RNBS2-4	17.8	5.0	6.1	7.2	4.3	13.0	5.5	8.0	1.2
	12	RNBS5-4									
	10	RNBS5-4									
	8	RNBS8-4									

Table 5-2

*AWG: For the wire gauge of each model, Frame A refers to Table 5-3, Frame B refers to Table 5-4, and Frame C refers to Table 5-5.

Frame A

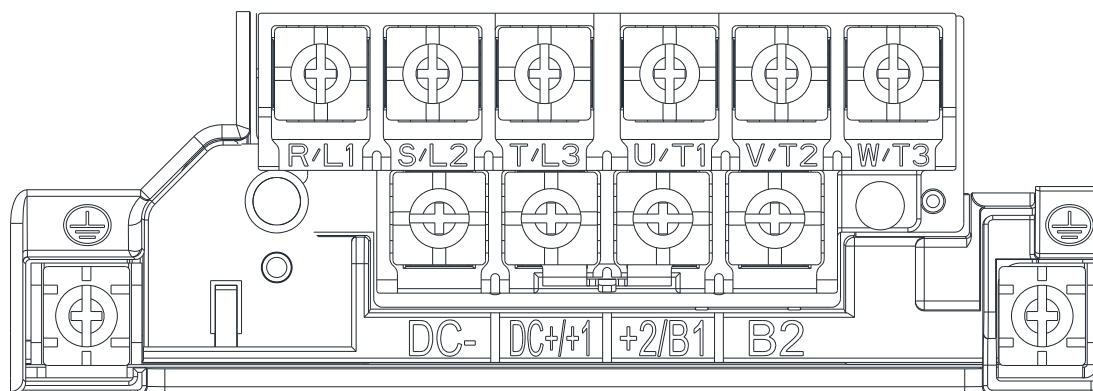

- If you install at Ta 40 °C environment, select copper wire with voltage rating of 600 V and temperature resistance of 75 °C or 90 °C.
- If you install at Ta 40 °C above environment, select copper wire with voltage rating of 600 V and temperature resistance of 90 °C or above.
- For UL installation compliance, use copper wires when installing. The wire gauge is based on a temperature resistance of 75 °C, in accordance with UL requirements and recommendations. Do not reduce the wire gauge when using high-temperature resistant wires.

Models	Main Circuit Terminals R/L1, S/L2, T/L3, U/T1, V/T2, W/T3, DC-, DC+/+1, +2/B1, B2			Ground Terminals ⊕		
	Max. Wire Gauge	Min. Wire Gauge	Screw and Torque (±10 %)	Max. Wire Gauge	Min. Wire Gauge	Screw and Torque (±10 %)
VFD2A8MS21MNSAA	2.5 mm ² [14 AWG]	2.5 mm ² [14 AWG]	M3.5 9 kg-cm [7.8 lb-in.] [0.88 Nm]	2.5 mm ² [14 AWG]	2.5 mm ² [14 AWG]	M4 20 kg-cm [17.4 lb-in.] [1.96 Nm]
VFD2A8MS23MNSAA		0.75 mm ² [18 AWG]				
VFD4A8MS23MNSAA		1.5 mm ² [16 AWG]				
VFD1A5MS43MNSAA		0.75 mm ² [18 AWG]				
VFD2A7MS43MNSAA						
VFD2A8MS21MFSAA	4 mm ² [12 AWG]	2.5 mm ² [14 AWG]	M4 15 kg-cm [13.0 lb-in.] [1.47 Nm]	4 mm ² [12 AWG]	4 mm ² [12 AWG]	
VFD4A8MS21MNSAA		4 mm ² [12 AWG]				
VFD4A8MS21MFSAA						
VFD7A5MS23MNSAA		2.5 mm ² [14 AWG]		2.5 mm ² [14 AWG]	2.5 mm ² [14 AWG]	
VFD1A5MS43MFSAA		0.75 mm ² [18 AWG]				
VFD2A7MS43MFSAA						
VFD4A2MS43MNSAA		1.5 mm ² [16 AWG]				
VFD4A2MS43MFSAA						
VFD7A5MS21MNSAA	6 mm ² [10 AWG]	6 mm ² [10 AWG]	M4 20 kg-cm [17.4 lb-in.] [1.96 Nm]	6 mm ² [10 AWG]	6 mm ² [10 AWG]	
VFD5A5MS43MNSAA		2.5 mm ² [14 AWG]		2.5 mm ² [14 AWG]	2.5 mm ² [14 AWG]	

Table 5-3

Frame B

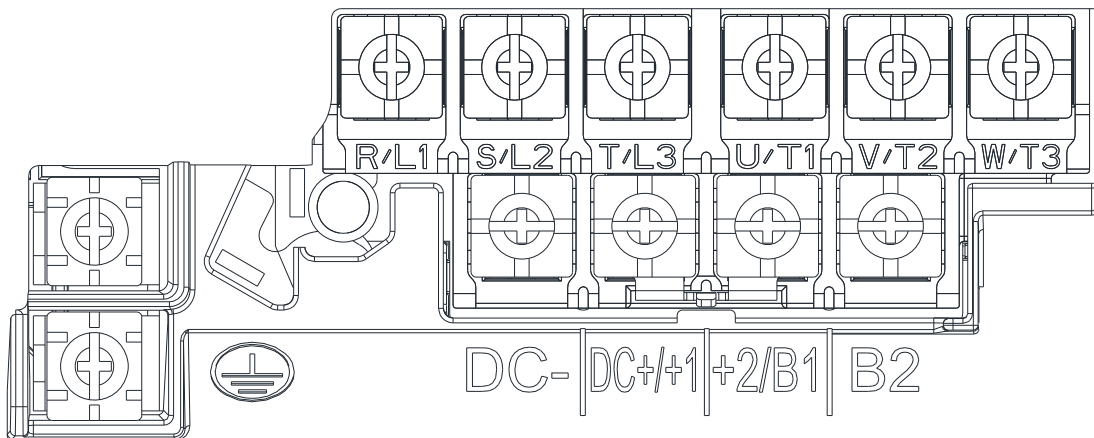

- If you install at Ta 40 °C environment, select copper wire with voltage rating of 600 V and temperature resistance of 75 °C or 90 °C.
- If you install at Ta 40 °C above environment, select copper wire with voltage rating of 600 V and temperature resistance of 90 °C or above.
- For UL installation compliance, use copper wires when installing. The wire gauge is based on a temperature resistance of 75 °C, in accordance with UL requirements and recommendations. Do not reduce the wire gauge when using high-temperature resistant wires.

Models	Main Circuit Terminals R/L1, S/L2, T/L3, U/T1, V/T2, W/T3, DC-, DC+ / +1, +2/B1, B2			Ground Terminals ⊕		
	Max. Wire Gauge	Min. Wire Gauge	Screw and Torque (±10 %)	Max. Wire Gauge	Min. Wire Gauge	Screw and Torque (±10 %)
VFD7A5MS21MFSAA	10 mm ² [8 AWG]	6 mm ² [10 AWG]	M4 20 kg-cm [17.4 lb-in.] [1.96 Nm]	6 mm ² [10 AWG]	6 mm ² [10 AWG]	M4 20 kg-cm [17.4 lb-in.] [1.96 Nm]
VFD11AMS21MNSAA		10 mm ² [8 AWG]		10 mm ² [8 AWG]	10 mm ² [8 AWG]	
VFD11AMS21MFSAA		6 mm ² [10 AWG]		6 mm ² [10 AWG]	6 mm ² [10 AWG]	
VFD11AMS23MNSAA		10 mm ² [8 AWG]		10 mm ² [8 AWG]	10 mm ² [8 AWG]	
VFD17AMS23MNSAA		2.5 mm ² [14 AWG]		2.5 mm ² [14 AWG]	2.5 mm ² [14 AWG]	
VFD5A5MS43MFSAA		4 mm ² [12 AWG]		4 mm ² [12 AWG]	4 mm ² [12 AWG]	
VFD9A0MS43MNSAA						
VFD9A0MS43MFSAA						

Table 5-4

Frame C

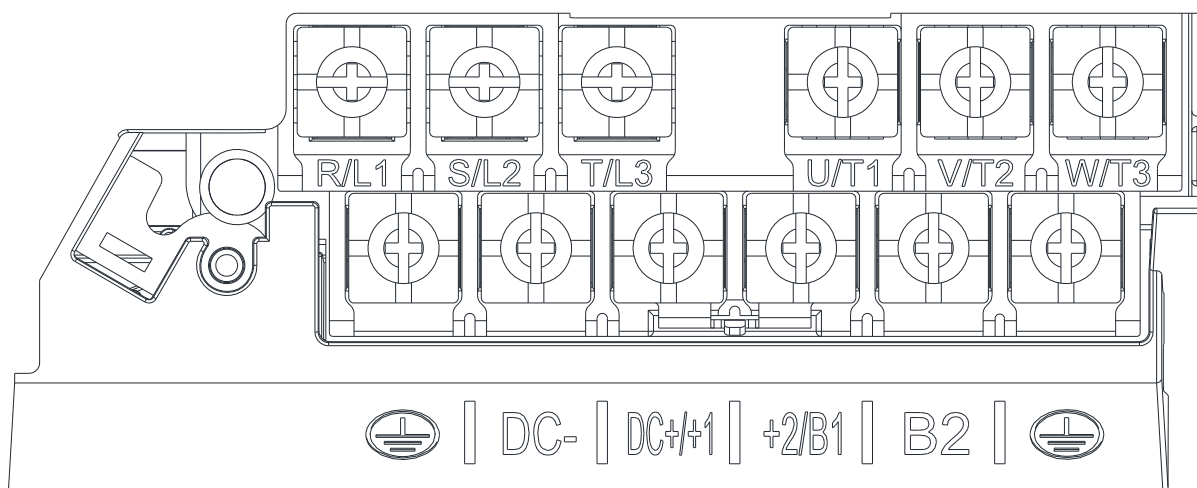

- If you install at Ta 40 °C environment, select copper wire with voltage rating of 600 V and temperature resistance of 75 °C or 90 °C.
- If you install at Ta 40 °C above environment, select copper wire with voltage rating of 600 V and temperature resistance of 90 °C or above.
- For UL installation compliance, use copper wires when installing. The wire gauge is based on temperature resistance of 75 °C, in accordance with UL requirements and recommendations. Do not reduce the wire gauge when using high-temperature resistant wires.

Models	Main Circuit Terminals R/L1, S/L2, T/L3, U/T1, V/T2, W/T3, DC-, DC+ / +1, +2/B1, B2			Ground Terminals ⊕		
	Max. Wire Gauge	Min. Wire Gauge	Screw and Torque (±10 %)	Max. Wire Gauge	Min. Wire Gauge	Screw and Torque (±10 %)
VFD25AMS23MNSAA	10 mm ² [8 AWG]	10 mm ² [8 AWG]	M4 20 kg-cm [17.4 lb-in.] [1.96 Nm]	10 mm ² [8 AWG]	10 mm ² [8 AWG]	M4 20 kg-cm [17.4 lb-in.] [1.96 Nm]
VFD13AMS43MNSAA		6 mm ² [10 AWG]		6 mm ² [10 AWG]	6 mm ² [10 AWG]	
VFD13AMS43MFSAA		10 mm ² [8 AWG]		10 mm ² [8 AWG]	10 mm ² [8 AWG]	
VFD17AMS43MNSAA						
VFD17AMS43MFSAA						

Table 5-5

Chapter 6 Control Circuit Terminals

6-1 Control Circuit Terminal Specifications

Analog input terminals (AVI, ACI, ACM)

- ☑ Analog input signals are easily affected by external noise. Use shielded wiring and keep it as short as possible (less than 20 m) with proper grounding. If the noise is inductive, connecting the shield to the ACM terminal can reduce interference.
- ☑ Use twisted-pair wire for weak analog signals.
- ☑ If the analog input signals are affected by noise from the drive, connect a capacitor and ferrite core as shown in Figure 6-1 below.

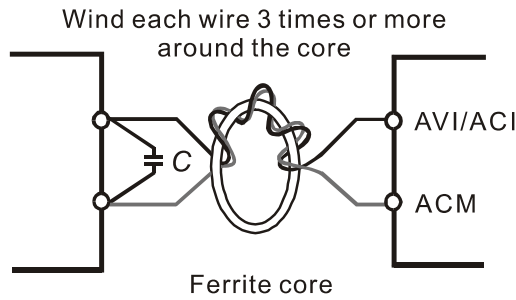

Figure 6-1

Contact input terminals (MI1–MI7, DCM, +24 V)

- ① Sink Mode with internal power (+24 V_{DC})

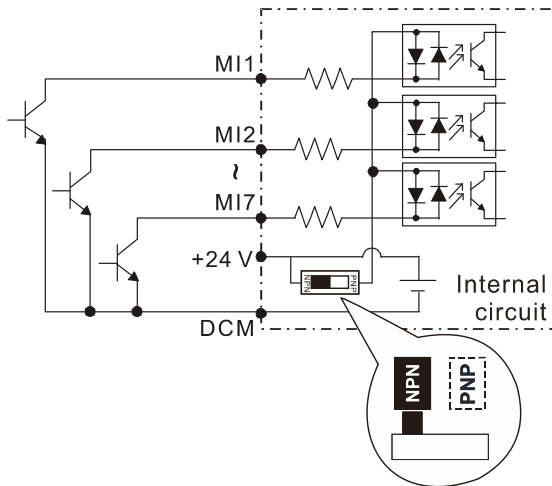

Figure 6-2

- ② Source Mode with internal power (+24 V_{DC})

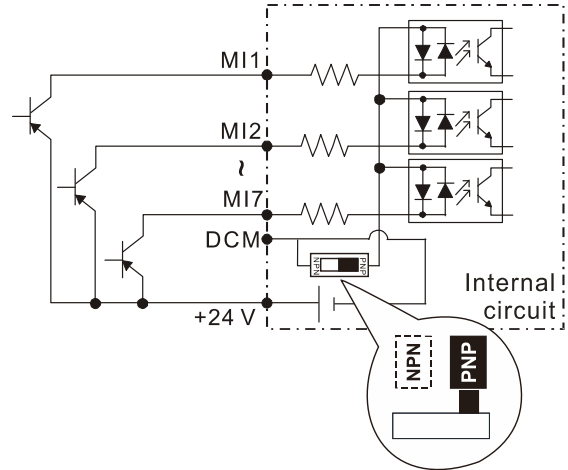

Figure 6-3

- ③ Sink Mode with external power

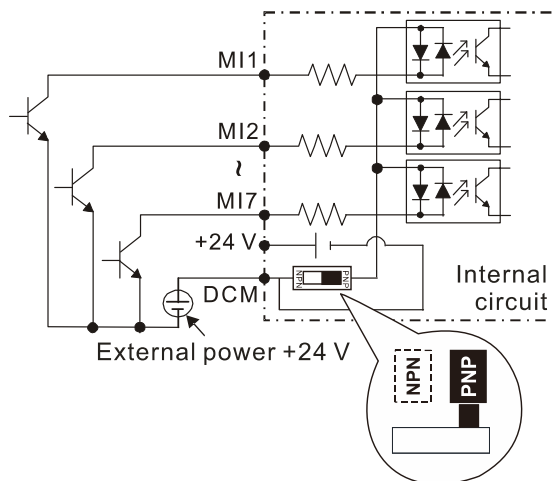

Figure 6-4

- ④ Source Mode with external power

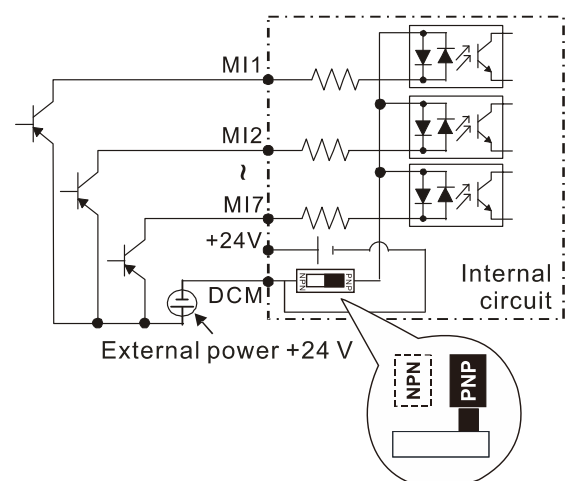

Figure 6-5

- ☑ When the photo coupler is using the internal power supply, the switch connection for Sink and Source modes are as shown in Figure 6-2 and Figure 6-3 above:
MI-DCM: Sink mode, MI-+24V: Source mode.

Transistor output terminals (MO1, MO2, MCM)

- ☑ Make sure to connect the digital outputs to the correct polarity. See the wiring diagram when connecting a relay to the digital output, connect a surge absorber across the coil, and check the polarity.

6-1 Control Circuit Terminal Specifications

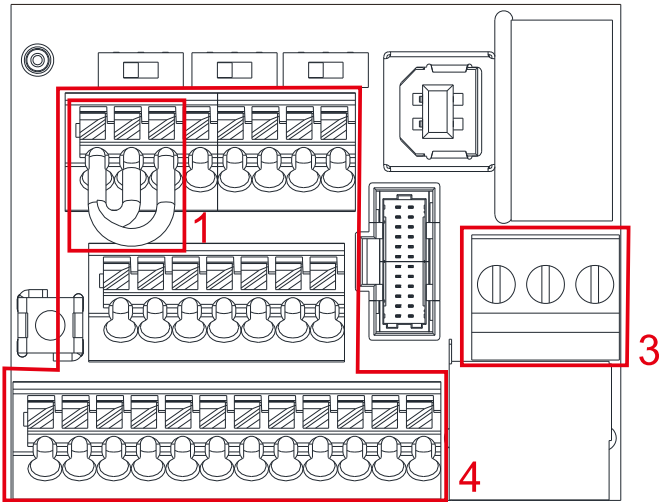

Control Circuit Terminal Distribution Diagram
Figure 6-6

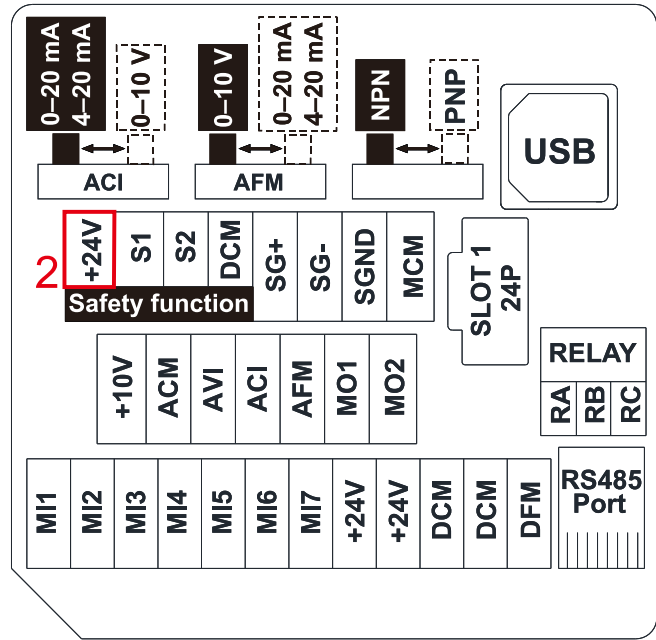

Control Circuit Terminal Location Map
Figure 6-7

Wiring precautions:

1. The factory default condition is +24 V/ S1/ S2 shorted by jumper, as shown in the block 1 of the figure above. Refer to the Figure 4-2 in Chapter 4 WIRING for more details.
2. The +24 V power supply for safety function, as shown in the block 2 of the figure above. This is only for STO use and cannot be used for other purposes.
3. The RELAY terminal uses the PCB terminal block (as shown in the block 3 of the figure above):
 - Tighten the wiring with a 3.5 mm width and 0.6 mm thickness slotted screwdriver.
 - The ideal length of stripped wire at the connection side is 6–7 mm.
 - When wiring bare wires, make sure they are perfectly arranged to go through the wiring holes.
4. The control circuit terminal uses a spring clamp terminal block (as shown in the block 4 of the figure above):
 - Tighten the wiring with a 2.5 mm width and 0.4 mm thickness slotted screwdriver.
 - The ideal length of stripped wire at the connection side is 9 mm.

Wiring Specifications of Control Circuit Terminals:

Terminal Name	Wiring Specifications of Control Circuit Terminals	Length of Stripped Wire (mm)	Max. Wire Gauge	Min. Wire Gauge	Torque
RELAY Terminal	Solid	6–7	1.5 mm ² [16 AWG]	0.2 mm ² [24 AWG]	5 kg-cm [4.3 lb-in.] [0.49 Nm]
	Strand				
Control Circuit Terminal	Solid	9	0.75 mm ² [18 AWG]	0.25 mm ² [24 AWG]	/
	Strand				
	Stranded with ferrules with plastic sleeve	9	0.5 mm ² [20 AWG]		

Table 6-1

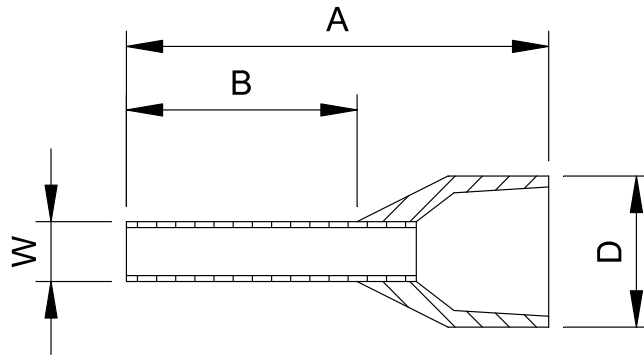

Figure 6-8

Recommended models or dimensions for ferrule terminals

Unit: mm

Wire Gauge	Manufacturer	Model Name	A (MAX)	B (MAX)	D (MAX)	W (MAX)
0.25 mm ² [24 AWG]	PHOENIX CONTACT	AI 0,25- 8 YE	12.5	8	2.6	1.1
0.34 mm ² [22 AWG]	PHOENIX CONTACT	AI 0,34- 8 TQ	12.5	8	3.3	1.3
0.5 mm ² [20 AWG]	PHOENIX CONTACT	AI 0,5 - 8 WH	14	8	3.5	1.4

Recommended specifications and models for ferrules:
 CRIMPFOX 10S - 1212045, Manufacturer: PHOENIX CONTACT
 DNT13-0101, Manufacturer: DINKLE

Table 6-2

Terminals	Terminal Function	Default (NPN mode)
+24 V	Digital control signal common (Source)	+24 V \pm 10 % 100 mA
MI1 – MI7	Multi-function input 1–7	Refer to Pr.02-01–02-07 to program the multi-function inputs MI1–MI7. Source Mode ON: the activation current is 3.3 mA \geq 11 V _{DC} OFF: cut-off voltage \leq 5 V _{DC} Sink Mode ON: the activation current is 3.3 mA \leq 13 V _{DC} OFF: cut-off voltage \geq 19 V _{DC} ■ When Pr.02-00 = 0, MI1 and MI2 can be programmed. ■ When Pr.02-00 \neq 0, the function of MI1 and MI2 is according to Pr.02-00 setting. ■ When Pr.02-07 = 0, MI7 is pulse input with maximum frequency 33 kHz (See Pr.10-00, Pr.10-02, Pr.10-16).

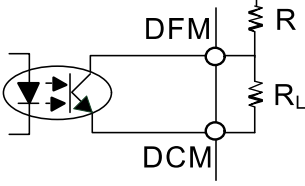
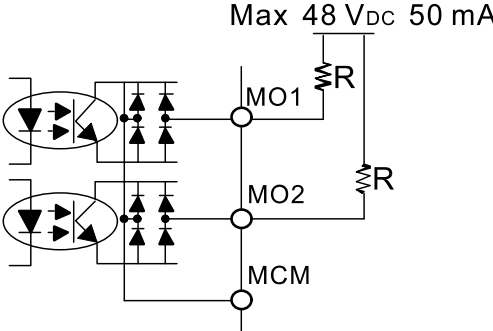
Terminals	Terminal Function	Default (NPN mode)
DFM	Digital frequency meter Max 30 V _{DC} 30 mA  Figure 6-9	DFM is a pulse-signal output; Duty-cycle: 50 % Minimum load impedance R _L : 1 kΩ/100 pF Maximum current: 30 mA Maximum capacitive load: 100 pF Maximum voltage: 30 V _{DC} ± 1 % (when 30 V _{DC} / 30 mA / R _L = 100 pF) Maximum output frequency: 33 kHz
DCM	Digital frequency signal common (Sink)	Internal current limiting resistor R: ≥ 1 KΩ Output load impedance R _L Capacitive load ≤ 100 pF Resistive load ≥ 1 kΩ resistance determines the output voltage value. DFM-DCM voltage = external voltage * (R _L / (R _L +R))
MO1	Multi-function Output 1 (photo coupler)	Programmable open-collector outputs, see Pr.02-16 and Pr.02-17.  Figure 6-10
MO2	Multi-function Output 2 (photo coupler)	
MCM	Multi-function Output Common (photo coupler)	
RA	Multi-function relay output 1 (Relay N.O. a)	Programmable relay output, see Pr.02-13. Resistive Load 3 A (N.O.) / 3 A (N.C.) 250 V _{AC} 5 A (N.O.) / 3 A (N.C.) 30 V _{DC}
RB	Multi-function relay output 1 (Relay N.C. b)	Inductive Load (COS 0.4) 1.2 A (N.O.) / 1.2 A (N.C.) 250 V _{AC} 2.0 A (N.O.) / 1.2 A (N.C.) 30 V _{DC}
RC	Multi-function relay common (Relay)	Various kinds of monitor signals output, e.g.: operation, frequency reached, overload indication etc.
+10 V	Potentiometer power supply	+10.5±0.5 V _{DC} / 20 mA

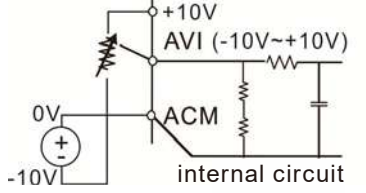
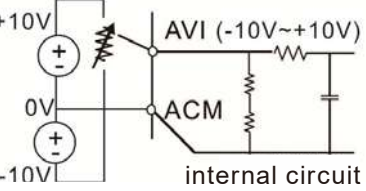
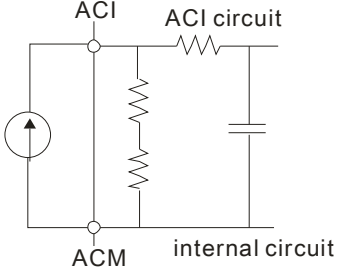
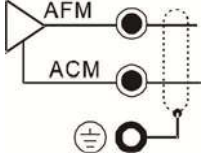
Terminals	Terminal Function	Default (NPN mode)
AVI	<p>Analog voltage input</p>  <p>Figure 6-11</p>  <p>Figure 6-12</p>	<p>Impedance: 20 kΩ</p> <p>Range 0–Maximum Output Frequency (Pr.01-00): 0–10 V / -10–10 V</p> <p>Range switching by Pr.03-00, Pr.03-28.</p> <p>AVI resolution = 10 bits</p>
ACI	<p>Analog current input</p>  <p>Figure 6-13</p>	<p>Impedance: Current mode is 250 Ω; voltage mode is 20 kΩ.</p> <p>Range 0–Maximum Output Frequency (Pr.01-00): 0–20 mA / 4–20 mA / 0–10 V</p> <p>Range switching by Pr.03-01, Pr.03-29.</p> <p>ACI resolution = 12 bits</p>
AFM	<p>Multi-function analog voltage output</p>  <p>Figure 6-14</p>	<p>Switch: the AFM default is 0–10 V (voltage mode). Use the switch and Pr.03-31 to change to current mode (0–20 mA / 4–20 mA). You must follow the indication on the back side of the front cover or page 6-1 of the user manual when using the switch.</p> <p>Voltage mode</p> <p>Range: 0–10 V (Pr.03-31=0) corresponding to the maximum operating range of the control object</p> <p>Maximum output current : 2 mA</p> <p>Maximum Load: 5 kΩ</p> <p>Current mode</p> <p>Range: 0–20 mA (Pr.03-31=1) / 4–20 mA (Pr.03-31=2) corresponding to the maximum. operating range of the control object</p> <p>Maximum load: 500 Ω</p> <p>AFM resolution = 10 bits</p>
ACM	<p>Analog Signal Common</p>	<p>Common for analog terminals</p>

Terminals	Terminal Function	Default (NPN mode)
S1, S2	<p>Default: S1/S2 shorted for +24 V</p> <p>Rated voltage: $24 V_{DC} \pm 10 \%$; Max. voltage: $30 V_{DC} \pm 10 \%$</p> <p>Activation current: $6.67 \text{ mA} \pm 10 \%$</p> <p>STO activation mode</p> <p>Input voltage level: S1-DCM > 0 V_{DC} or S2-DCM < 5 V_{DC}</p>	
DCM	<p>STO response time $\leq 20 \text{ ms}$. S1/S2 operates until the AC motor drive stops outputting current.</p> <p>STO cut-off mode</p> <p>Input voltage level: S1-DCM > 11 V_{DC} and S2-DCM < 30 V_{DC}</p> <p>Power removal safety function according to EN 954-1 and IEC / EN 61508</p> <p>Note: refer to Chapter 17 SAFE TORQUE OFF FUNCTION for more information.</p>	
SG+	Modbus RS-485	
SG-	Note: refer to Chapter 12 DESCRIPTION OF PARAMETER SETTINGS for more information (page 12-09-1–page 12-09-17).	
SGND		
RJ45	<p>PIN 1, 2, 6: Reserved PIN 3, 7: SGND PIN 4: SG-</p> <p>PIN 5: SG+ PIN 8: +10 V supply (provide KPC-CC01 power supply)</p>	

* Analog control signal wiring specification: 0.82 mm² [18 AWG] with shielded stranded wire

Table 6-3

Chapter 7 Optional Accessories

- 7-1 All Brake Resistors and Brake Units Used in AC Motor Drives
- 7-2 Non-fuse Circuit Breaker
- 7-3 Fuse Specification Table
- 7-4 AC/DC Reactor
- 7-5 Zero Phase Reactors
- 7-6 EMC Filter
- 7-7 EMC Shield Plate
- 7-8 Capacitive Filter
- 7-9 Fan Kit
- 7-10 Main Switch

The optional accessories listed in this chapter are available upon request. Installing additional accessories to your drive substantially improves the drive's performance. Select accessories according to your need or contact your local distributor for suggestions.

7-1 All Brake Resistors and Brake Units Used in AC Motor Drives

230V one-phase

Model	Applicable Motor		*1 125 % Braking Torque 10 % ED					Max. Braking Torque			
	HP	kW	*2 Braking Torque [kg-m]	Resistor Value Spec. for Each AC Motor Drive	Braking Resistor for Each Brake Unit			Braking Current [A]	Min. Resistor Value [Ω]	Max. Total Braking Current [A]	Peak Power [kW]
					*3 Part No.	Amount	Usage				
VFD2A8MS21MNSXX VFD2A8MS21MFSXX	0.5	0.4	0.3	80W 200Ω	BR080W200	1	-	1.9	95.0	4	1.5
VFD4A8MS21MNSXX VFD4A8MS21MFSXX	1	0.75	0.5	80W 200Ω	BR080W200	1	-	1.9	63.3	6	2.3
VFD7A5MS21MNSXX VFD7A5MS21MFSXX	2	1.5	1	200W 91Ω	BR200W091	1	-	4.2	47.5	8	3.0
VFD11AMS21MNSXX VFD11AMS21MFSXX	3	2.2	1.5	300W 70Ω	BR300W070	1	-	5.4	38.0	10	3.8

230V three-phase

Model	Applicable Motor		*1 125 % Braking Torque 10 % ED					Max. Braking Torque			
	HP	kW	*2 Braking Torque [kg-m]	Resistor Value Spec. for Each AC Motor Drive	Braking Resistor for Each Brake Unit			Braking Current [A]	Min. Resistor Value [Ω]	Max. Total Braking Current [A]	Peak Power [kW]
					*3 Part No.	Amount	Usage				
VFD1A6MS23MNSXX	0.25	0.2	0.1	80W 750Ω	BR080W750	1	-	0.5	190.0	2	0.8
VFD2A8MS23MNSXX	0.5	0.4	0.3	80W 200Ω	BR080W200	1	-	1.9	95.0	4	1.5
VFD4A8MS23MNSXX	1	0.75	0.5	80W 200Ω	BR080W200	1	-	1.9	63.3	6	2.3
VFD7A5MS23MNSXX	2	1.5	1	200W 91Ω	BR200W091	1	-	4.2	47.5	8	3.0
VFD11AMS23MNSXX	3	2.2	1.5	300W 70Ω	BR300W070	1	-	5.4	38.0	10	3.8
VFD17AMS23MNSXX	5	3.7	2.5	400W 40Ω	BR400W040	1	-	9.5	19.0	20	7.6

460V three-phase

Model	Applicable Motor		*1 125 % Braking Torque 10 % ED					Max. Braking Torque			
	HP	kW	*2 Braking Torque [kg-m]	Resistor Value Spec. for Each AC Motor Drive	Braking Resistor for Each Brake Unit			Braking Current [A]	Min. Resistor Value [Ω]	Max. Total Braking Current [A]	Peak Power [kW]
					*3 Part No.	Amount	Usage				
VFD1A5MS43MNSXX VFD1A5MS43MFSXX	0.5	0.4	0.3	80W 750Ω	BR080W750	1	-	1	380.0	2	1.5
VFD2A7MS43MNSXX VFD2A7MS43MFSXX	1	0.75	0.5	80W 750Ω	BR080W750	1	-	1	190.0	4	3.0
VFD4A2MS43MNSXX VFD4A2MS43MFSXX	2	1.5	1	200W 360Ω	BR200W360	1	-	2.1	126.7	6	4.6
VFD5A5MS43MNSXX VFD5A5MS43MFSXX	3	2.2	1.5	300W 250Ω	BR300W250	1	-	3	108.6	7	5.3
VFD9A0MS43MNSXX VFD9A0MS43MFSXX	5	3.7	2.5	400W 150Ω	BR400W150	1	-	5.1	84.4	9	6.8
VFD13AMS43MNSXX VFD13AMS43MFSXX	7.5	5.5	3.7	1000W 75Ω	BR1K0W075	1	-	10.2	50.7	15	11.4
VFD17AMS43MNSXX VFD17AMS43MFSXX	10	7.5	5.1	1000W 75Ω	BR1K0W075	1	-	10.2	40.0	19	14.4

*1 Standard braking torque is 125%. Because of the limited resistor power, the longest operation time for 10% ED is 10 seconds (on: 10 seconds / off: 90 seconds).

- *2 Calculation for braking torque is for a four-pole motor 1800 rpm.
- *3 Resistors of 400 W or lower should be fixed to the frame and at a surface temperature below 250°C (400°C). Resistors of 1000 W and above should be fixed on a surface with temperature below 600°C (If the temperature is higher than the resistance temperature limit, install a heat dissipation system or increase the resistance power.).

NOTE

1. Select the resistance value, power and brake usage (ED %) according to Delta rules.

Definition for Brake Usage ED%

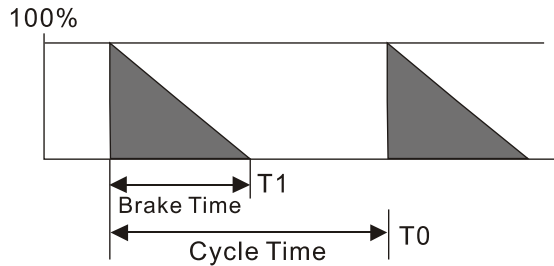

$$ED\% = T1/T0 \times 100 (\%)$$

Explanation:
ED (%) is defined to allow enough time for the brake unit and brake resistor to dissipate the heat generated by braking. Recommended cycle time T0 is one minute.

For safety, install a thermal overload relay (O.L) between the brake unit and the brake resistor in conjunction with the magnetic contactor (MC) before the drive for additional protection. The thermal overload relay protects the brake resistor from damage due to frequent or continuous braking. Under such circumstances, turn off the power to prevent damage to the brake resistor, brake unit and drive.

2. Any damage to the drive or other equipment caused by using brake resistors and brake modules that are not provided by Delta voids the warranty.
3. Consider environmental safety factors when installing the brake resistors. If you use the minimum resistance value, consult local dealers for the power calculation.
4. When using more than two brake units, the equivalent resistor value of the parallel brake unit cannot be less than the value in the column "Minimum Resistor Value [Ω]". Read the wiring information in the brake unit user manual thoroughly prior to operation.
5. These are recommendations that only for normal applications. For frequent braking applications, increase the wattage two to three times.
6. Thermal Overload Relay (TOR):

Choosing a thermal overload relay is based on whether its overload capacity is appropriate for the MS300. The standard braking capacity of the MS300 is 10% ED (Tripping time=10 s). As shown in the figure below, the thermal overload relay continuously operates for 10 seconds and it can withstand a 260% overload (Host starting). For example, a 460V, 15 kW MS300 has a braking current of 24 A (refer to the tables in this section), so it can use the thermal overload relay with a rated current of 10 A (10*260% = 26 A > 24 A).

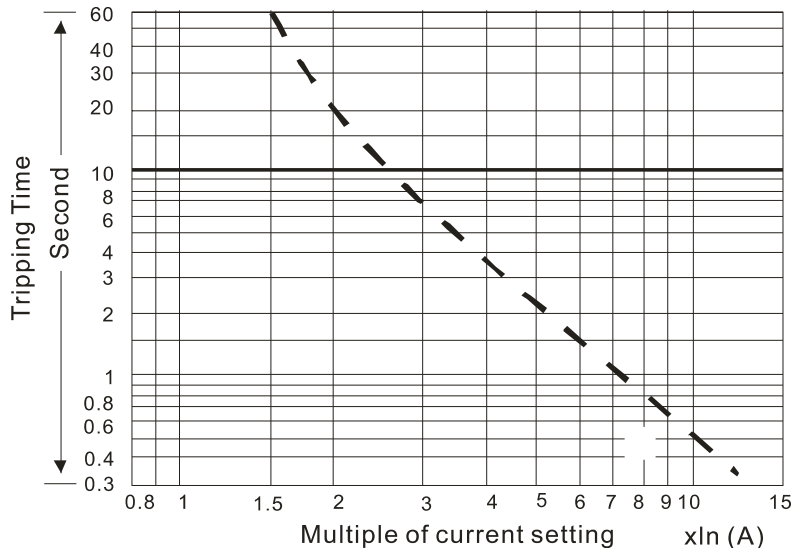

7-2 Non-fuse Circuit Breaker

Comply with the UL standard: Per UL 508, paragraph 45.8.4, part a.

The rated current of the non-fuse circuit breaker should be 1.6–2.6 times the drive’s rated input current. The recommended current values are shown in the table below.

Compare the time characteristics of the non-fuse circuit breaker with those of the drive’s overheated protection to ensure that there is no tripping.

Model	Voltage / one-phase (three-phase)	Current Input / Output (Maximum)		Recommend Current [A]
		Normal Duty	Heavy Duty	
VFD2A8MS21MNSXX VFD2A8MS21MFSXX	230V / one-phase	6.7 A / 3.2 A	5.9 A / 2.8 A	16
VFD4A8MS21MNSXX VFD4A8MS21MFSXX		10.5 A / 5.0 A	10.1 A / 4.8 A	25
VFD7A5MS21MNSXX VFD7A5MS21MFSXX		17.9 A / 8.5 A	15.8 A / 7.5 A	45
VFD11AMS21MNSXX VFD11AMS21MFSXX		26.3 A / 12.5 A	23.1 A / 11.0 A	63
VFD2A8MS23MNSXX	230V / three-phase	3.8 A / 3.2 A	3.4 A / 2.8 A	10
VFD4A8MS23MNSXX		6.0 A / 5.0 A	5.8 A / 4.8 A	15
VFD7A5MS23MNSXX		9.6 A / 8.0 A	9.0 A / 7.5 A	25
VFD11AMS23MNSXX		15.0 A / 12.5 A	13.2 A / 11.0 A	40
VFD17AMS23MNSXX		23.4 A / 19.5 A	20.4 A / 17.0 A	60
VFD25AMS23MNSXX		32.4 A / 27.0 A	30.0 A / 25.0 A	63
VFD1A5MS43MNSXX VFD1A5MS43MFSXX	460V / three-phase	2.5 A / 1.8 A	2.1 A / 1.5 A	6
VFD2A7MS43MNSXX VFD2A7MS43MFSXX		4.2 A / 3.0 A	3.7 A / 2.7 A	10
VFD4A2MS43MNSXX VFD4A2MS43MFSXX		6.4 A / 4.6 A	5.8 A / 4.2 A	16
VFD5A5MS43MNSXX VFD5A5MS43MFSXX		7.2 A / 6.5 A	6.1 A / 5.5 A	16
VFD9A0MS43MNSXX VFD9A0MS43MFSXX		11.6 A / 10.5 A	9.9 A / 9.0 A	30
VFD13AMS43MNSXX VFD13AMS43MFSXX		17.3 A / 15.7 A	14.3 A / 13.0 A	32
VFD17AMS43MNSXX VFD17AMS43MFSXX		22.6 A / 20.5 A	18.7 A / 17.0 A	45

7-3 Fuse Specification Table

- ☑ Use only the test approved fuse specifications as listed in the table below. Do not use values larger than the values listed in the fuse specification table. Using AC input values smaller than the listed values is allowed only when the fuse current root mean square value is larger than the actual input current value. If the drive operates under an overloaded condition, that is, 150% of its output, you must multiply the input current corresponded in the table by 1.5.
- ☑ For installation in the United States, branch circuit protection must be provided in accordance with the National Electrical Code (NEC) and any applicable local codes. Use UL classified fuses to fulfill this requirement.
- ☑ For installation in Canada, branch circuit protection must be provided in accordance with Canadian Electrical Code and any applicable provincial codes. Use UL classified fuses to fulfill this requirement.

Model	Voltage/ one-phase (three-phase)	Current Input / Output (Maximum)		AC Input Terminal Fuse [A]	Brake Fuses (Terminal B1&B2) [A]
		Normal Duty	Heavy Duty		
VFD2A8MS21MNSXX VFD2A8MS21MFSXX	230V / one-phase	6.7 A / 3.2 A	5.9 A / 2.8 A	12.8	HINODE 1000GH-16UL
Class T JJS-15					
VFD4A8MS21MNSXX VFD4A8MS21MFSXX		10.5 A / 5.0 A	10.1 A / 4.8 A	20	HINODE 1000GH-16UL
Class T JJS-20					
VFD7A5MS21MNSXX VFD7A5MS21MFSXX	17.9 A / 8.5 A	15.8 A / 7.5 A	34	HINODE 1000GH-16UL	
Class T JJS-35					
VFD11AMS21MNSXX VFD11AMS21MFSXX	26.3 A / 12.5 A	23.1 A / 11.0 A	50	HINODE 1000GH-16UL	
Class T JJS-50					
VFD1A6MS23MNSXX	230V / three-phase	2.2 A / 1.8 A	1.9 A / 1.6 A	7.2	HINODE 1000GH-16UL
Class T JJS-10					
VFD2A8MS23MNSXX		3.8 A / 3.2 A	3.4 A / 2.8 A	12.8	HINODE 1000GH-16UL
Class T JJS-15					
VFD4A8MS23MNSXX		6.0 A / 5.0 A	5.8 A / 4.8 A	20	HINODE 1000GH-16UL
Class T JJS-20					
VFD7A5MS23MNSXX		9.6 A / 8.0 A	9.0 A / 7.5 A	32	HINODE 1000GH-16UL
Class T JJS-35					
VFD11AMS23MNSXX	15.0 A / 12.5 A	13.2 A / 11.0 A	50	HINODE 1000GH-16UL	
Class T JJS-50					
VFD17AMS23MNSXX	23.4 A / 19.5 A	20.4 A / 17.0 A	78	HINODE 1000GH-32UL	
Class T JJS-80					
VFD25AMS23MNSXX	32.4 A / 27.0 A	30.0 A / 25.0 A	59.4	HINODE 1000GH-40UL	
Class T JJS-60					
VFD1A5MS43MNSXX VFD1A5MS43MFSXX	460V / three-phase	2.5 A / 1.8 A	2.1 A / 1.5 A	7.2	HINODE 1000GH-16UL
Class T JJS-10					
VFD2A7MS43MNSXX VFD2A7MS43MFSXX		4.2 A / 3.0 A	3.7 A / 2.7 A	12	HINODE 1000GH-16UL
Class T JJS-15					
VFD4A2MS43MNSXX VFD4A2MS43MFSXX	6.4 A / 4.6 A	5.8 A / 4.2 A	18.4	HINODE 1000GH-16UL	
Class T JJS-20					

Model	Voltage/ one-phase (three-phase)	Current Input / Output (Maximum)		AC Input Terminal Fuse [A]	Brake Fuses (Terminal B1&B2) [A]
		Normal Duty	Heavy Duty		
VFD5A5MS43MNSXX VFD5A5MS43MFSXX		7.2 A / 6.5 A	6.1 A / 5.5 A	26	HINODE 1000GH-16UL
Class T JJS-25					
VFD9A0MS43MNSXX VFD9A0MS43MFSXX		11.6 A / 10.5 A	9.9 A / 9.0 A	31.5	HINODE 1000GH-16UL
Class T JJS-35					
VFD13AMS43MNSXX VFD13AMS43MFSXX		17.3 A / 15.7 A	14.3 A / 13.0 A	34.54	HINODE 1000GH-25UL
Class T JJS-35					
VFD17AMS43MNSXX VFD17AMS43MFSXX		22.6 A / 20.5 A	18.7 A / 17.0 A	45.1	HINODE 1000GH-32UL
Class T JJS-45					

7-4 AC/DC Reactor

AC Input Reactor (IP Level: IP00)

Installing an AC reactor on the input side of an AC motor drive can increase line impedance, improve the power factor, reduce input current, and reduce interference generated from the motor drive. It also reduces momentary voltage surges or abnormal current spikes. For example, when the main power capacity is higher than 500 kVA, or when using a switching capacitor bank, momentary voltage and current spikes may damage the AC motor drive's internal circuit. An AC reactor on the input side of the AC motor drive protects it by suppressing surges.

Installation

Install an AC input reactor in series between the main power and three input phases R / L1, S / L2, T / L3, as shown in the figure below:

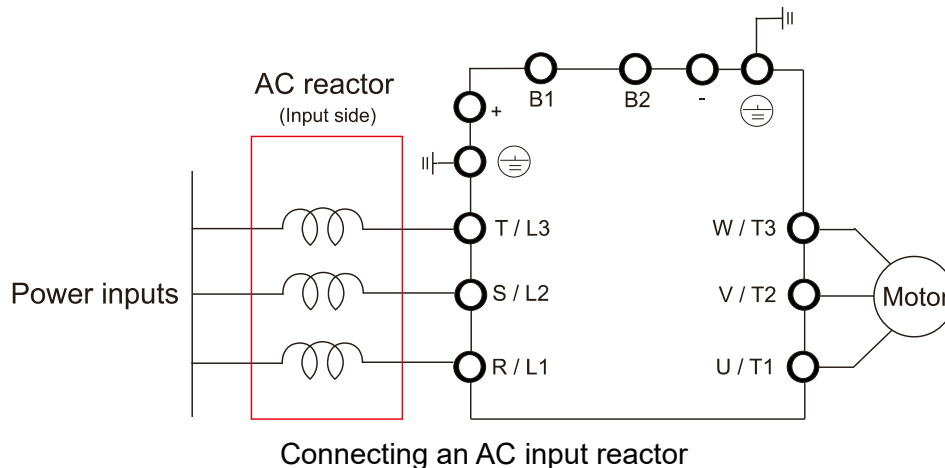

AC Output Reactor (IP Level: IP00)

When using drives in long wiring output application, ground fault (GFF), over-current (OC) and motor over-voltage (OV) often occur. GFF and OC cause errors due to the drive's self-protective mechanism; over-voltage damages motor insulation.

The excessive length of the output wires makes the grounded stray capacitance too large, increase the three-phase output common mode current, and the reflected wave of the long wires makes the motor dv/dt and the motor terminal voltage too high. Thus, installing a reactor on the drive's output side can increase the high-frequency impedance to reduce the dv/dt and terminal voltage to protect the motor.

Installation

Install an AC output reactor on the output side of the drive, as shown in the figure below:

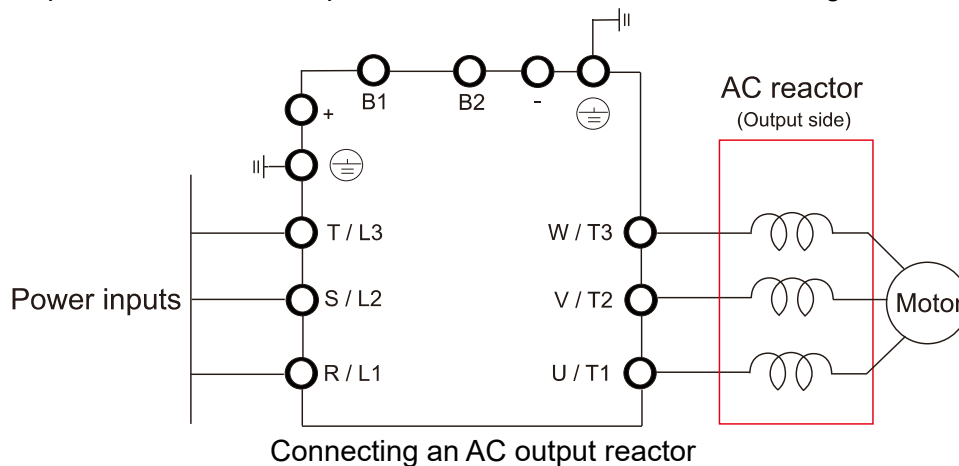

DC Reactor (IP Level: IP00)

A DC reactor can also improve the power factor, reduce input current, and reduce interference generated from the motor drive. A DC reactor stabilizes the DC BUS voltage. Compared to an AC input reactor, the advantages are smaller size, lower price, and lower voltage drop (lower power dissipation).

Installation

Install the DC reactor between terminals DC/+1 and +2/B1. Remove the jumper, as shown in the figure below, before installing the DC reactor.

Input: one-phase / three-phase power

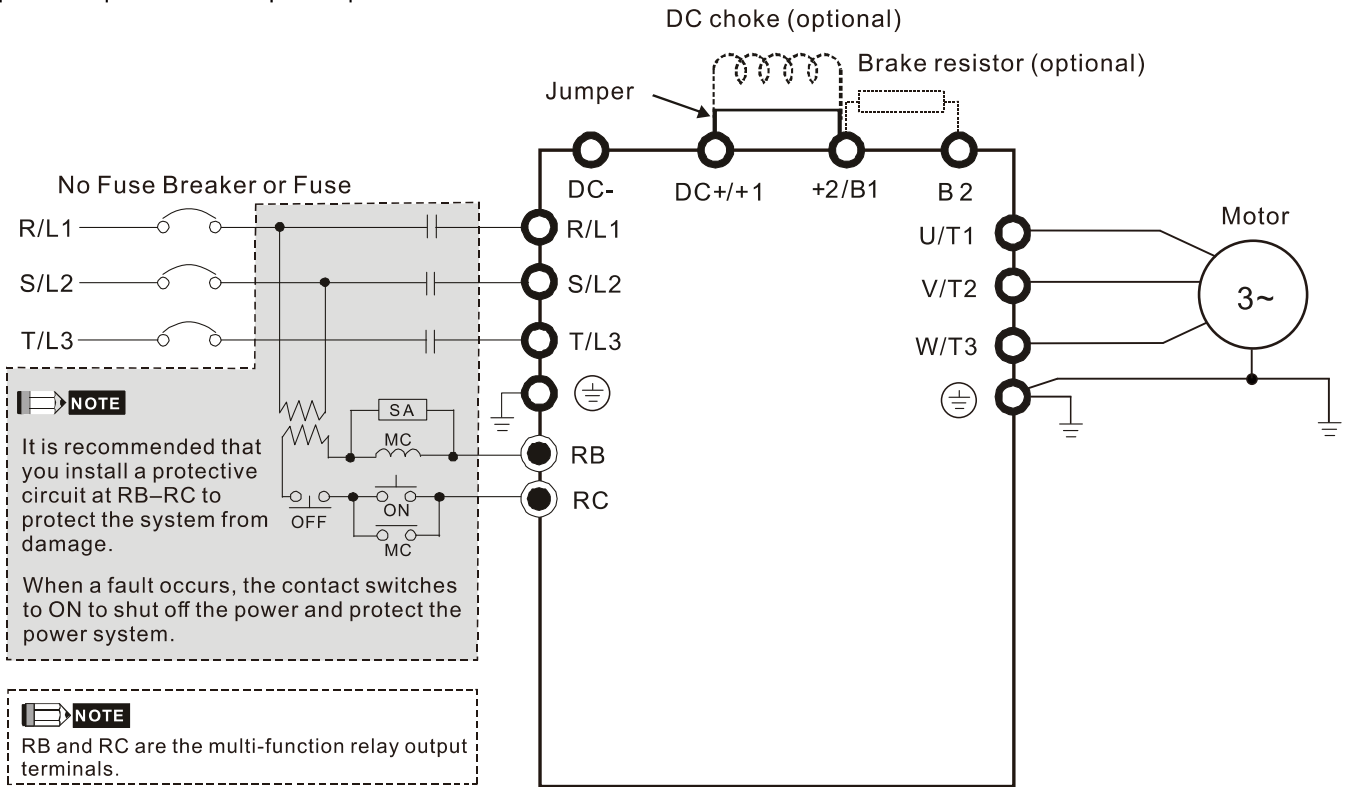

Wiring of DC reactor

230V, 50–60 Hz / One-Phase - Normal Duty

Model	Rated Current ND / HD [Arms]	Saturation ND / HD Current [Arms]	AC Input / Output Reactor Inductance [mH]	AC Input Reactor Delta Part #	AC Output Reactor Delta Part #	DC Reactor Inductance [mH]	DC Reactor Delta Part #
VFD2A8MS21MNSAA VFD2A8MS21MFSAA	3.2	4.8	5.857	DR005D0585	DR005L0254	5.857	DR005D0585
VFD5A0MS21MNSAA VFD5A0MS21MFSAA	5.2	7.8	3.66	DR008D0366	DR005L0254	3.66	DR008D0366
VFD7A5MS21MNSAA VFD7A5MS21MFSAA	8.5	12.75	2.662	DR011D0266	DR008L0159	2.662	DR011D0266
VFD11AMS21MNSAA VFD11AMS21MFSAA	12.5	18.75	1.722	DR017D0172	DR017LP746	1.722	DR017D0172

230V, 50–60 Hz / One-Phase - Heavy Duty

Model	Rated Current ND / HD [Arms]	Saturation ND / HD Current [Arms]	AC Input / Output Reactor Inductance [mH]	AC Input Reactor Delta Part #	AC Output Reactor Delta Part #	DC Reactor Inductance [mH]	DC Reactor Delta Part #
VFD2A8MS21MNSAA VFD2A8MS21MFSAA	2.8	5.6	5.857	DR005D0585	DR005L0254	5.857	DR005D0585
VFD4A8MS21MNSAA VFD4A8MS21MFSAA	4.8	9.6	3.66	DR008D0366	DR005L0254	3.66	DR008D0366
VFD7A5MS21MNSAA VFD7A5MS21MFSAA	7.5	15.0	2.662	DR011D0266	DR008L0159	2.662	DR011D0266
VFD11AMS21MNSAA VFD11AMS21MFSAA	11.0	22.0	1.722	DR017D0172	DR011L0115	1.722	DR017D0172

230V, 50–60 Hz / Three-Phase - Normal Duty

Model	Rated Current ND / HD [Arms]	Saturation ND / HD Current [Arms]	AC Input / Output Reactor Inductance [mH]	AC Input Reactor Delta Part #	AC Output Reactor Delta Part #	DC Reactor Inductance [mH]	DC Reactor Delta Part #
VFD2A8MS23MNSAA	3.2	4.8	2.536	DR005A0254	DR005L0254	5.857	DR005D0585
VFD4A8MS23MNSAA	5.0	7.5	2.536	DR005A0254	DR005L0254	5.857	DR005D0585
VFD7A5MS23MNSAA	8.0	12.0	1.585	DR008A0159	DR008L0159	3.66	DR008D0366
VFD11AMS23MNSAA	12.5	18.75	0.746	DR017AP746	DR017LP746	2.662	DR011D0266
VFD17AMS23MNSAA	19.5	29.25	0.507	DR025AP507	DR025LP507	1.722	DR017D0172
VFD25AMS23MNSAA	27.0	40.5	0.32	DR033AP320	DR033LP320	1.172	DR025D0117

230V, 50–60 Hz / Three-Phase - Heavy Duty

Model	Rated Current ND / HD [Arms]	Saturation ND / HD Current [Arms]	AC Input / Output Reactor Inductance [mH]	AC Input Reactor Delta Part #	AC Output Reactor Delta Part #	DC Reactor Inductance [mH]	DC Reactor Delta Part #
VFD2A8MS23MNSAA	2.8	5.6	2.536	DR005A0254	DR005L0254	5.857	DR005D0585
VFD4A8MS23MNSAA	4.8	9.6	2.536	DR005A0254	DR005L0254	5.857	DR005D0585
VFD7A5MS23MNSAA	7.5	15.0	1.585	DR008A0159	DR008L0159	3.66	DR008D0366
VFD11AMS23MNSAA	11.0	22.0	1.152	DR011A0115	DR011L0115	2.662	DR011D0266
VFD17AMS23MNSAA	17.0	34.0	0.746	DR017AP746	DR017LP746	1.722	DR017D0172
VFD25AMS23MNSAA	25.0	50.0	0.507	DR025AP507	DR025LP507	1.172	DR025D0117

460V, 50–60 Hz / Three-Phase - Normal Duty

Model	Rated Current ND / HD [Arms]	Saturation ND / HD Current [Arms]	AC Input / Output Reactor Inductance [mH]	AC Input Reactor Delta Part #	AC Output Reactor Delta Part #	DC Reactor Inductance [mH]	DC Reactor Delta Part #
VFD1A5MS43MNSAA VFD1A5MS43MFSAA	1.8	2.7	8.102	DR003A0810	DR003L0810	18.709	DR003D1870
VFD2A7MS43MNSAA VFD2A7MS43MFSAA	3.0	4.5	6.077	DR004A0607	DR004L0607	18.709	DR003D1870
VFD4A2MS43MFSAA VFD4A2MS43MNSAA	4.6	6.9	4.05	DR006A0405	DR006L0405	14.031	DR004D1403
VFD5A5MS43MFSAA VFD5A5MS43MNSAA	6.5	9.75	2.7	DR009A0270	DR009L0270	9.355	DR006D0935
VFD9A0MS43MFSAA VFD9A0MS43MNSAA	10.5	15.75	2.315	DR010A0231	DR010L0231	5.345	DR010D0534
VFD13AMS43MFSAA VFD13AMS43MNSAA	15.7	23.55	1.174	DR018A0117	DR012L0202	3.119	DR018D0311
VFD17AMS43MFSAA VFD17AMS43MNSAA	20.5	30.75	0.881	DR024AP881	DR018L0117	3.119	DR018D0311

460V, 50–60 Hz / Three-Phase - Heavy Duty

Model	Rated Current ND / HD [Arms]	Saturation ND / HD Current [Arms]	AC Input / Output Reactor Inductance [mH]	AC Input Reactor Delta Part #	AC Output Reactor Delta Part #	DC Reactor Inductance [mH]	DC Reactor Delta Part #
VFD1A5MS43MNSAA VFD1A5MS43MFSAA	1.5	3.0	8.102	DR003A0810	DR003L0810	18.709	DR003D1870
VFD2A7MS43MNSAA VFD2A7MS43MFSAA	2.7	5.4	8.102	DR003A0810	DR003L0810	18.709	DR003D1870
VFD4A2MS43MFSAA VFD4A2MS43MNSAA	4.2	8.4	6.077	DR004A0607	DR004L0607	14.031	DR004D1403
VFD5A5MS43MNSAA VFD5A5MS43MFSAA	5.5	11.0	4.05	DR006A0405	DR006L0405	9.355	DR006D0935
VFD9A0MS43MNSAA VFD9A0MS43MFSAA	9.0	18.0	2.7	DR009A0270	DR009L0270	6.236	DR009D0623
VFD13AMS43MNSAA VFD13AMS43MFSAA	13.0	26.0	1.174	DR018A0117	DR010L0231	4.677	DR012D0467
VFD17AMS43MNSAA VFD17AMS43MFSAA	17.0	34.0	1.174	DR018A0117	DR012L0202	3.119	DR018D0311

AC input reactor dimensions and specifications

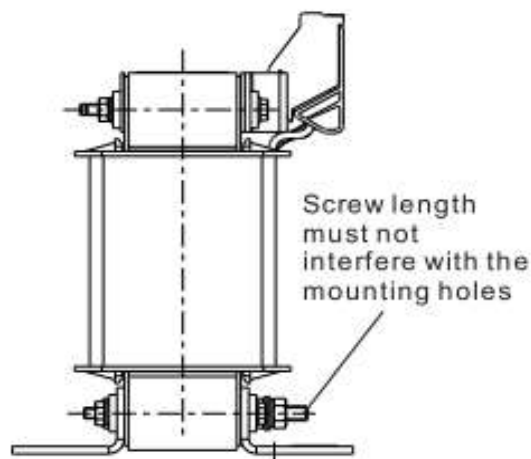
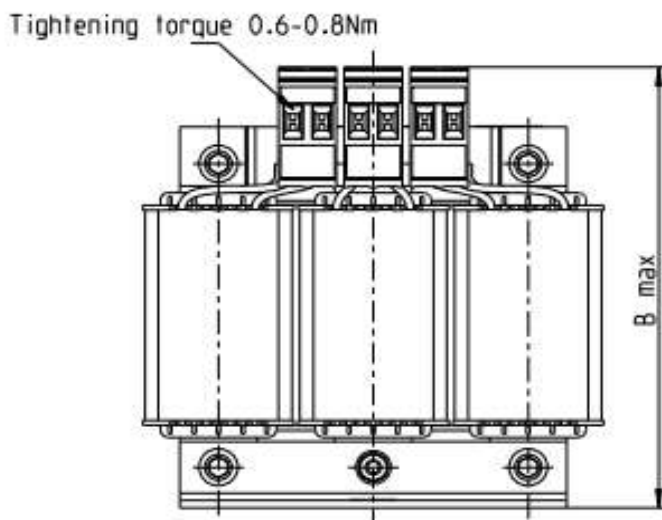
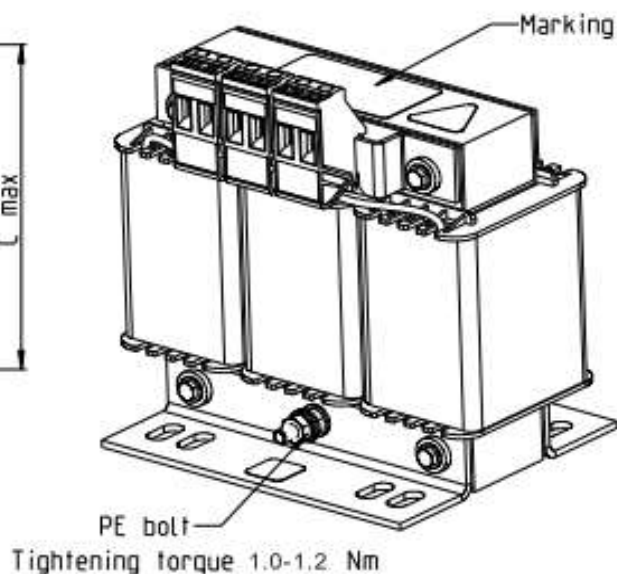
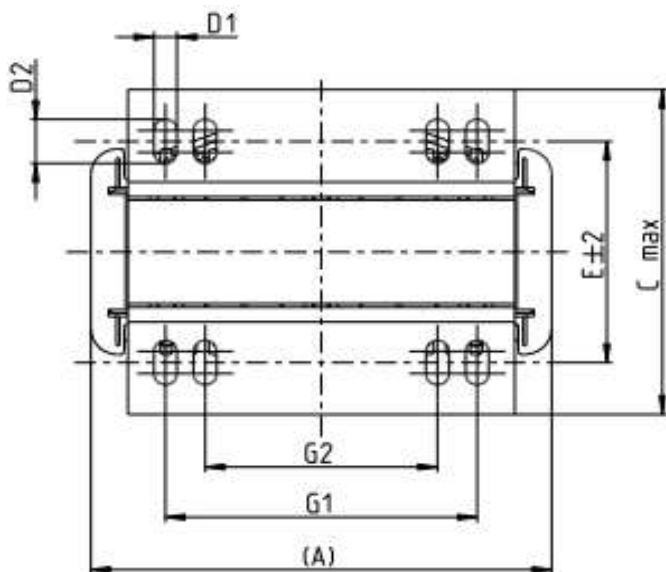

Screw Location	Torque
Terminal	5.32–7.09 kg-cm / [6.12–8.16 lb-in.] / [0.6–0.8 Nm]
PE bolt	8.86–10.63 kg-cm / [10.2–12.24 lb-in.] / [1.0–1.2 Nm]

Unit: mm

AC Input Reactor Delta Part #	A	B	C	D1*D2	E	G1	G2	PE D
DR005A0254	96	100	60	6*9	42	60	40	M4
DR008A0159	120	120	88	6*12	60	80.5	60	M4
DR011A0115	120	120	88	6*12	60	80.5	60	M4
DR017AP746	120	120	93	6*12	65	80.5	60	M4
DR025AP507	150	150	112	6*12	88	107	75	M4
DR033AP320	150	150	112	6*12	88	107	75	M4

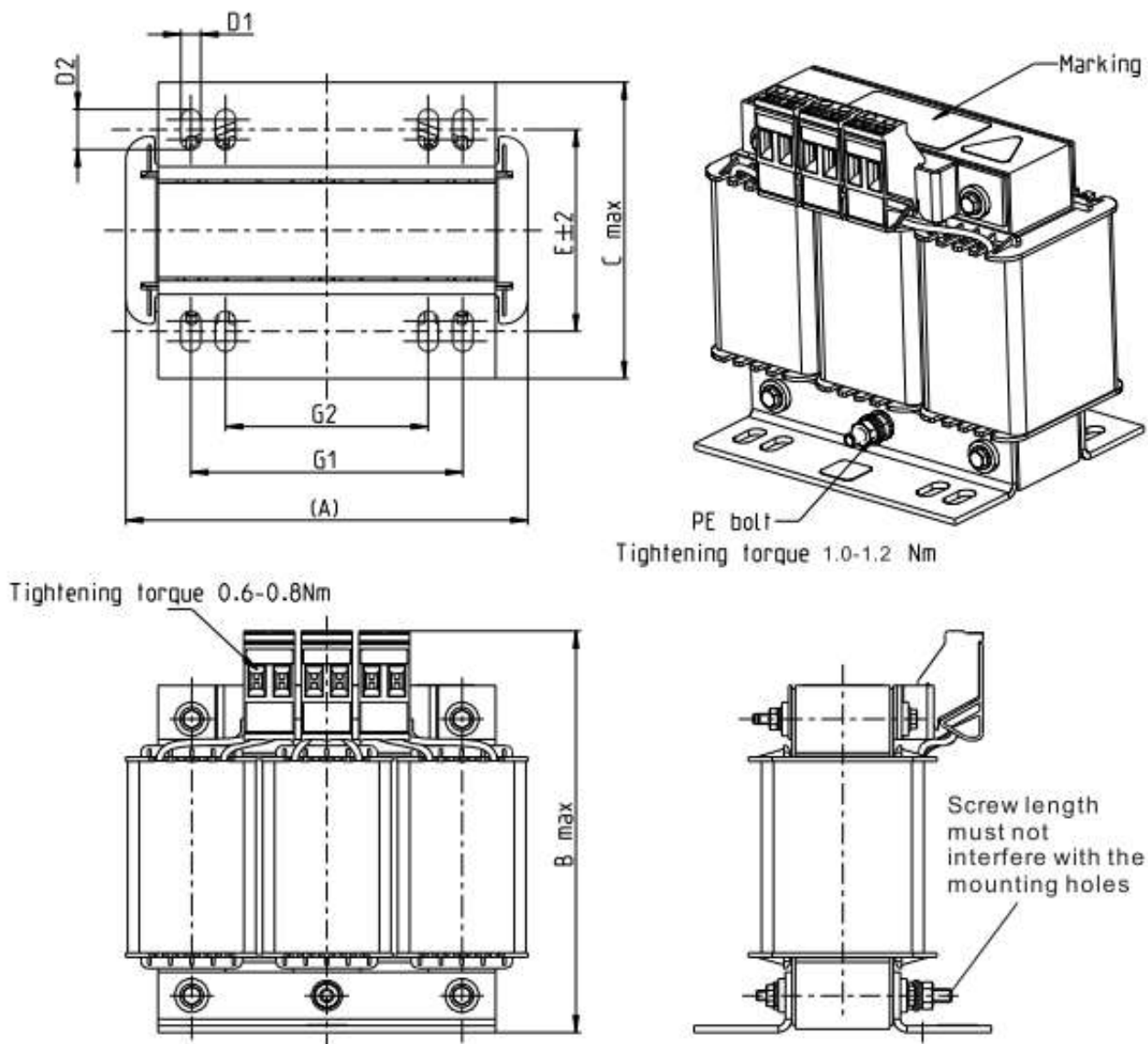

Screw Location	Torque
Terminal	5.32–7.09 kg-cm / [6.12–8.16 lb-in.] / [0.6–0.8 Nm]
PE bolt	8.86–10.63 kg-cm / [10.2–12.24 lb-in.] / [1.0–1.2 Nm]

Unit: mm

AC Input Reactor Delta Part #	A	B	C	D1*D2	E	G1	G2	PE D
DR003A0810	96	100	60	6*9	42	60	40	M4
DR004A0607	120	120	88	6*12	60	80.5	60	M4
DR006A0405	120	120	88	6*12	60	805	60	M4
DR009A0270	150	150	88	6*12	74	107	75	M4
DR010A0231	150	150	112	6*12	88	107	75	M4
DR012A0202	150	150	112	6*12	88	107	75	M4
DR018A0117	150	155	112	6*12	88	107	75	M4
DR024AP881	150	155	112	6*12	88	107	75	M4

AC output reactor dimensions and specifications

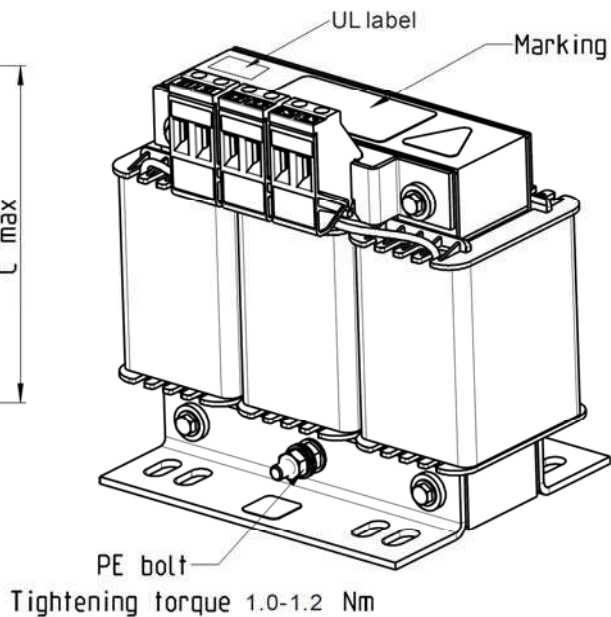
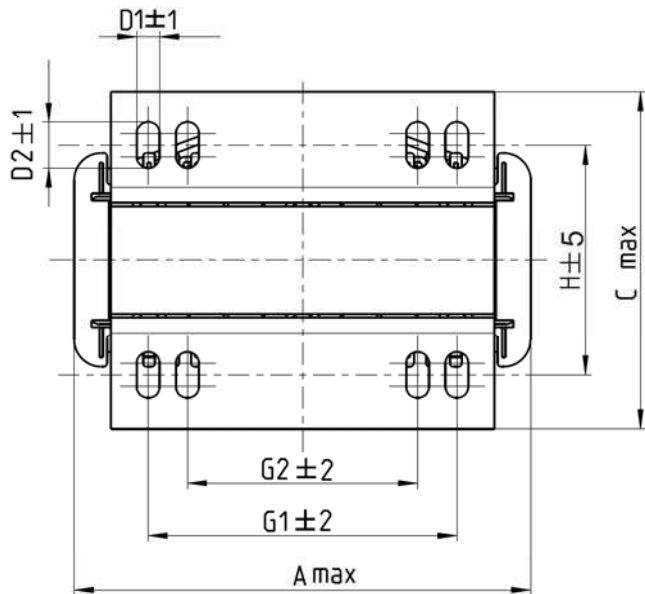

Tightening torque 0.6-0.8Nm

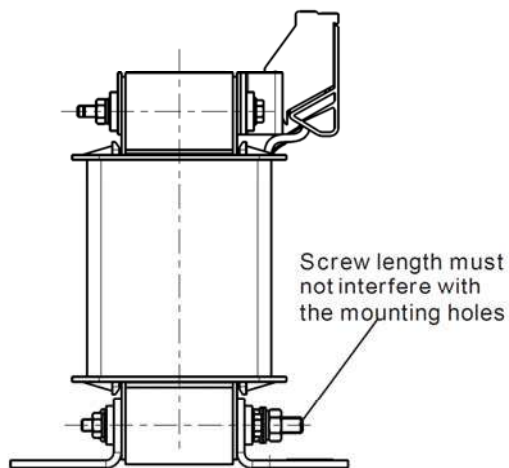
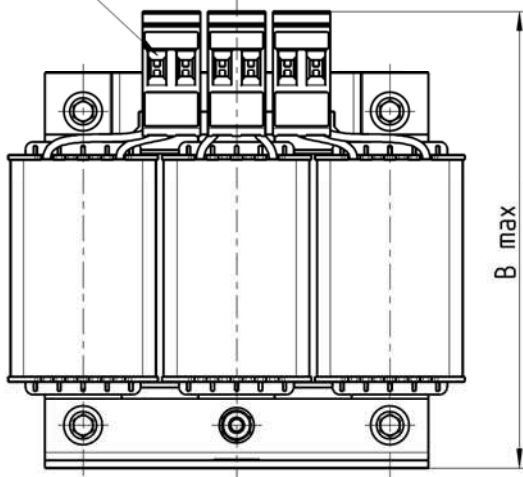

Unit: mm

AC Input Reactor Delta Part #	A	B	C	D1*D2	E	G1	G2	PE D
DR005L0254	96	110	70	6*9	42	60	40	M4
DR008L0159	120	135	96	6*12	60	80.5	60	M4
DR011L0115	120	135	96	6*12	60	80.5	60	M4
DR017LP746	120	135	105	6*12	65	80.5	60	M4
DR025LP507	150	160	120	6*12	88	107	75	M4
DR033LP320	150	160	120	6*12	88	107	75	M4

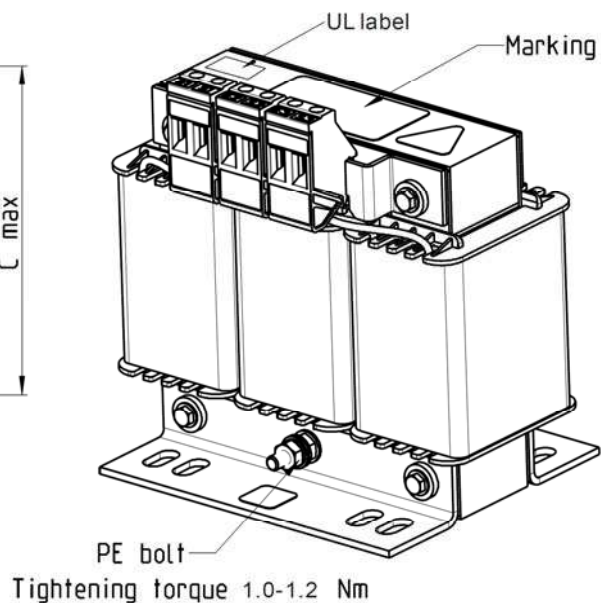
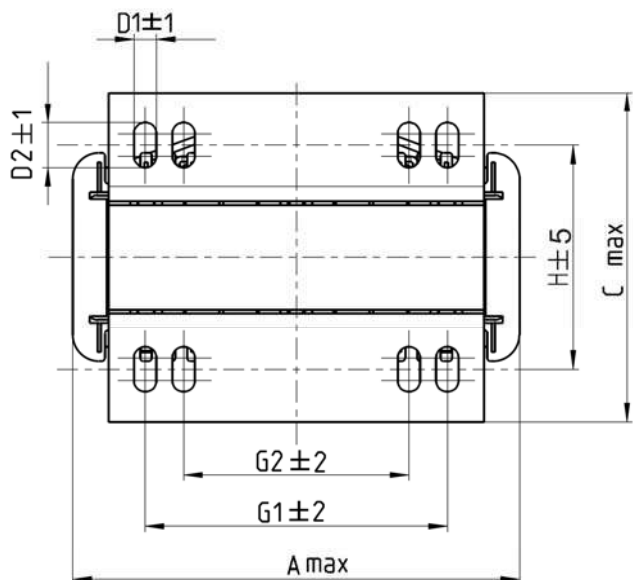

Tightening torque 0.6-0.8Nm

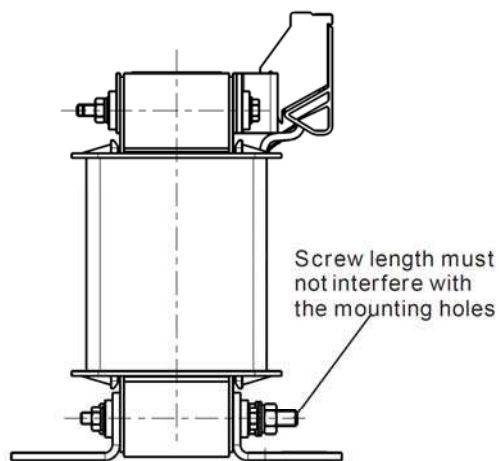
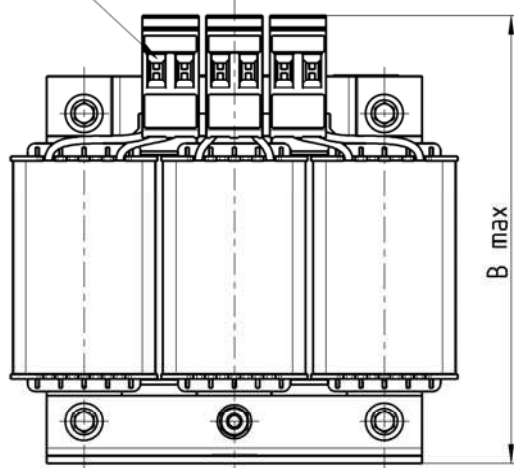

Unit: mm

AC Input Reactor Delta Part #	A	B	C	D1*D2	E	G1	G2	PE D
DR003L0810	96	115	65	6*9	42	60	40	M4
DR004L0607	120	135	95	6*12	60	80.5	60	M4
DR006L0405	120	135	95	6*12	60	80.5	60	M4
DR009L0270	150	160	100	6*12	74	107	75	M4
DR010L0231	150	160	115	6*12	88	107	75	M4
DR012L0202	150	160	115	6*12	88	107	75	M4
DR018L0117	150	160	115	6*12	88	107	75	M4

DC reactor dimensions and specifications

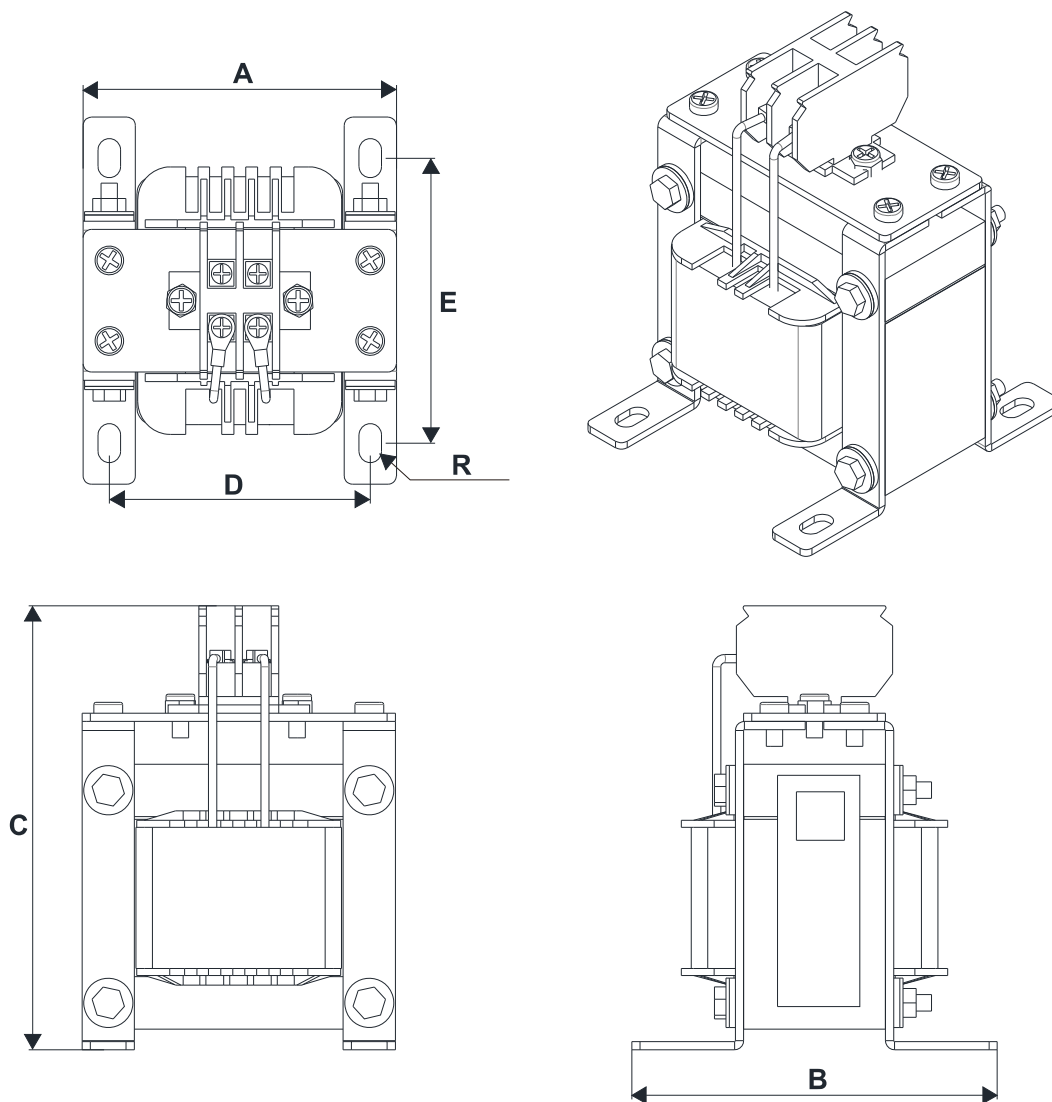

DC Reactor Delta Part #	Rated Current [Arms]	Saturation Current [Arms]	DC Reactor Inductance [mH]	A [mm]	B [mm]	C [mm]	D [mm]	E [mm]	R [mm]
DR005D0585	5	8.64	5.857	79	78	112	64±2	56±2	9.5*5.5
DR008D0366	8	12.78	3.660	79	78	112	64±2	56±2	9.5*5.5
DR011D0266	11	18	2.662	79	92	112	64±2	69.5±2	9.5*5.5
DR017D0172	17	28.8	1.722	79	112	112	64±2	89.5±2	9.5*5.5
DR025D0117	25	43.2	1.172	99	105	128	79±2	82.5±2	9.5*5.5
DR003D1870	3	5.22	18.709	79	78	112	64±2	56±2	9.5*5.5
DR004D1403	4	6.84	14.031	79	92	112	64±2	69.5±2	9.5*5.5
DR006D0935	6	10.26	9.355	79	92	112	64±2	69.5±2	9.5*5.5
DR009D0623	9	14.58	6.236	79	112	112	64±2	89.5±2	9.5*5.5
DR010D0534	10.5	17.1	5.345	99	93	128	79±2	70±2	9.5*5.5
DR012D0467	12	19.8	4.677	99	105	128	79±2	82.5±2	9.5*5.5
DR018D0311	18	30.6	3.119	117	110	144	95±2	87±2	10*6.5

Length of the Motor Cable

1. Leakage current affects the motor and remedies

Due to larger parasitic capacitances in longer motor cables, longer cables increase the leakage current. This can activate the over-current protection and display the incorrect current. In the worst case, it can damage the drive.

If more than one motor is connected to the AC motor drive, the total motor cable length is the sum of the cable length from AC motor drive to each motor.

For 460V series AC motor drives, when an overload relay is installed between the drive and the motor to protect the motor from overheating, the connecting cable must be shorter than 50 m.

However, the overload relay could still malfunction. To prevent this, install an AC output reactor (optional) to the drive and/or lower the carrier frequency setting (Pr.00-17).

2. Surge voltage affects the motor and remedies

When a PWM signal from an AC motor drive drives the motor, the motor terminals can easily experience surge voltages (dv/dt) due to IGBT switching and cable capacitance. When the motor cable is very long (especially for the 460V series), surge voltages (dv/dt) may reduce motor insulation quality. To prevent this situation, follow the rules listed below.

- a. Use a motor with enhanced insulation.
- b. Connect an output reactor (optional) to the output terminals of the AC motor drive.
- c. Reduce the motor cable length to the values in the table below.

The suggested motor shielded cable length in the following table complies with IEC 60034-17, which is suitable for motors with a rated voltage $\leq 500 V_{AC}$ and with an insulation level of $\geq 1.35 kV_{p-p}$

460V Three-phase Model	Without AC Reactor		With AC Reactor	
	Shielded Cable [meter]	Non-shielded Cable [meter]	Shielded Cable [meter]	Non-shielded Cable [meter]
VFD1A5MS43MNSAA VFD1A5MS43MFSAA	35	50	50	90
VFD2A7MS43MNSAA VFD2A7MS43MFSAA	35	50	50	90
VFD4A2MS43MNSAA VFD4A2MS43MFSAA	35	50	50	90
VFD5A5MS43MNSAA VFD5A5MS43MFSAA	50	75	75	115
VFD9A0MS43MNSAA VFD9A0MS43MFSAA	50	75	75	115
VFD13AMS43MNSAA VFD13AMS43MFSAA	50	75	75	115
VFD17AMS43MNSAA VFD17AMS43MFSAA	100	150	150	225

7-5 Zero Phase Reactors (IP Level: IP20)

You can also suppress interference by installing a zero phase reactor at the main input or the motor output of the drive, depending on the location of the interference. Delta provides two types of zero phase reactors to solve interference problems.

A. Casing with mechanical fixed part

This solution is for the main input/motor output side and can withstand higher loading, and be used at higher frequencies. You can get higher impedance by increasing the number of turns.

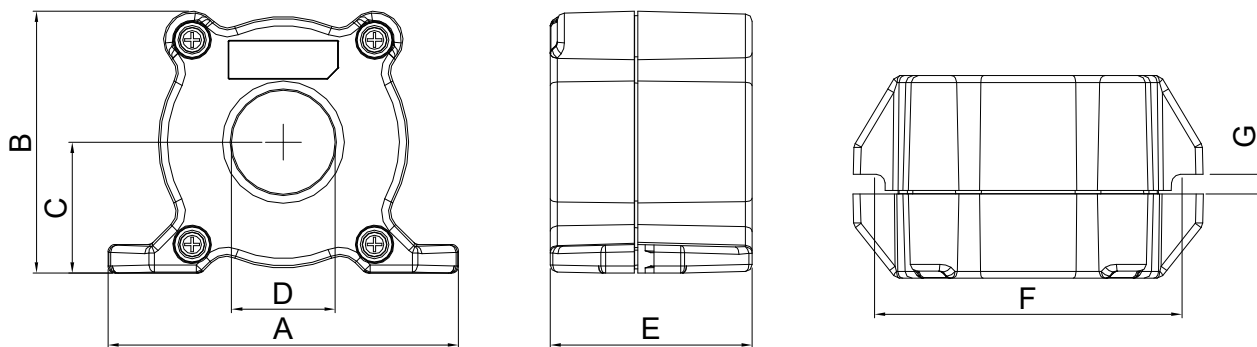

Unit: mm

Model	A	B	C	D	E	F	G(Ø)	To use w/
RF008X00A	99	73	36.5	29	56.5	86	5.5	Motor cable

B. Casing without mechanical fixed part

This solution has higher performance: high initial magnetic permeability, high saturation induction density, low iron loss and perfect temperature characteristic. If the zero phase reactor does not need to be fixed mechanically, use this solution.

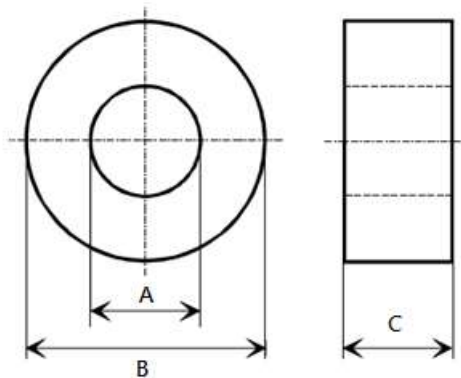

Unit: mm

Model	A	B	C
T60006L2040W453	22.5	43.1	18.5
T60006L2050W565	36.3	53.5	23.4

Installation

During installation, pass the cable through at least one zero phase reactor. Use a suitable cable type (insulation class and wire section) so that the cable passes easily through the zero phase reactor. Do not pass the grounding cable through the zero phase reactor; only pass the motor wire through the zero phase reactor.

With longer motor cables the zero-phase reactor can effectively reduce interference at the motor output. Install the zero-phase reactor as close to the output of the drive as possible. Figure A shows the installation diagram for a single turn zero-phase reactor. If the wire diameter allows several turns, Figure B shows the installation of a multi-turn zero-phase reactor. The more turns, the better the noise suppression effect.

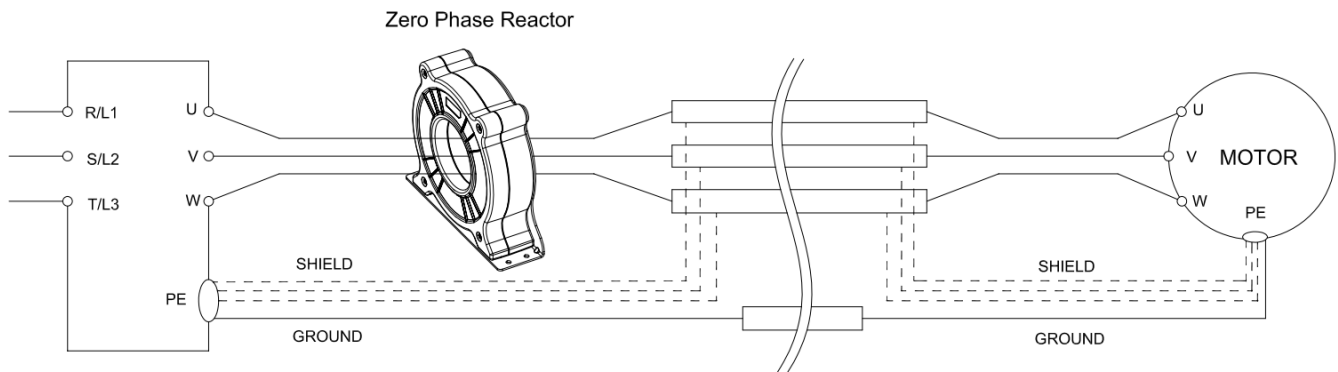

Figure A: Single turn wiring diagram for shielding wire with a zero phase reactor

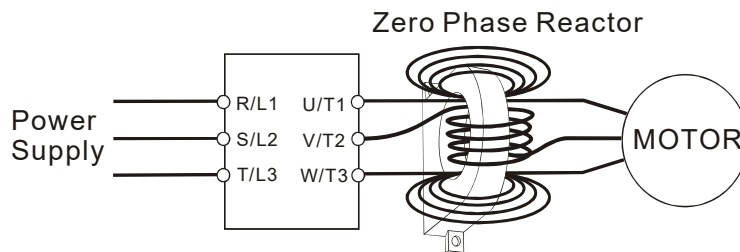

Figure B: Multi-turn zero phase reactor

Installation notes

Install the zero phase reactor at the drive's output terminal (U/T1, V/T2, W/T3). After the zero phase reactor is installed, it reduces the electromagnetic radiation and load stress emitted by the wiring of the frequency converter. The number of zero phase reactors required for the drive depends on the wiring length and the drive voltage.

The normal operating temperature of the zero phase reactor should be lower than 85 °C (176 °F). However, when the zero phase reactor is saturated, its temperature may exceed 85 °C (176 °F). In this case, increase the number of zero phase reactors to avoid saturation. The following are reasons that might cause saturation of the zero phase reactors: the drive wiring is too long; the drive has several sets of loads; the wiring is in parallel; or the drive uses high capacitance wiring. If the temperature of the zero phase reactor exceeds 85 °C (176 °F) during the operation of the drive, increase the number of zero phase reactors.

Recommended maximum wiring gauge when installing zero phase reactor

Model # of Zero Phase Reactor	Max. Wire Gauge or LUG width	Max. Wire Gauge AWG*	
		75°C	90°C
RF008X00A	13 mm	3 AWG	1 AWG
T600006L2040W453	11 mm	6 AWG	6 AWG
T600006L2050W565	16 mm	1 AWG	1/0 AWG

* Pass the zero phase reactor only through the power inputs (R/L1, S/L2, T/L3) or motor outputs (U/T1, V/T2, W/T3), not the grounding PE.

Refer to the figures below for the common output wiring methods.

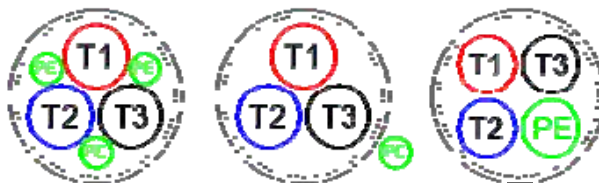

Zero Phase Reactor for Signal Cable

To solve interference problems between signal cables and electric devices, install a zero phase reactor on signal cable. Install it on the signal cable which is the source of the interference to suppress the noise for a better signal. The model names and dimensions are listed in the table below.

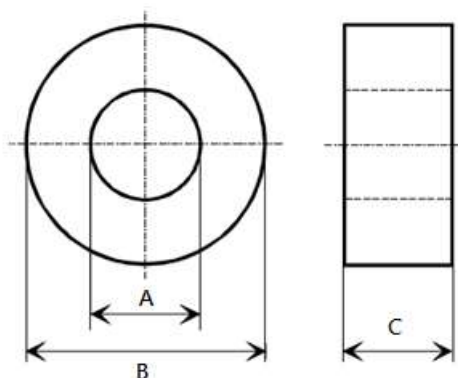

Unit: mm

Model	A	B	C
T60004L2016W620	10.7	17.8	8.0
T60004L2025W622	17.5	27.3	12.3

7-6 EMC Filter (IP Level: IP20)

Using an EMC filter enhances the machine and surrounding environment's EMC capabilities to meet with EMC requirements and reduces problems caused by EMC. If you use a model without a built-in EMC filter, it is recommended that you buy an optional EMC filter. Some models may need to work with zero phase reactors to comply with EMC standards. The table and figure below show the recommended models for EMC filters and zero phase reactors, installation methods, and the maximum motor cable length.

Frame	Model #	Input Current [A]	Filter Model #	Recommended Model of Zero Phase Reactor		Conducted Emission			Radiated Emission			
						C1-motor cable length-30m		C2-motor cable length-100m		C2-motor cable length-100m		
						Position to Place Zero Phase Reactor						
						DELTA	V _{AC}	*1	*2	*3	N/A	*1
A	VFD2A8MS21MNSAA	8.3	EMF11AM21A	RF008X00A	T60006L2040W453		✓	✓	N/A		✓	✓
	VFD4A8MS21MNSAA	11.3	EMF11AM21A				✓	✓	N/A		✓	✓
	VFD7A5MS21MNSAA	18.5	EMF27AM21B					✓	N/A			✓
	VFD2A8MS23MNSAA	3.8	EMF10AM23A				✓	✓	N/A		✓	✓
	VFD4A8MS23MNSAA	6	EMF10AM23A				✓	✓	N/A		✓	✓
	VFD7A5MS23MNSAA	9.6	EMF10AM23A				✓	✓	N/A		✓	✓
	VFD1A5MS43MNSAA	2.5	EMF6A0M43A					✓	N/A			✓
	VFD2A7MS43MNSAA	4.2	EMF6A0M43A					✓	N/A			✓
	VFD4A2MS43MNSAA	6.4	EMF6A0M43A					✓	N/A			✓
	VFD5A5MS43MNSAA	7.2	EMF12AM43B						N/A			
B	VFD11AMS21MNSAA	27.5	EMF27AM21B				✓		N/A			✓
	VFD11AMS23MNSAA	15	EMF24AM23B			✓	✓	N/A		✓	✓	
	VFD17AMS23MNSAA	23.4	EMF24AM23B			✓	✓	N/A		✓	✓	
	VFD9A0MS43MNSAA	11.6	EMF12AM43B			✓	✓	N/A		✓	✓	
C	VFD25AMS23MNSAA	32.4	EMF33AM23B		T60006L2050W565	✓	✓		N/A	✓	✓	
	VFD13AMS43MNSAA	17.3	EMF23AM43B			✓	✓	✓	N/A	✓	✓	✓
	VFD17AMS43MNSAA	22.6	EMF23AM43B			✓	✓	✓	N/A	✓	✓	✓

Positions to install zero phase reactors:

- *1 Install on the cable between the power supply and the EMC filter.
- *2 Install on the cable between the EMC filter and the drive.
- *3 Install on the cable between the drive and the motor.

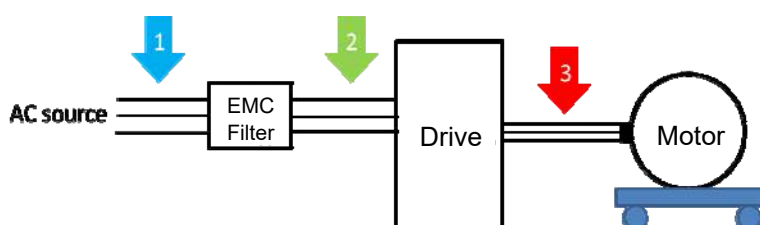

EMC Filter Dimension

EMF11AM21A
 EMF10AM23A
 EMF6A0M43A

Screw	Torque
M5 * 2	16–20 kg-cm / [13.9–17.3 lb-in.] / [1.56–1.96 Nm]
M4 * 2	14–16 kg-cm / [12.2–13.8 lb-in.] / [1.38–1.56 Nm]

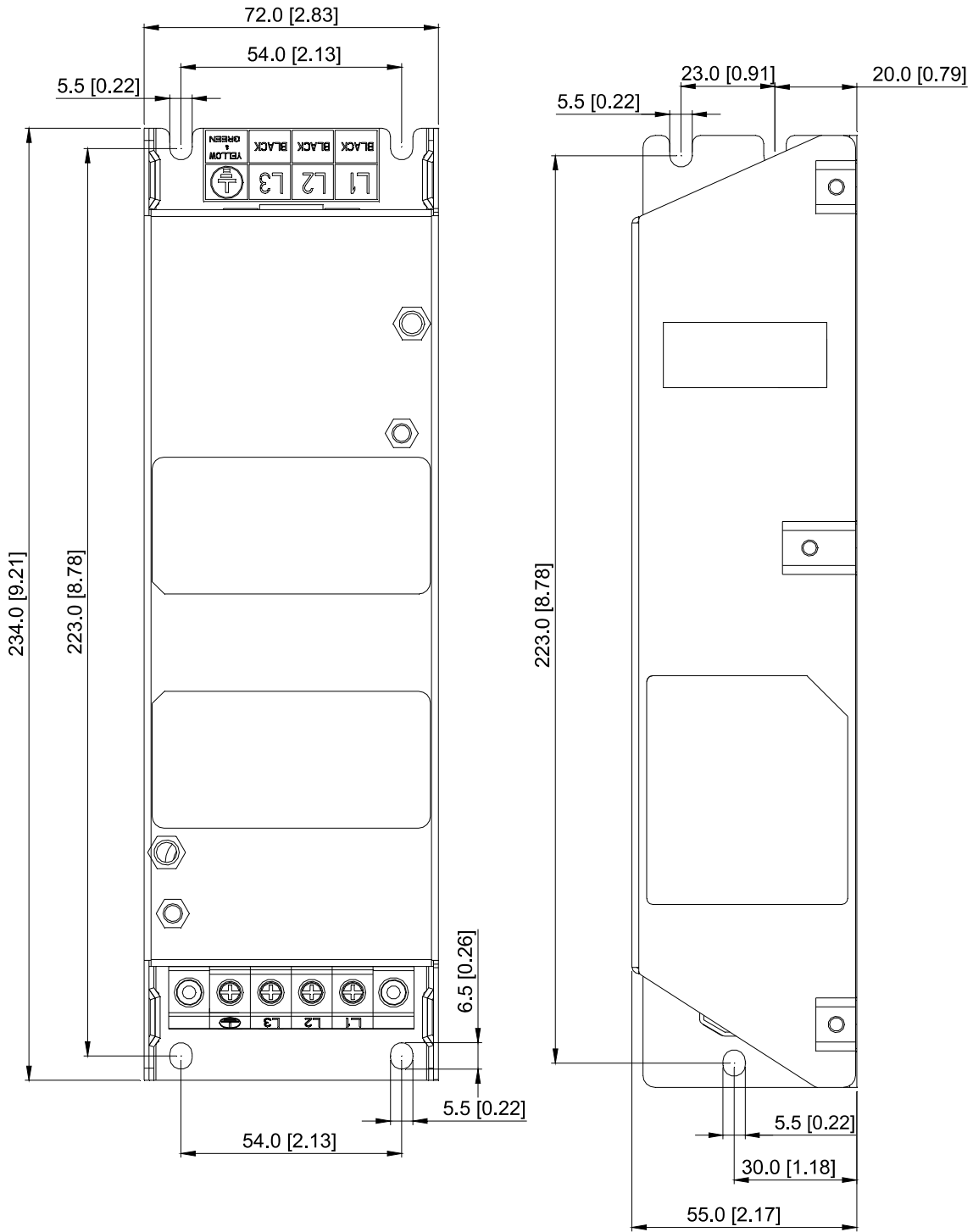

Unit: mm
 [inch]

EMF27AM21B; EMF24AM23B

EMF33AM23B; EMF12AM43B

EMF23AM43B

Screw	Torque
M5 * 4	16–20 kg-cm / [13.9–17.3 lb-in.] / [1.56–1.96 Nm]

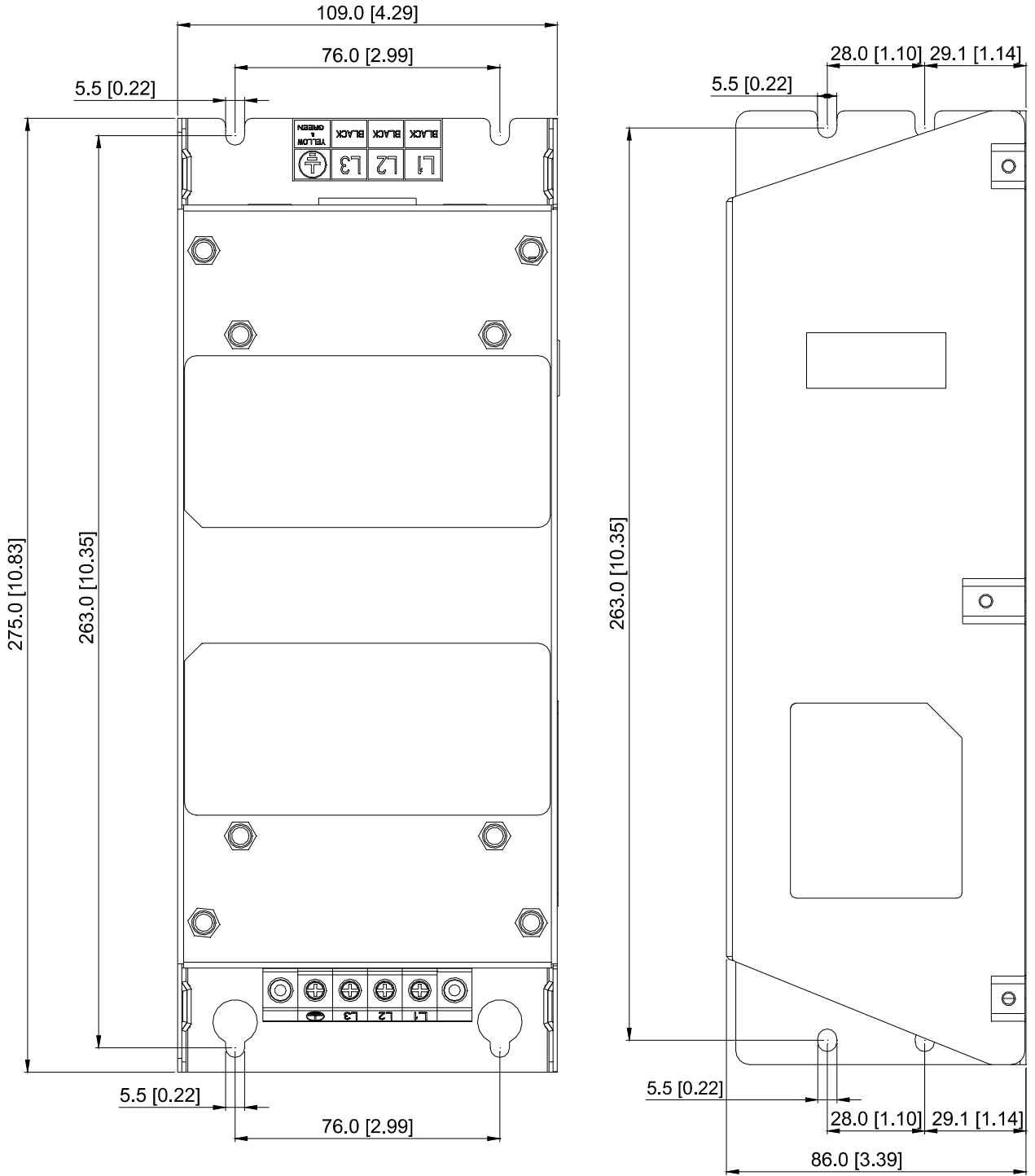

Unit: mm [inch]

7-7 EMC Shield Plate

7-7-1 Model Name and Appearance

EMC Shield Plate (for use with shielded cable)

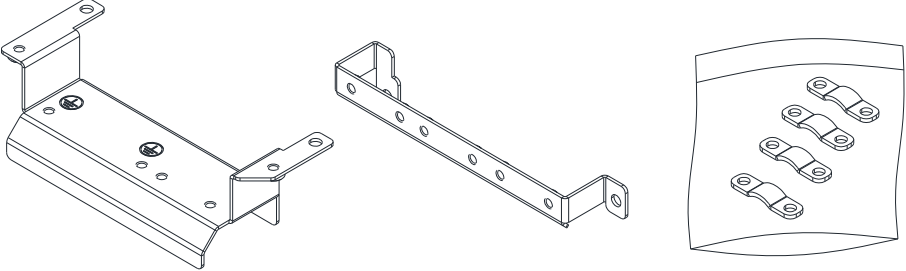
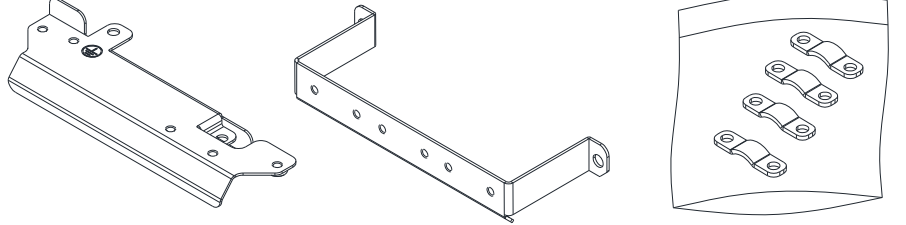
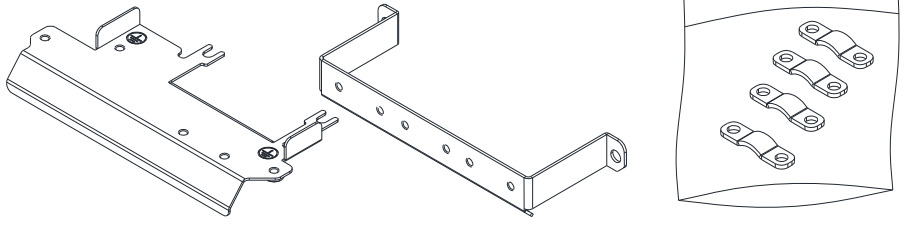
Frame	Model of EMC Shield Plate	Reference Figure
A	MKMX-EPA	
B	MKMX-EPB	
C	MKMX-EPC	

7-7-2 Installation

Frame A

Screw: M4

Torque value: 6–8 kg-cm / [5.2–6.9 lb-in.] / [0.59–0.78 Nm]

1. Loosen the ground screws on the right and left.

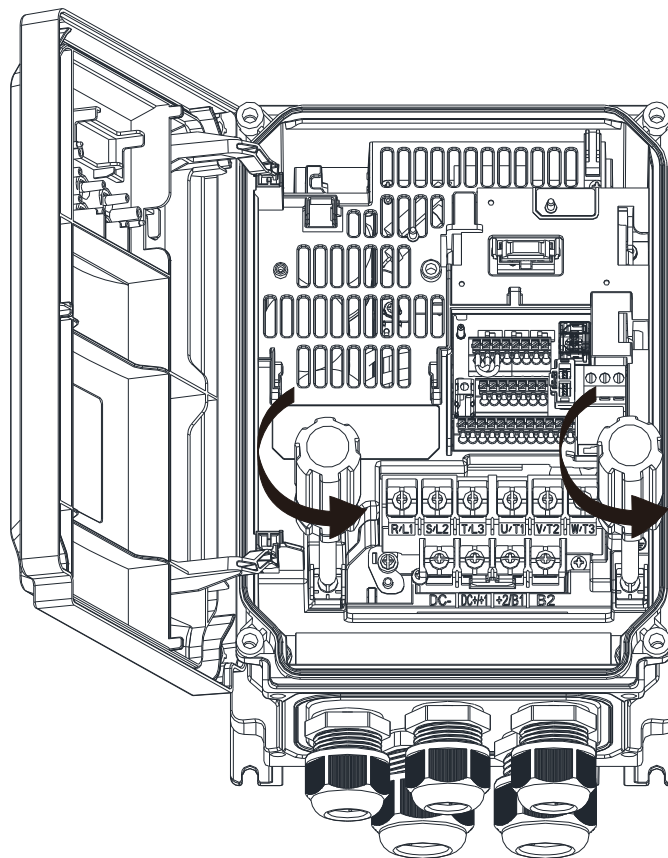

2. Put the first EMC shield plate into the drive, and then tighten the ground screws on the right and left again.

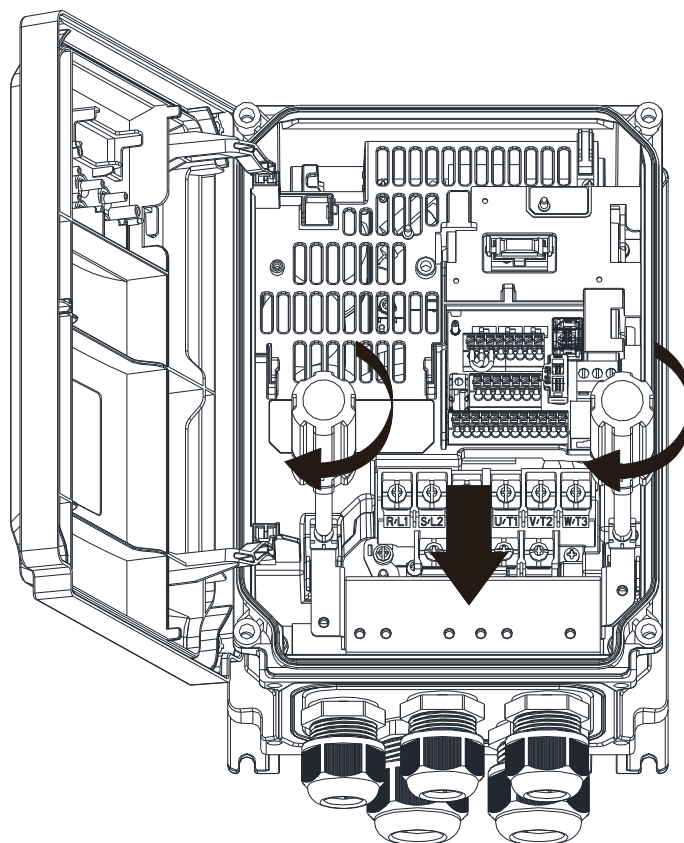

3. Before doing any wiring, strip part of the wire wraps, and then tighten the wires for output terminals on the EMC shield plate (clamps must be fixed on the shielding).

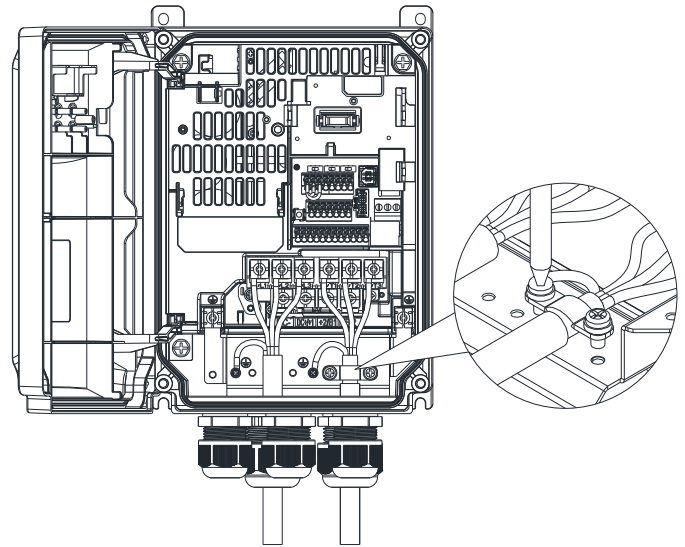

4. Install the second EMC shield plate on top of the first one.

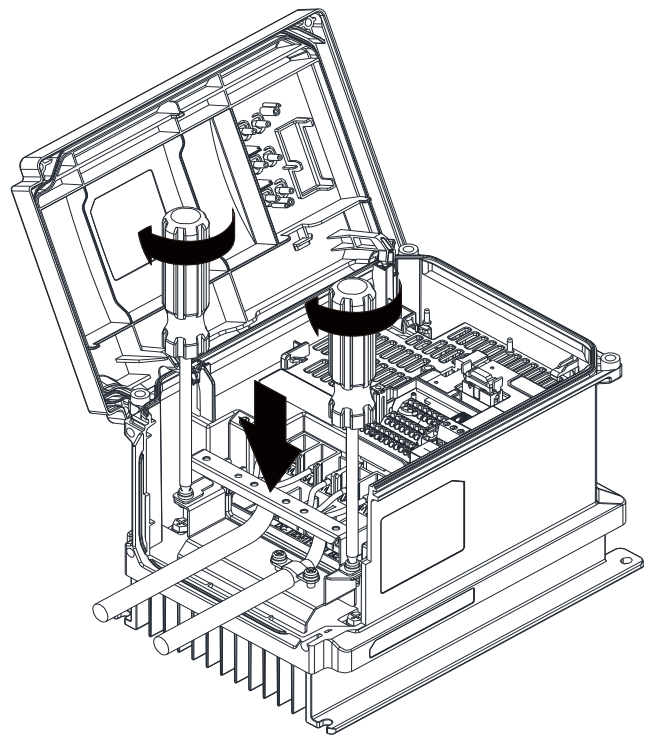

5. Tighten and fix the control wire with clamps.

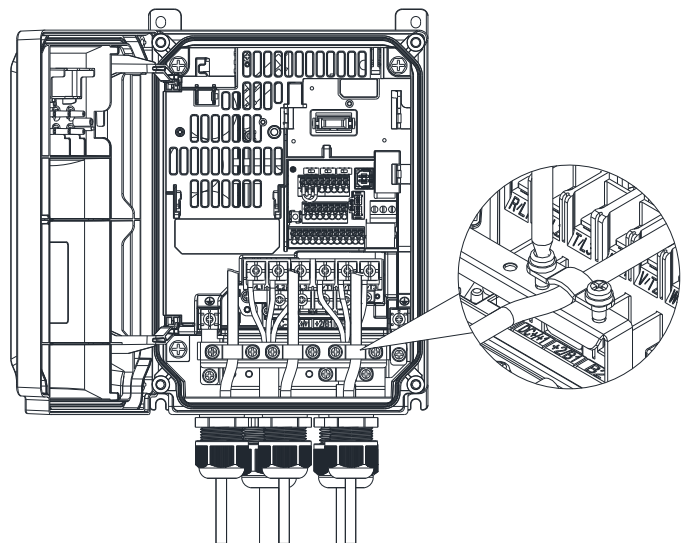

Frame B

Screw: M4

Torque value: 6–8 kg-cm / [5.2–6.9 lb-in.] / [0.59–0.78 Nm]

1. Loosen the ground screws on the left.

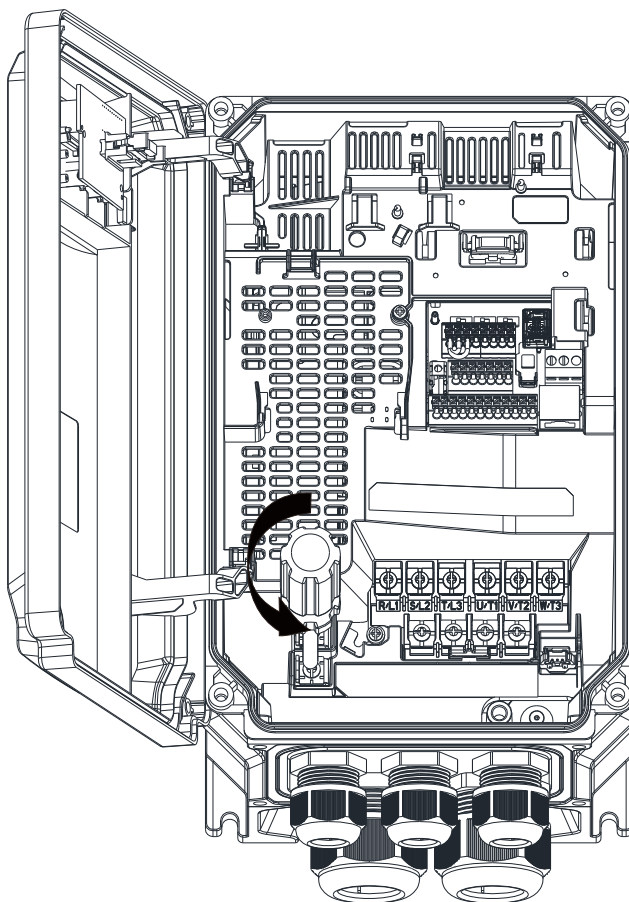

2. Put the first EMC shield plate into the drive, and then tighten the ground screws on the left and the fixing screw on the right.

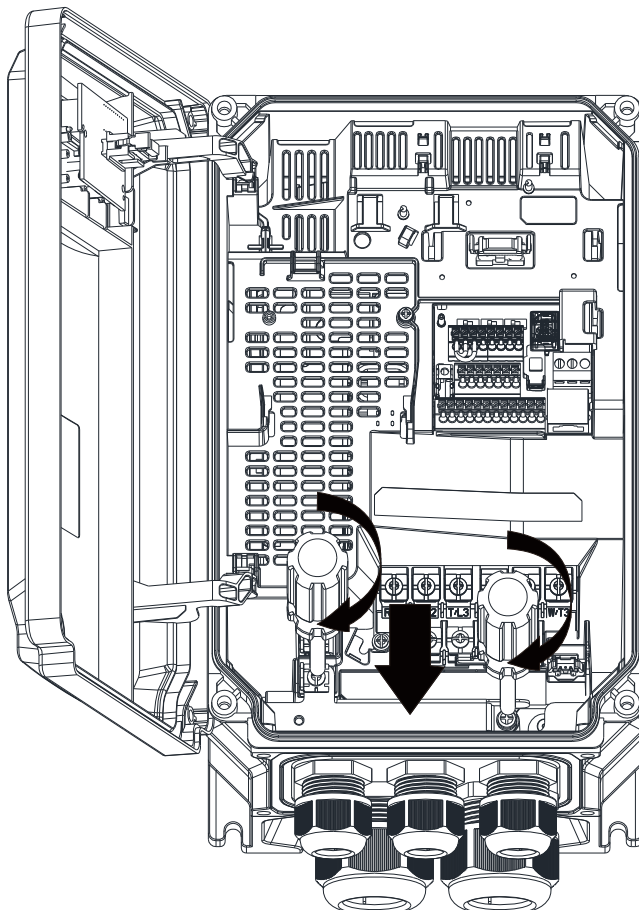

3. Before doing any wiring, strip part of the wire wraps, and then tighten the wires for output terminals on the EMC shield plate (clamps must be fixed on the shielding).

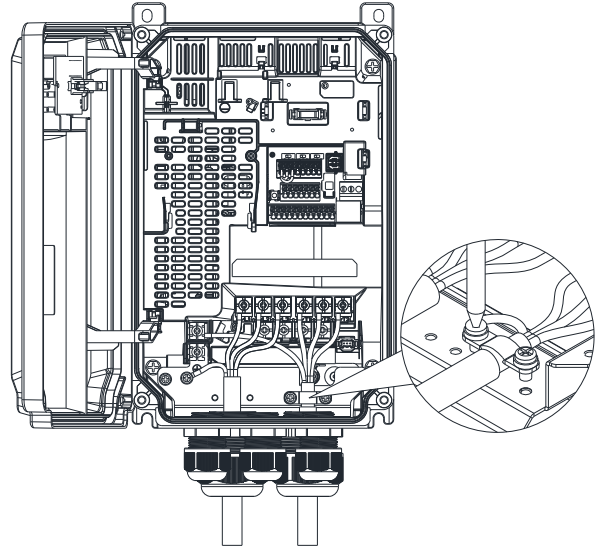

4. Install the second EMC shield plate on top of the first one.

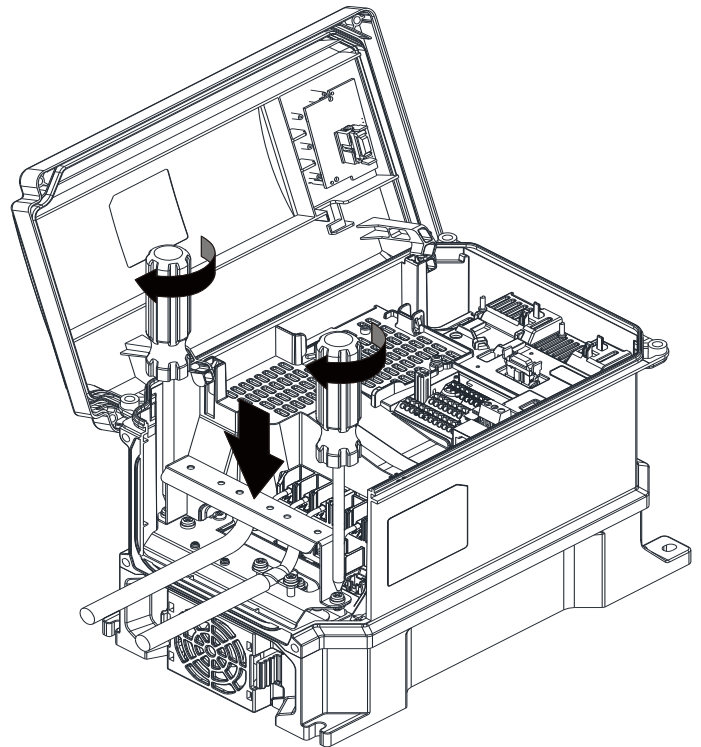

5. Tighten and fix the control wire with clamps.

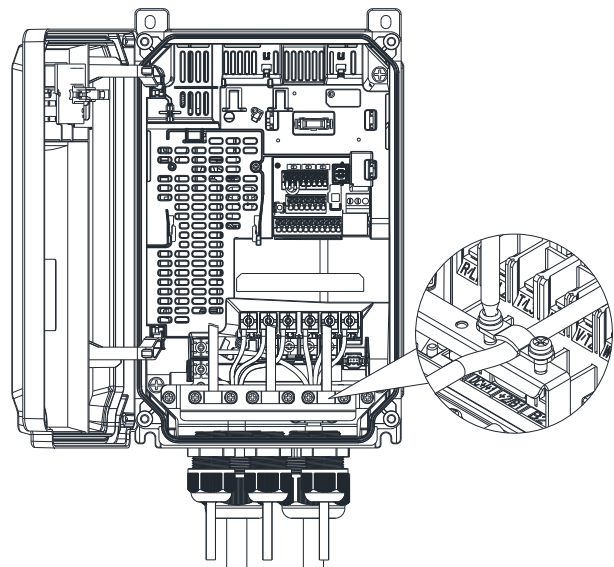

Frame C

Screw: M4

Torque value: 6–8 kg-cm / [5.2–6.9 lb-in.] / [0.59–0.78 Nm]

1. Loosen the ground screws on the right and left.

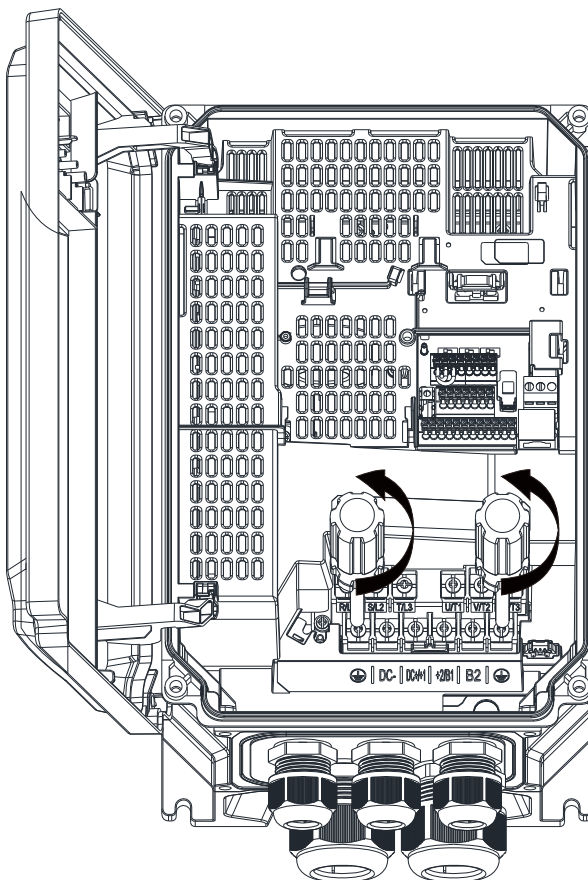

2. Put the first EMC shield plate into the drive, and then tighten the ground screws on the right and left again.

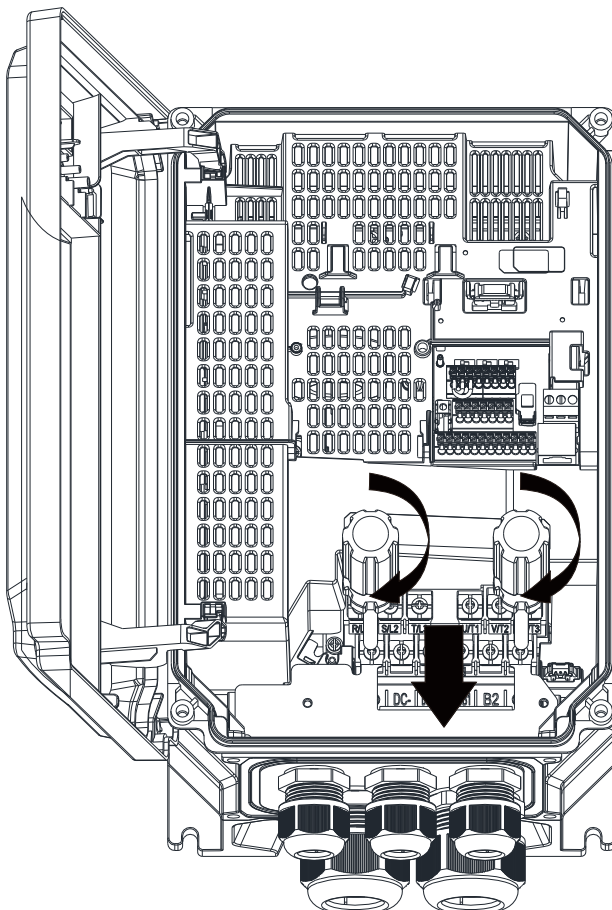

3. Before doing any wiring, strip part of the wire wraps, and then tighten the wires for output terminals on the EMC shield plate (clamps must be fixed on the shielding).

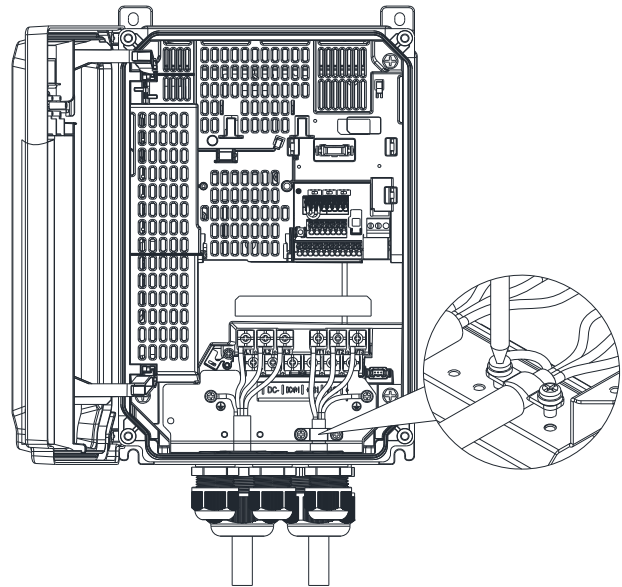

4. Install the second EMC shield plate on top of the first one.

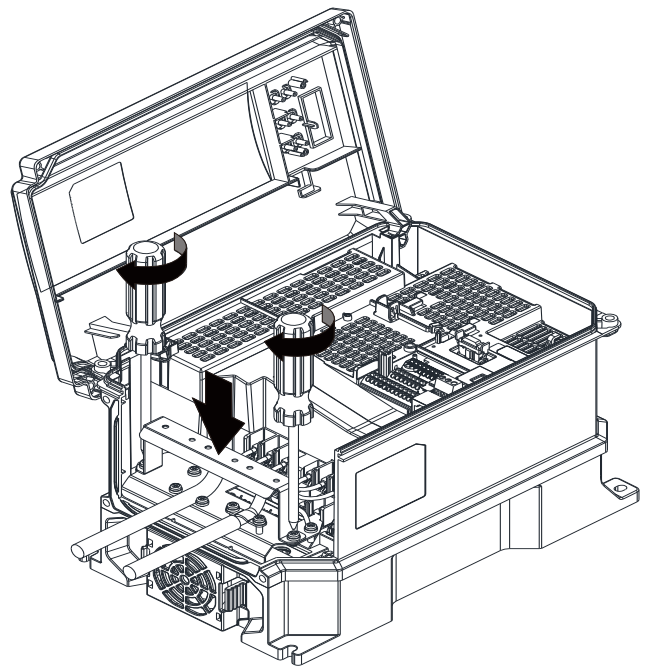

5. Tighten and fix the control wire with clamps.

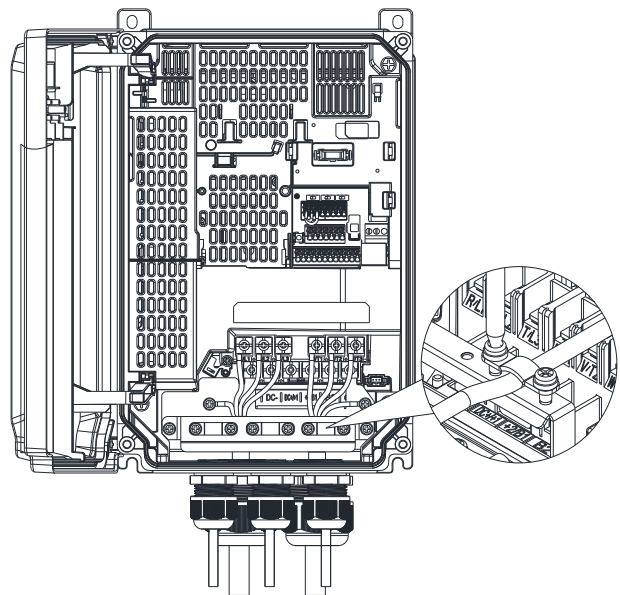

7-8 Capacitive Filter (IP Level: IP20)

The capacitive filter is a simple filter that supports basic filtering and noise interference reduction.

Installation

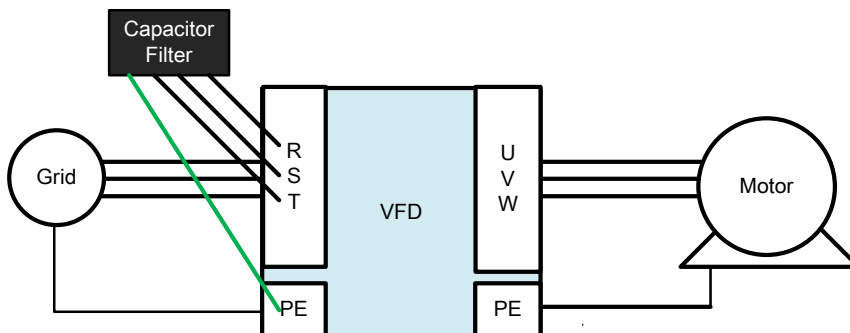

Specifications

Model	Capacitance	Temperature range
CXY101-43A	Cx: 1 μ F \pm 20 % Cy: 0.1 μ F \pm 20 %	-40–85°C

Dimensions CXY101-43A

Unit: mm [inch]

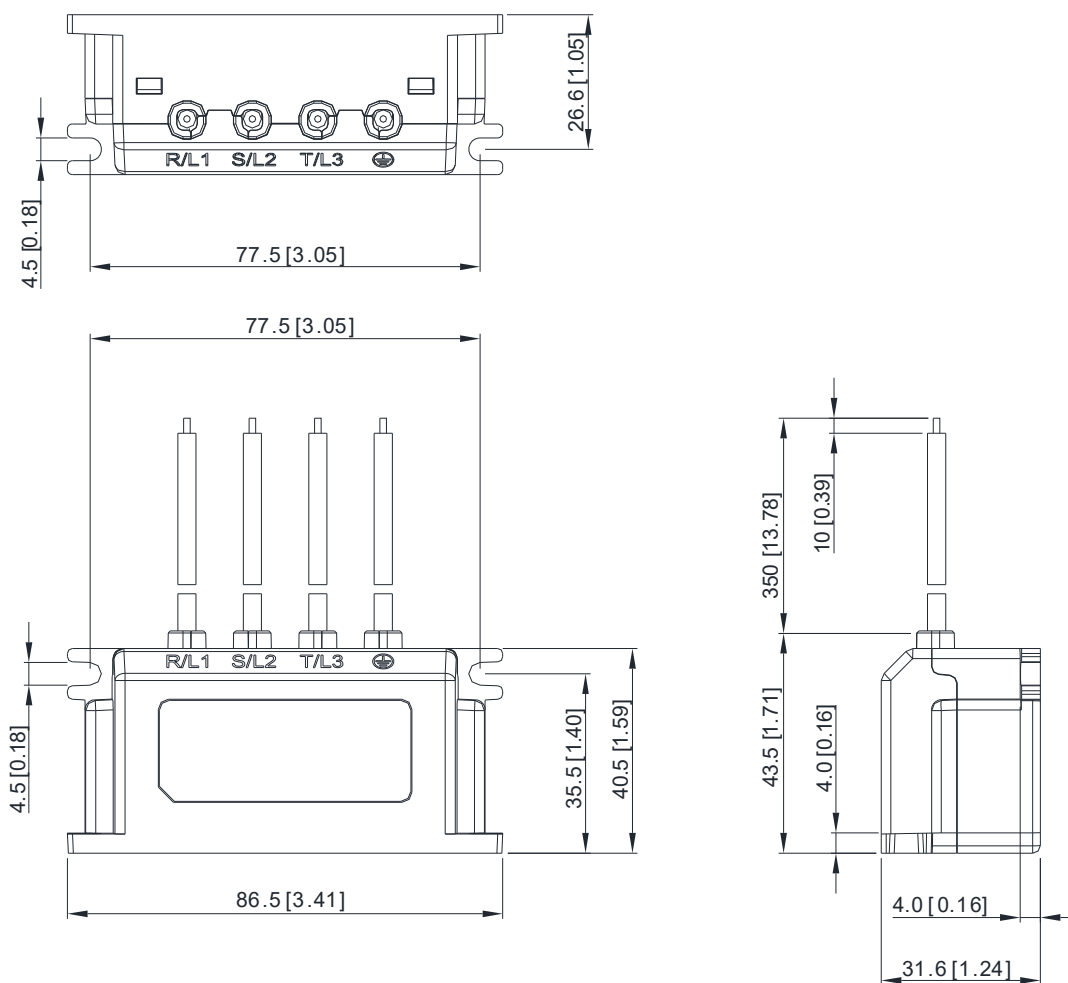

7-9 Fan Kit (IP Level: IP66)

7-9-1 Model Name and Appearance

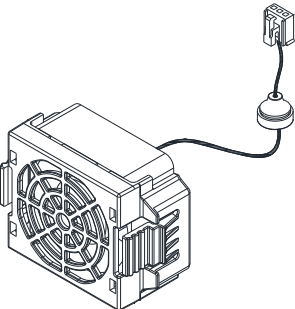
Frame	Fan Model	Fan Kit
B	MKMX-FKMB	
C	MKMX-FKMC	

7-9-2 Fan Change

Before changing the fan, remove the EMC shield plate if the drive installs it. The removing method is to follow the installation instructions described in Section 7-7-2 in reverse order, that is, from Step 5 to Step 1.

1. Unplug the fan connector.
2. Remove the fan cover from the drive.
3. Remove the rubber bushing from the hole of the casing.
4. The fan assembly method becomes from Step 3 to Step 1, in reverse order. Note: Verify that end A is correctly mounted and the petticoat of end B is everted after inserting the rubber bushing into the hole of the casing, as shown in the lower right figure.

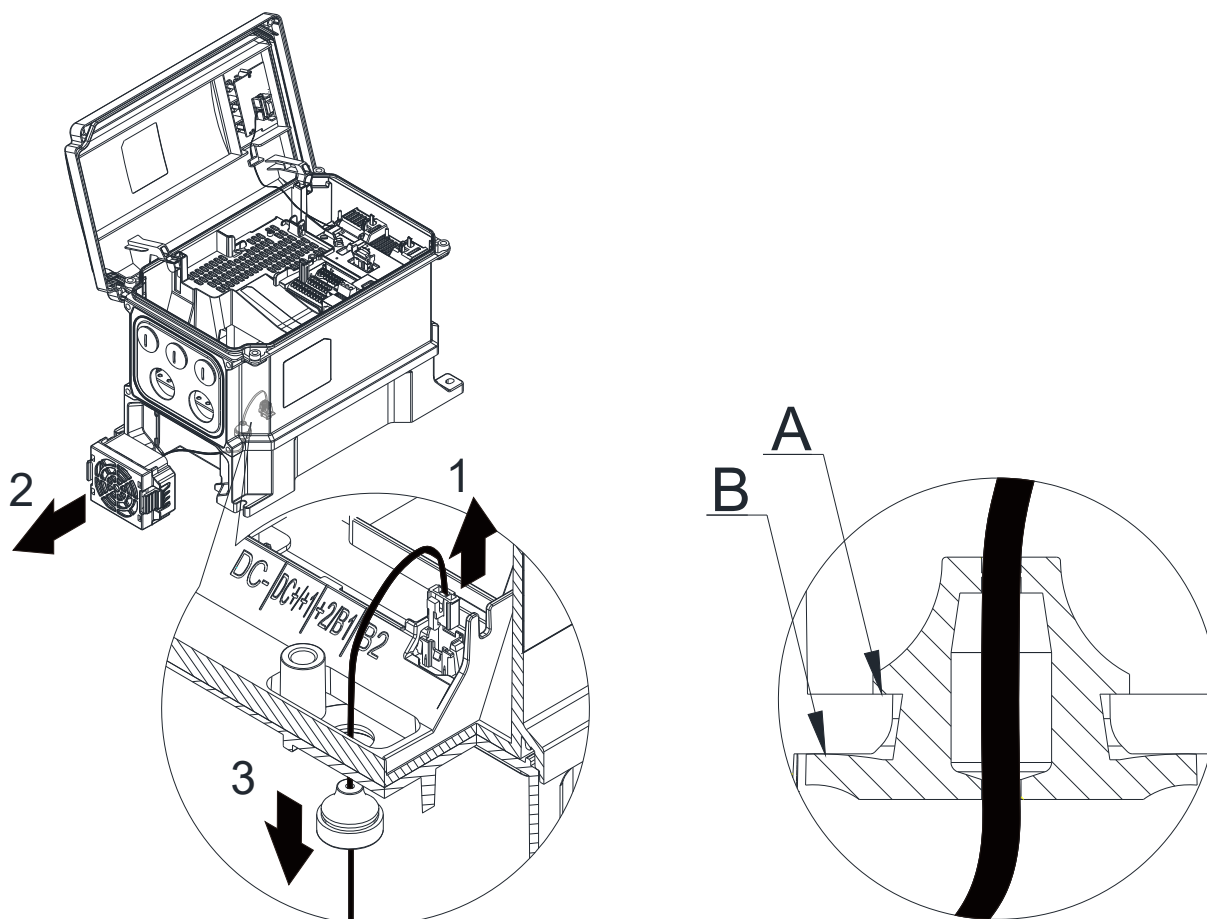

7-10 Main Switch (IP Level: IP66)

7-10-1 Appearance and Dimensions

MKMX-SWA (Applicable model: Frame A)

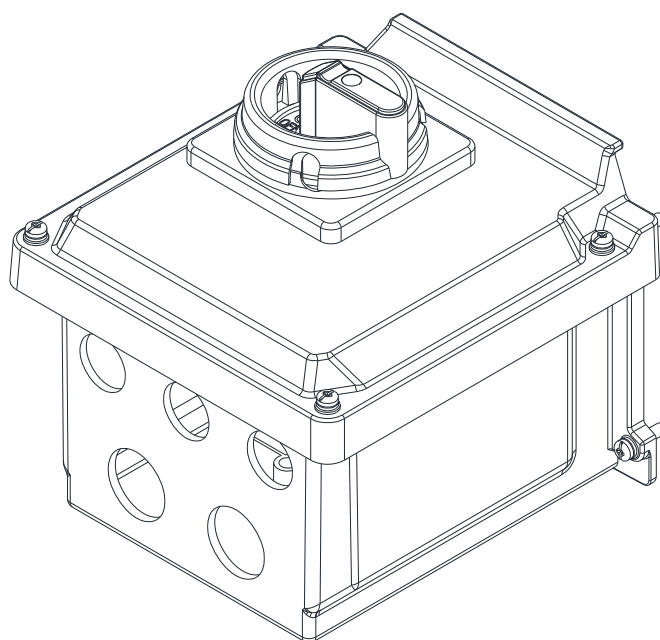
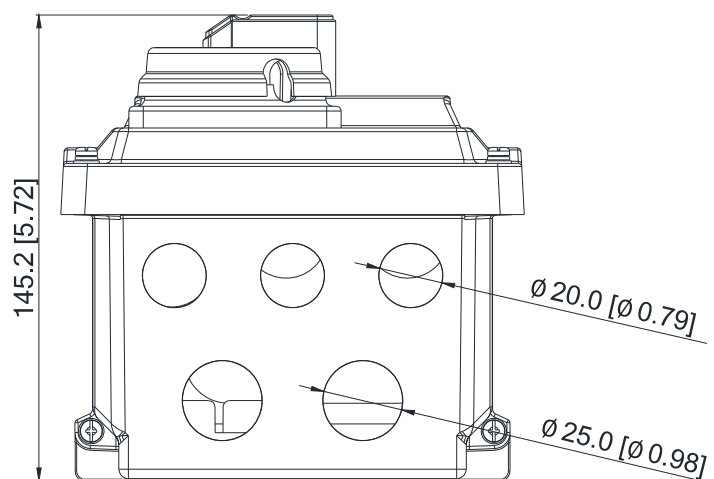
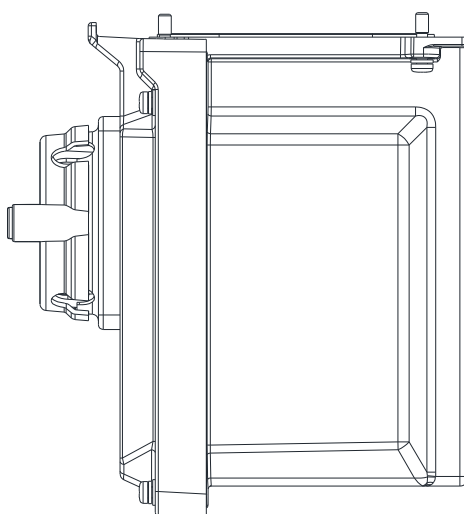
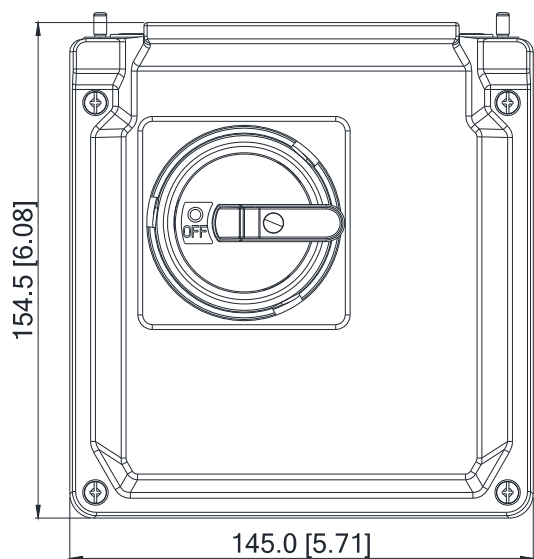

Unit: mm [inch]

The drive with MKMX-SWA

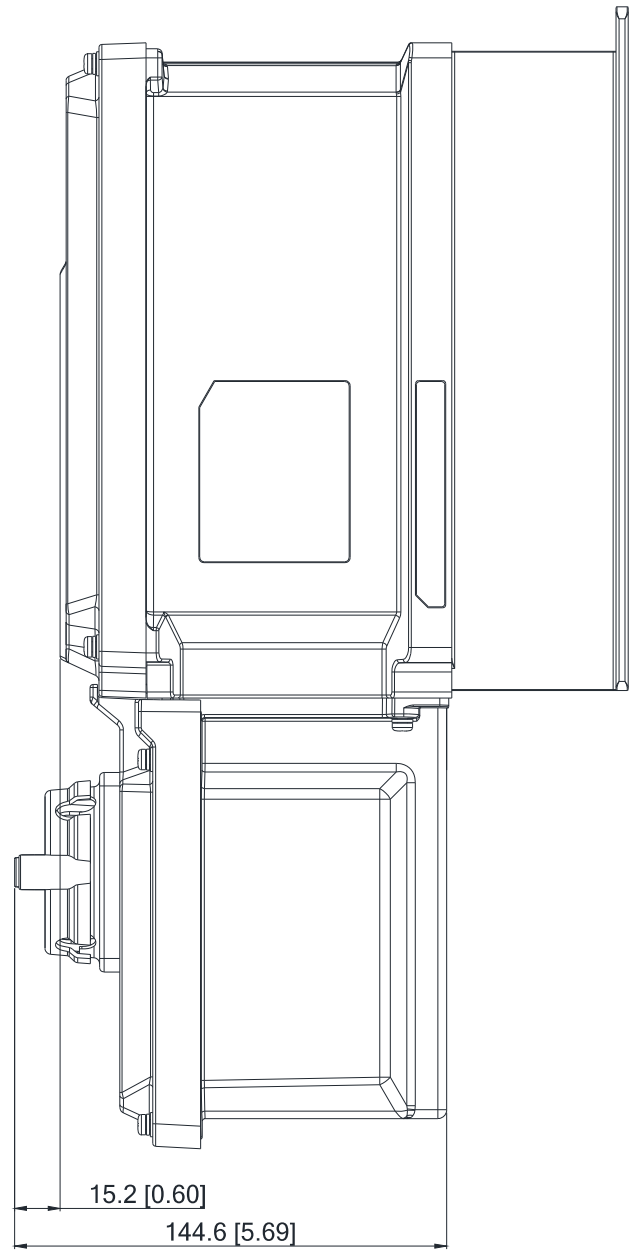
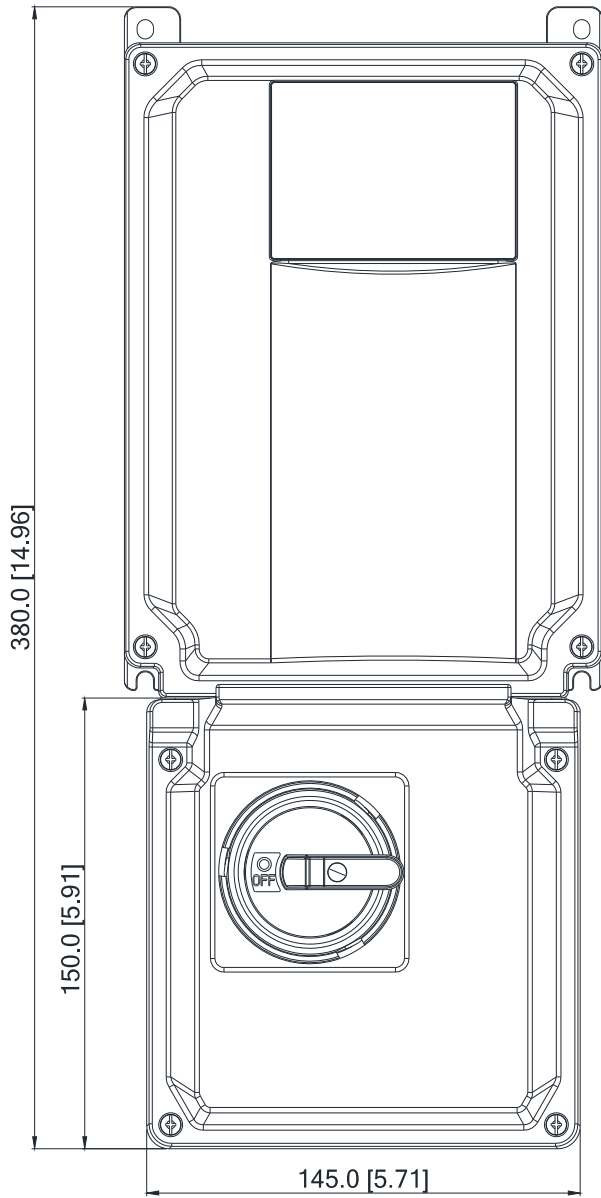

MKMX-SWB (Applicable model: Frame B)

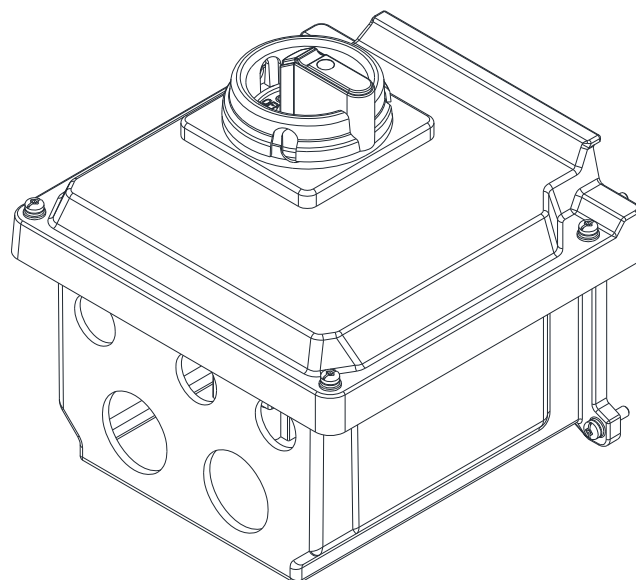
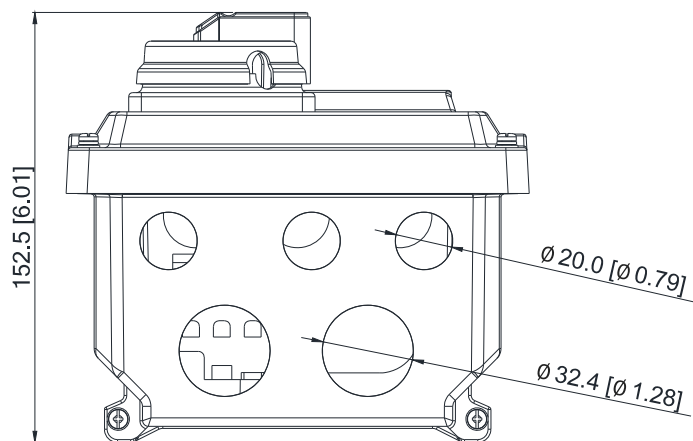
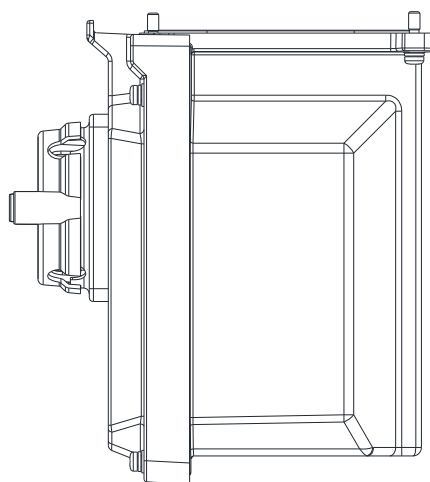
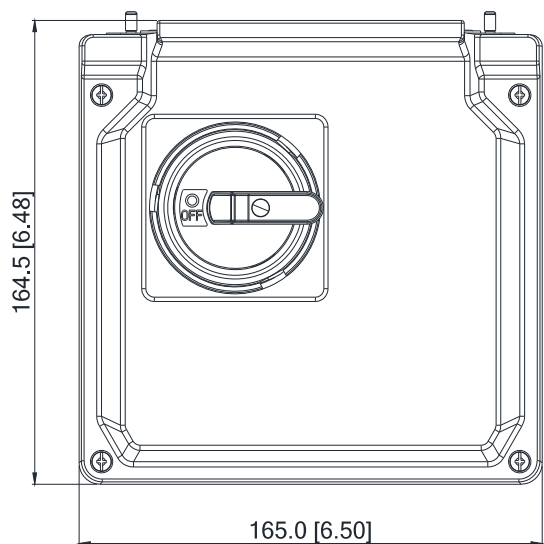

Unit: mm [inch]

The drive with MKMX-SWB

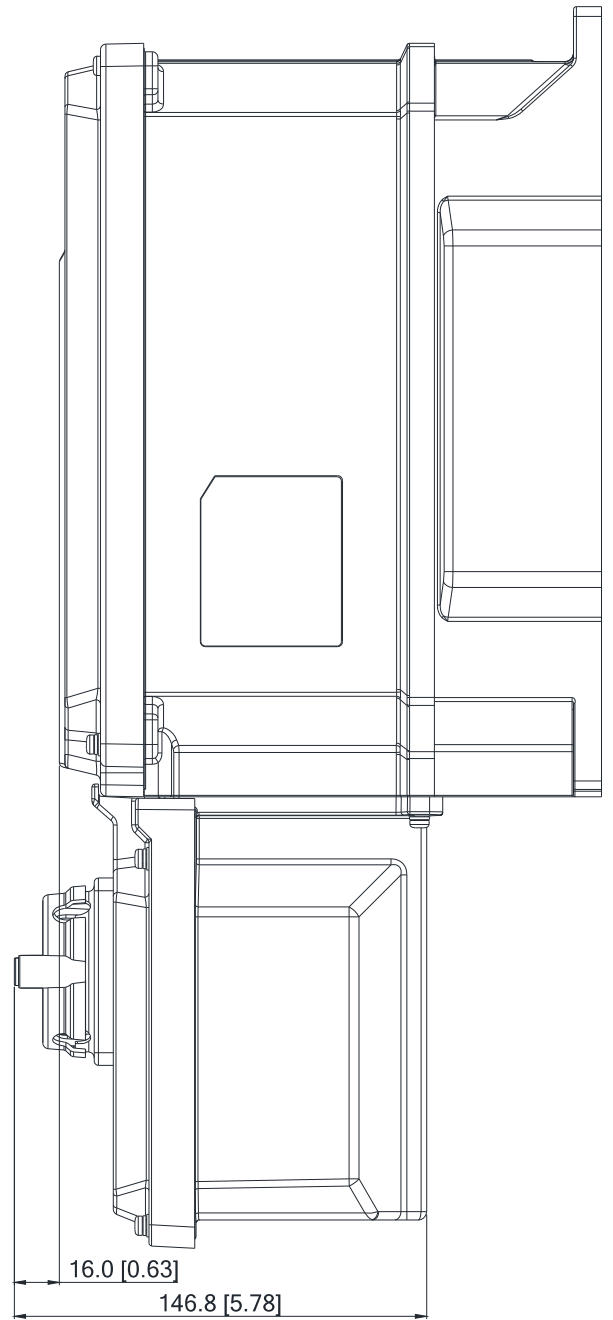
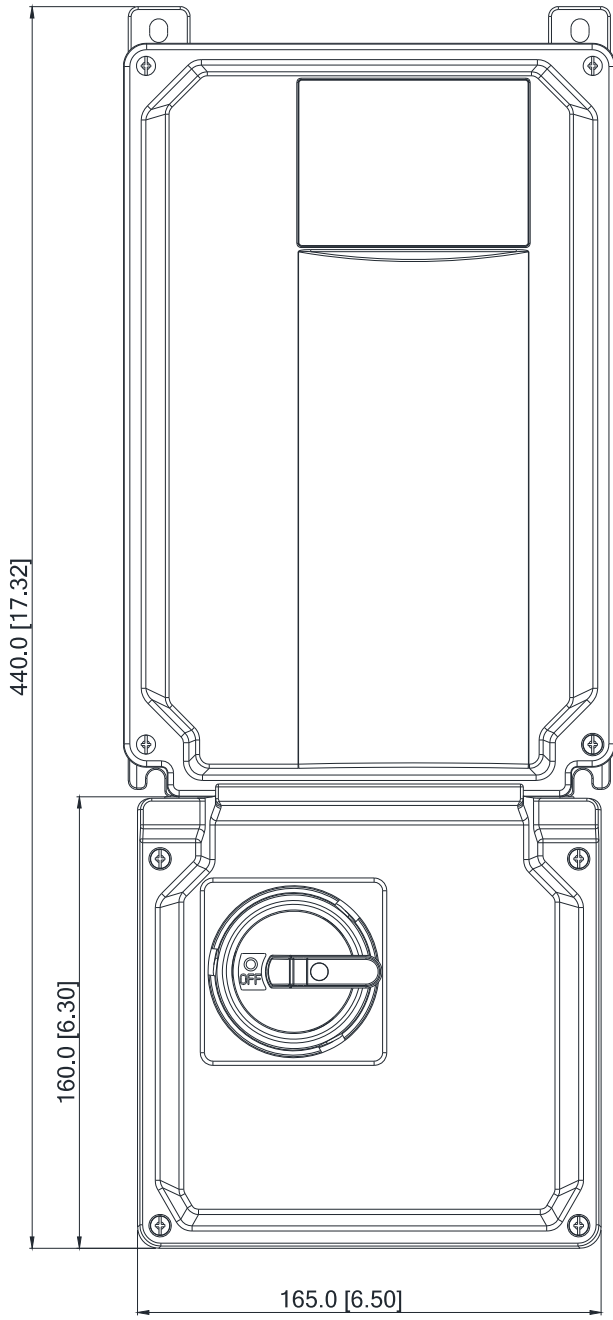

MKMX-SWC (Applicable model: Frame C)

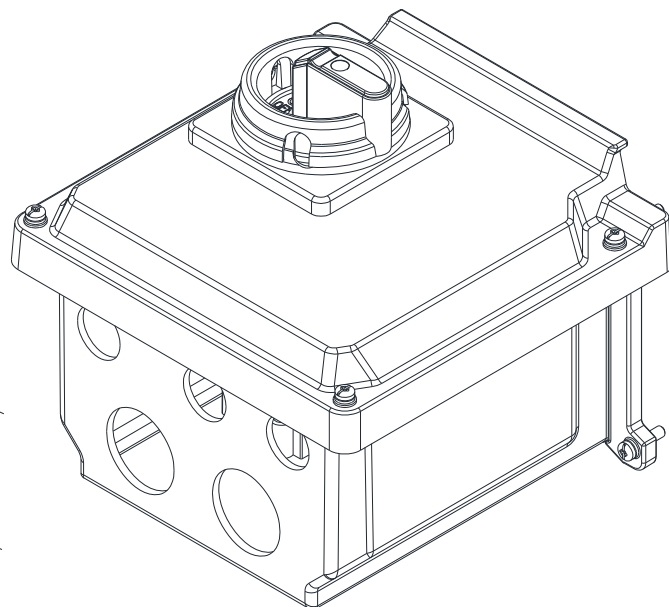
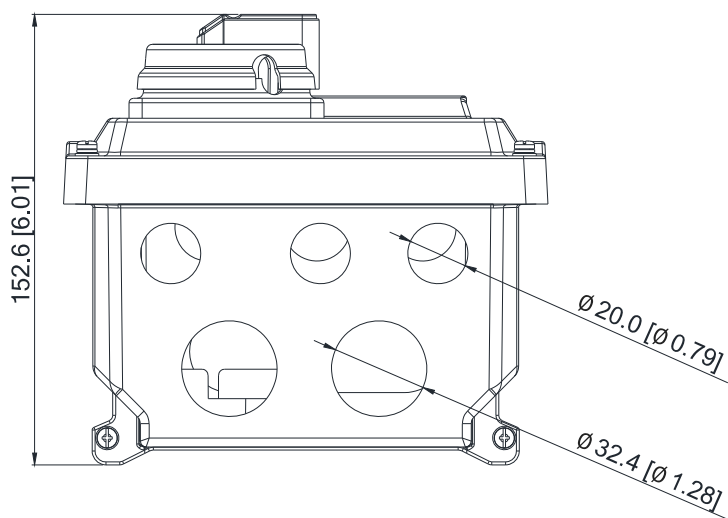
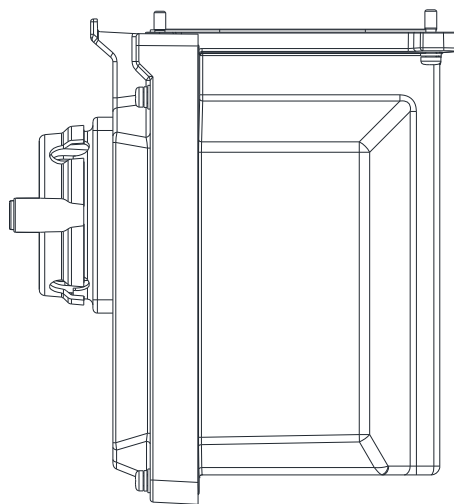
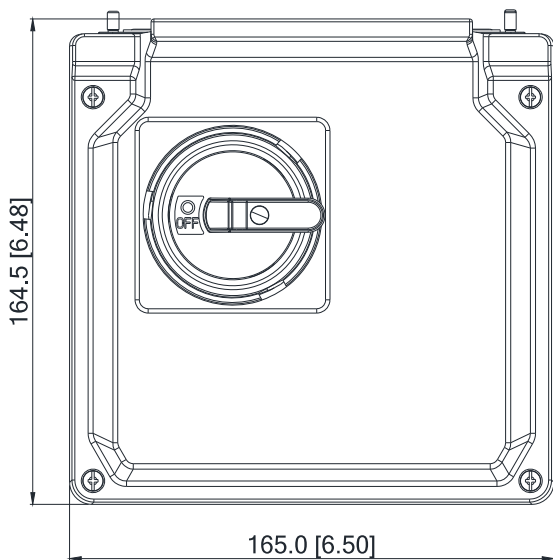

Unit: mm [inch]

The drive with MKMX-SWC

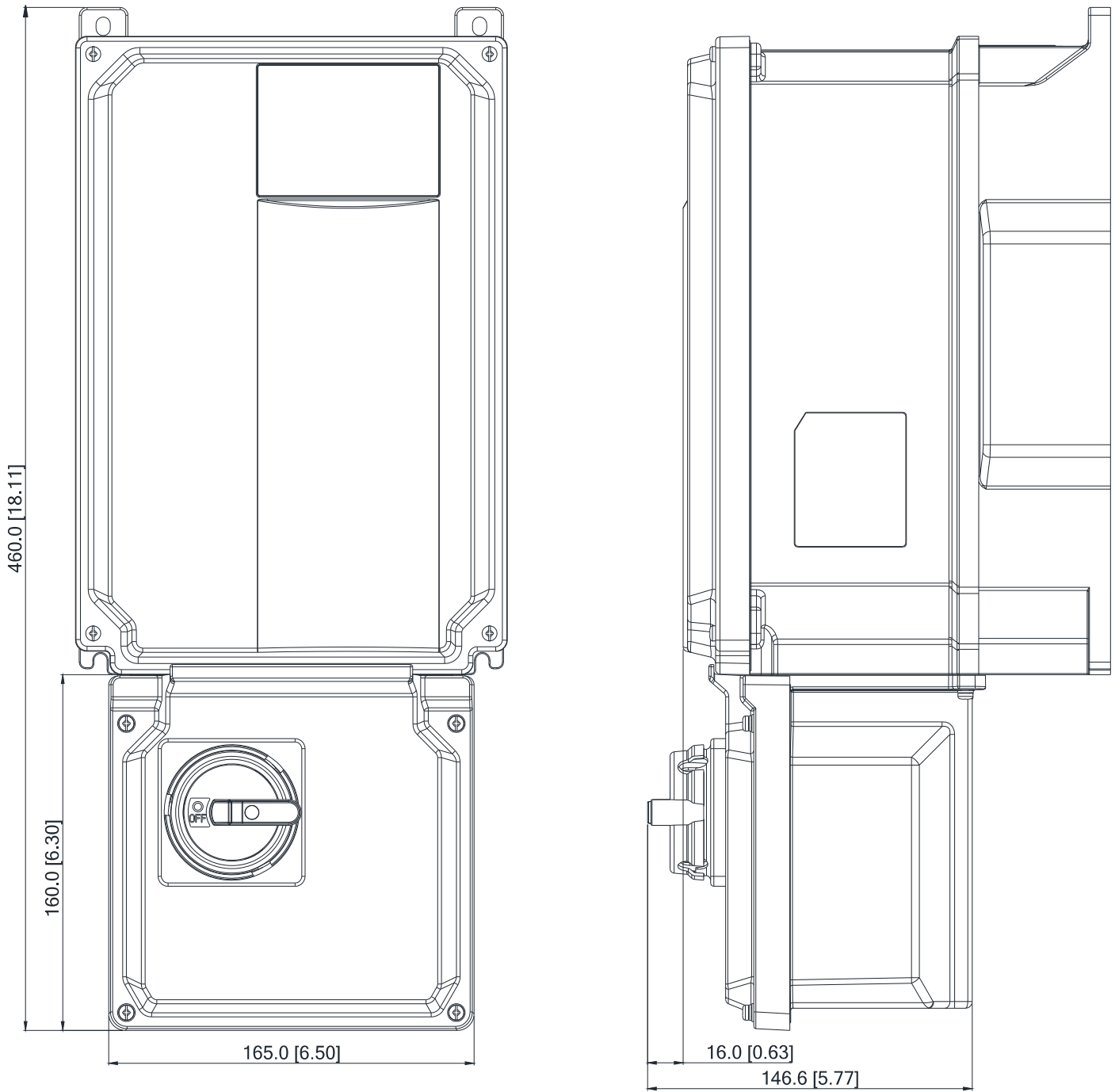

7-10-2 Installation

Before installing the main switch, ensure that the waterproof ring is mounted tightly.

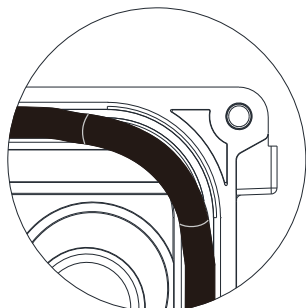

The waterproof ring is falling off.

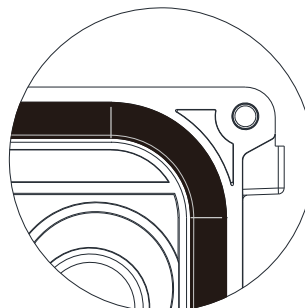

The waterproof ring is mounted tightly.

1. Open the front cover of the drive and remove all waterproof plugs. Then open the front cover of the main switch (keep the switch at OFF position).

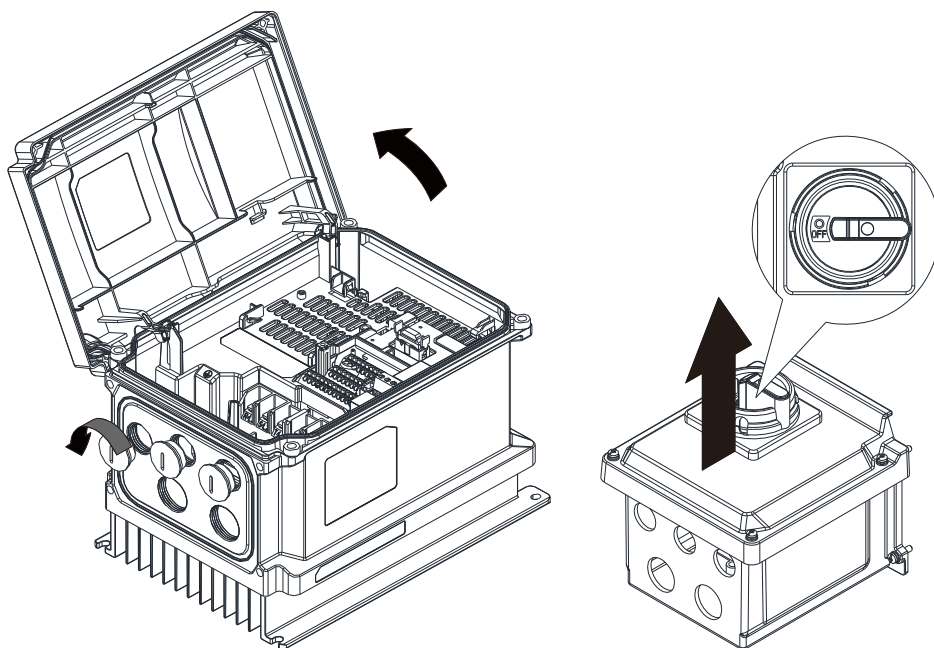

2. Mount the main switch to the drive

Screw: M4 * 4

Torque value: 6–8 kg-cm /
[5.2–6.9 lb-in.] /
[0.59–0.78 Nm]

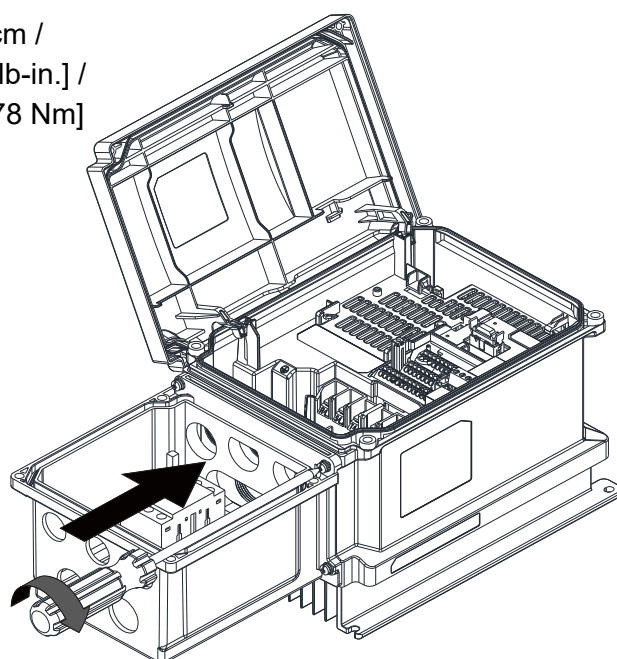

3. Tighten the waterproof connector and waterproof plugs before doing any wiring.

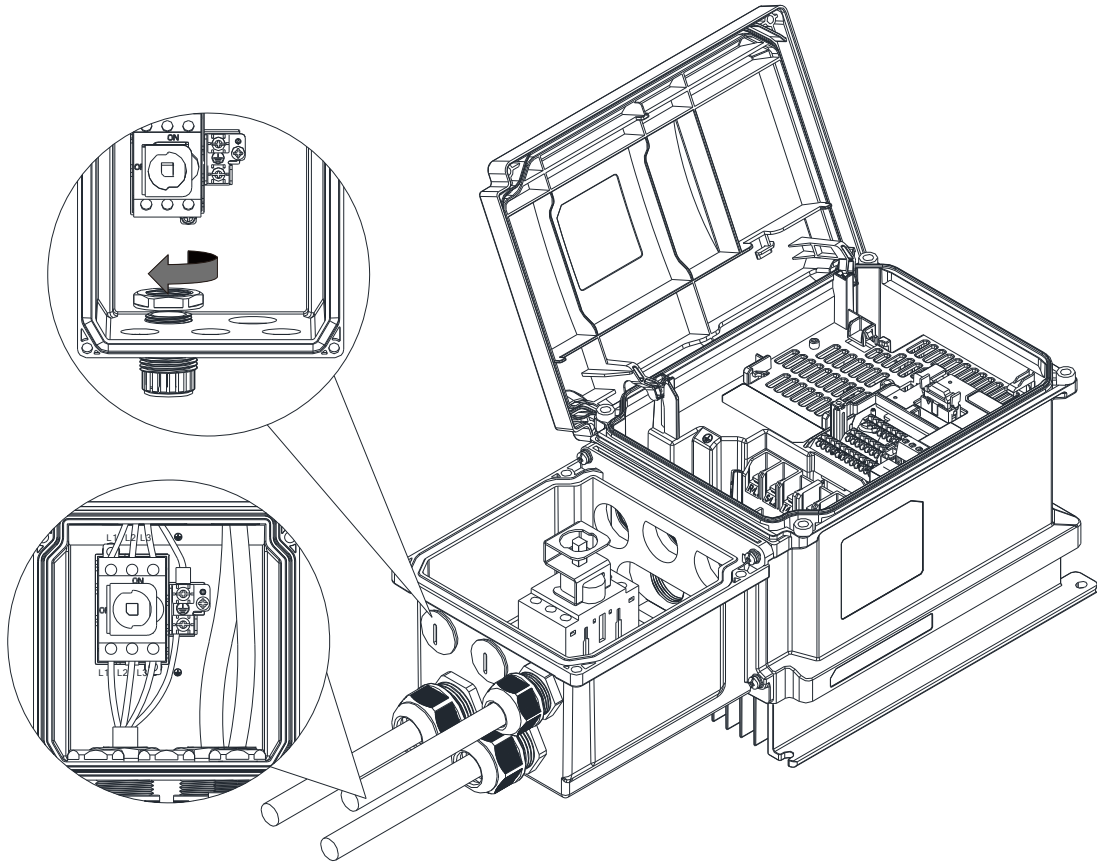

4. Close the front cover of the drive and tighten it.

Screw: M4 * 4

Torque value: 6–8 kg-cm / [5.2–6.9 lb-in.] / [0.59–0.78 Nm]

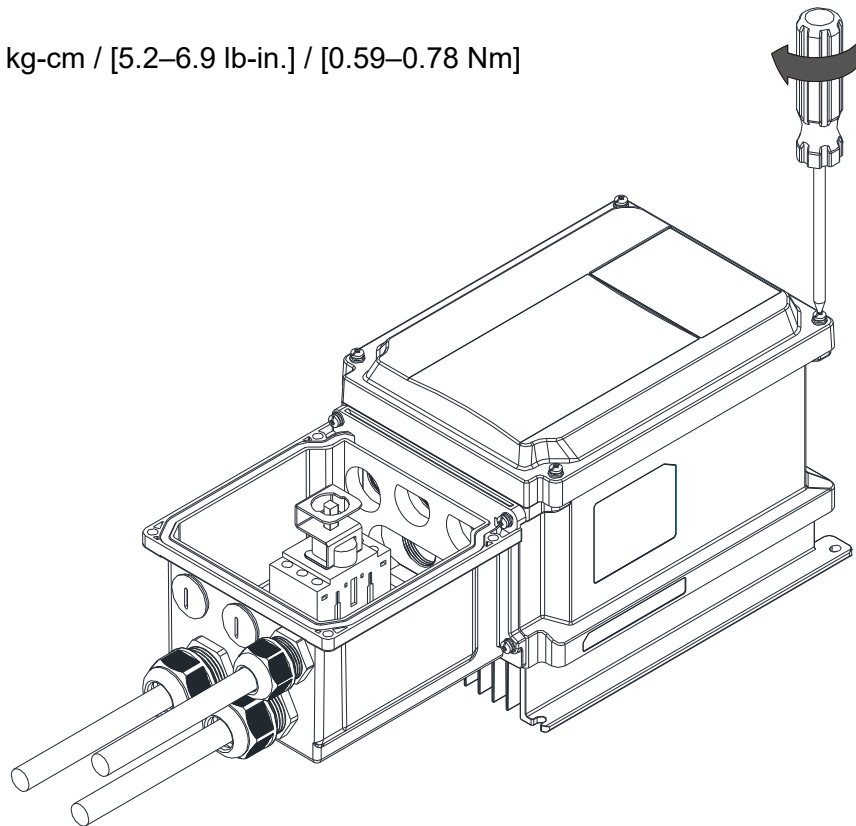

5. Close the front cover of the main switch and tighten it (keep the switch at OFF position)

Screw: M4 * 4

Torque value: 6–8 kg-cm /
[5.2–6.9 lb-in.] /
[0.59–0.78 Nm]

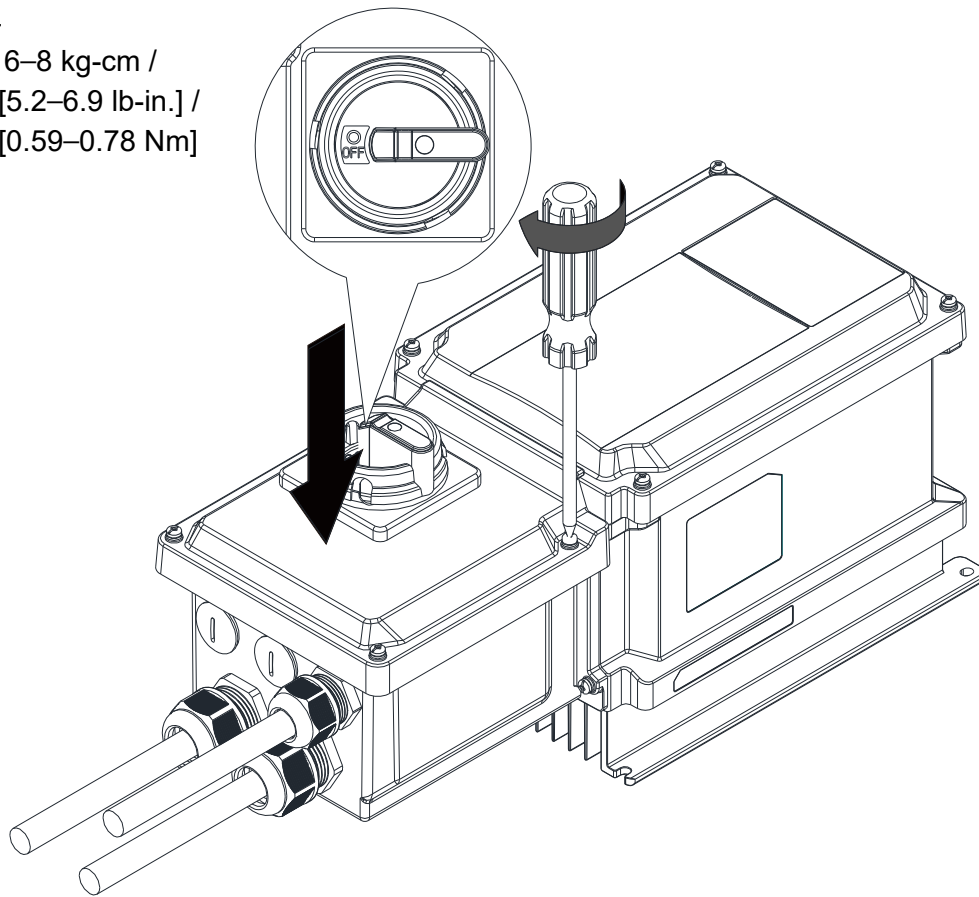

Chapter 8 Option Cards

- 8-1 Option Card Installation
- 8-2 CMM-MOD01 -- Communication Extension Card, Modbus TCP
- 8-3 CMM-PD01 -- Communication Extension Card, PROFIBUS DP
- 8-4 CMM-DN01 -- Communication Extension Card, DeviceNet
- 8-5 CMM-EIP01 -- Communication Extension Card, EtherNet/IP
- 8-6 CMM-COP01 -- Communication Extension Card, CANopen
- 8-7 EMM-BPS01 -- +24 V Power Extension Card
- 8-8 Delta Bus Standard Wire

The option cards in this chapter are optional items. Select the applicable option cards for your motor drive, or contact your local distributor for suggestions. The option cards can significantly improve the efficiency of the motor drive.

To prevent damage to the motor drive during installation, remove the digital keypad and the cover before wiring.

8-1 Option Card Installation

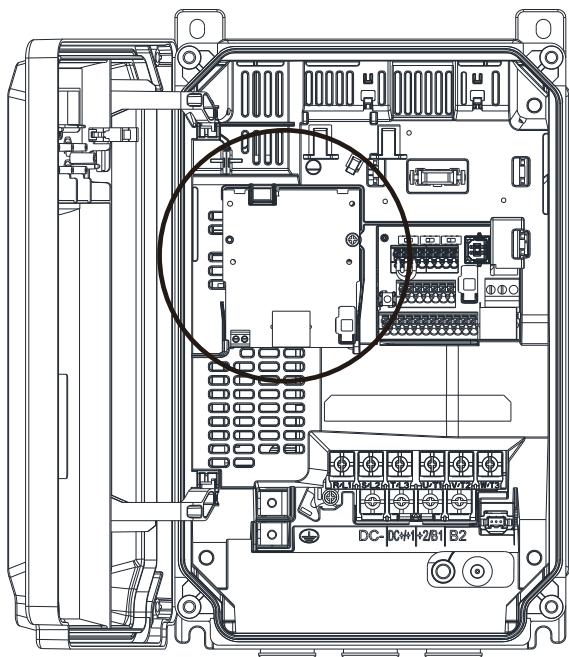

Figure 8-1

1. Switch off the power supply.
2. Open the front cover of the drive.
3. As shown in Figure 8-2, engage the lower end of the option card with the guiding slot.

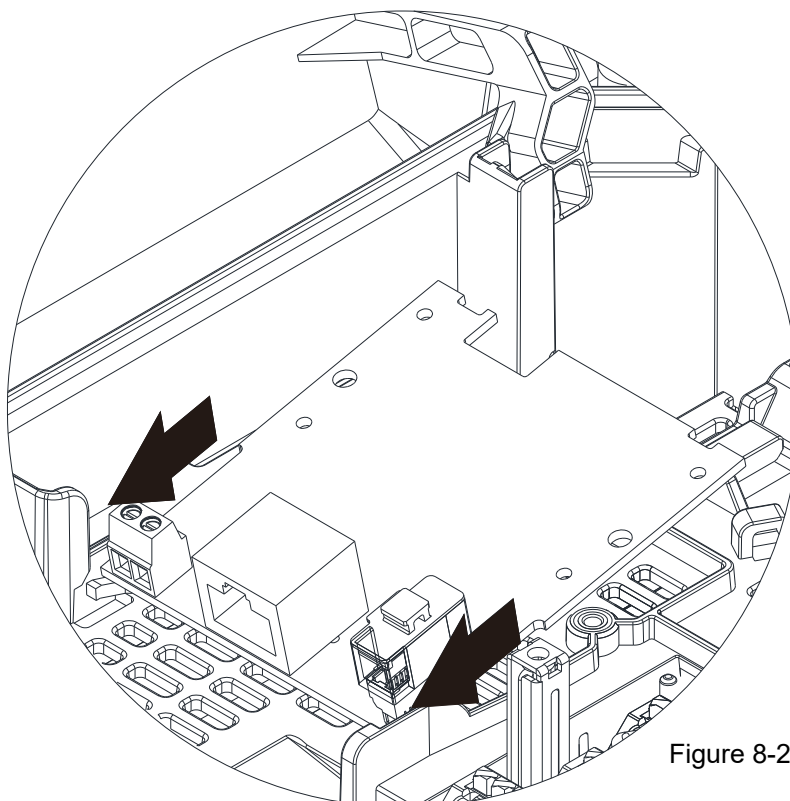

Figure 8-2

4. As shown in Figure 8-3, press the upper end of the option card to engage the clips.

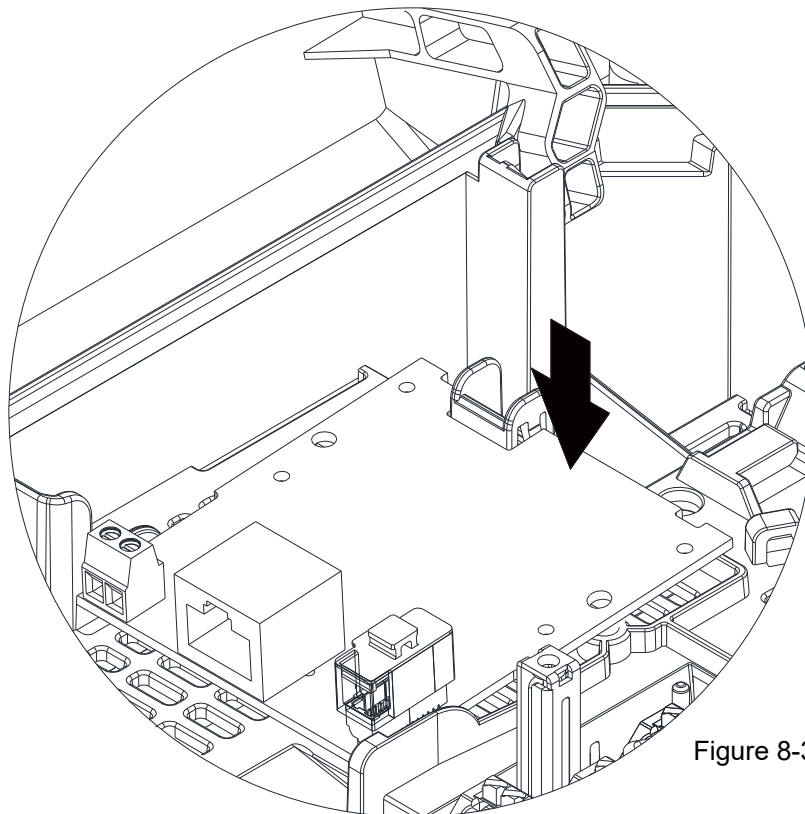
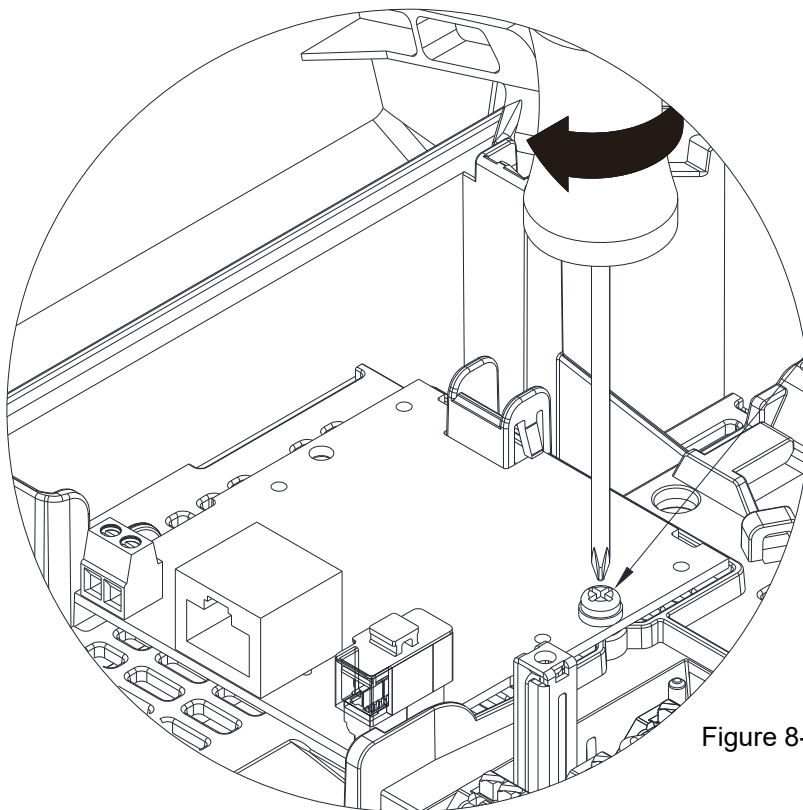

Figure 8-3

5. As shown in Figure 8-4, tighten the option card with a Phillips screwdriver.



Screw: M3
4–6 kg-cm
[3.5–5.2 lb-in]
[0.39–0.59 Nm]

Figure 8-4

NOTE

● Wiring for the Communication Card and Backup Power Supply (BPS) Card Connecting Cables

1. See Figure 8-5 for wiring positions.
2. There are two wire lengths each for the communication card and BPS card connecting cables, and they are both marked with numbers near their connectors at two ends of the cables. The difference is that the BPS card connecting cable is also marked with “BPS01” in the same position. Refer to Figure 8-6 and 8-7 to distinguish them and the table below for the wiring for each frame.
3. Do not confuse these two connecting cables. You must pay attention to the marked words and numbers between them.

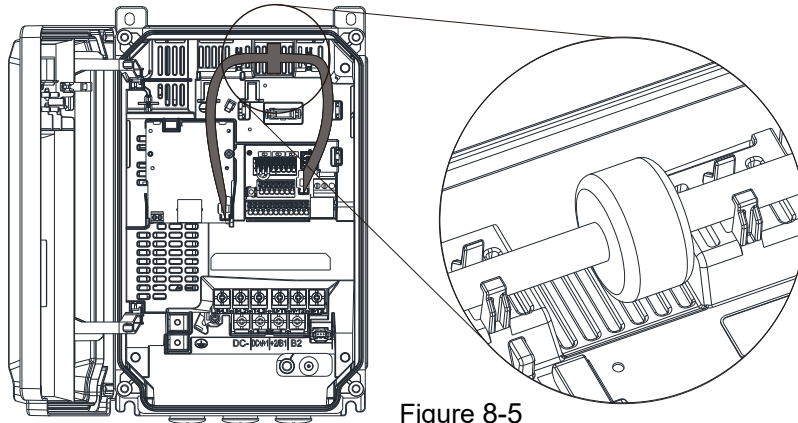

Figure 8-5

Frame	Connect to the Control Board Connector	Connect to the Option Card Connector
A	3	4
B	6	5
C	6	5

CMM-EIP01
 CMM-MOD01
 CMM-COP01
 CMM-PD01
 CMM-DN01

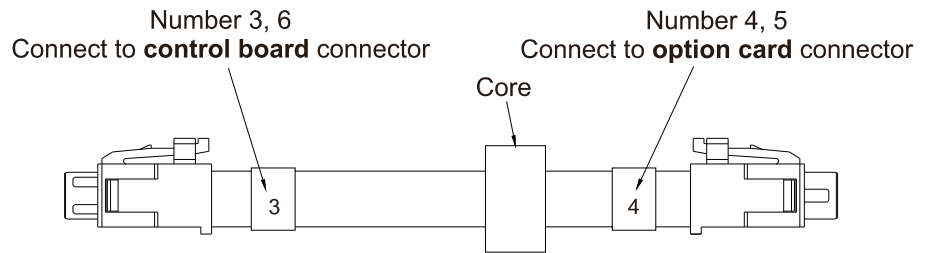

Figure 8-6

EMM-BPS01

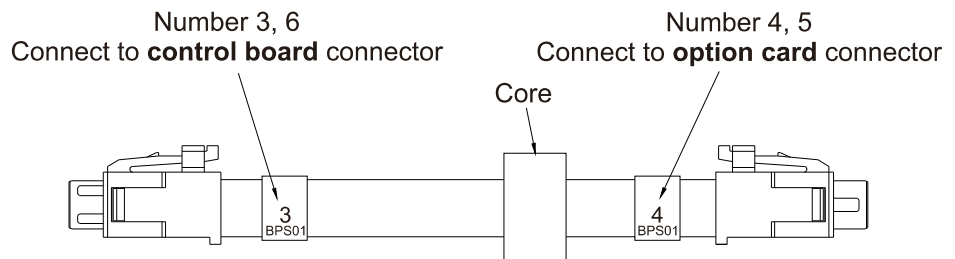

Figure 8-7

- You must ground the option cards listed below before wiring. The ground terminal is included with option cards as shown in Figure 8-8.

- CMM-MOD01
- CMM-PD01
- CMM-DN01
- CMM-EIP01

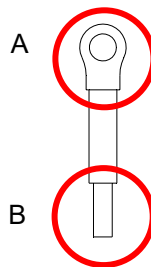

Figure 8-8
Ground terminal

- Installation of the ground terminal:

The B side of the ground terminal connects to the ground terminal block on the option card at No.6 of the CMM-MOD01 shown in Figure 8-9. See each section in Chapter 8 for the ground terminal blocks of the other option cards. The A side of the ground terminal connects to the PE on the drive as the red circles show in Figure 8-10–8-12.

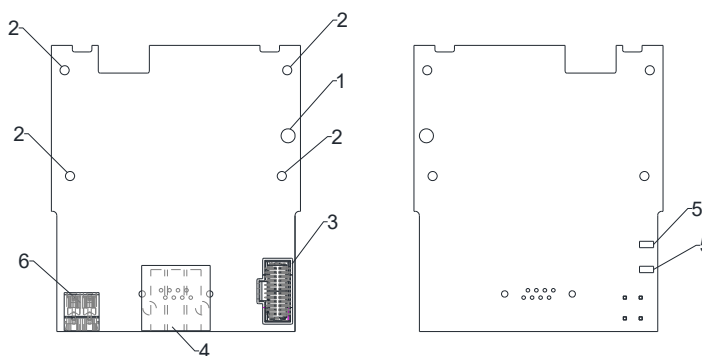

Figure 8-9

Frame A

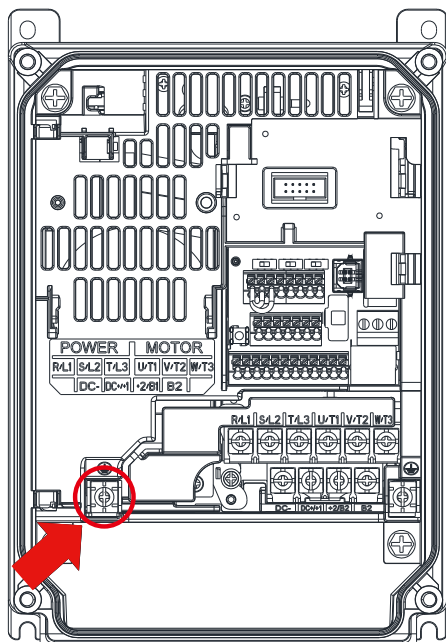

Figure 8-5

Frame B

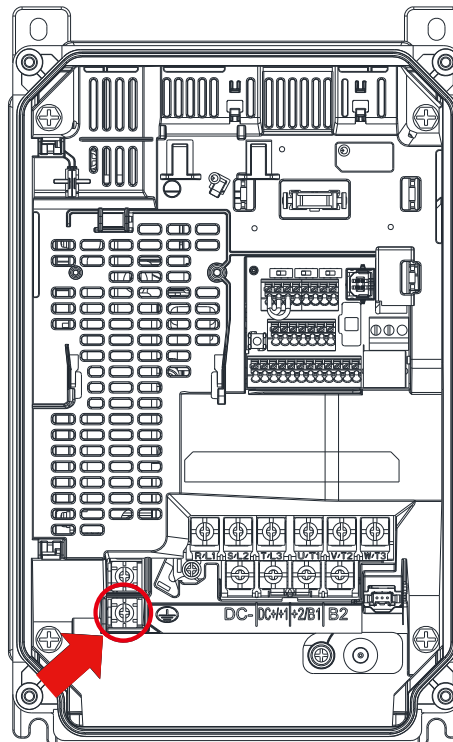

Figure 8-6

Torque ($\pm 10\%$)
20 kg-cm [17.4 lb-in.] [1.96 Nm]

Torque ($\pm 10\%$)
20 kg-cm [17.4 lb-in.] [1.96 Nm]

Frame C

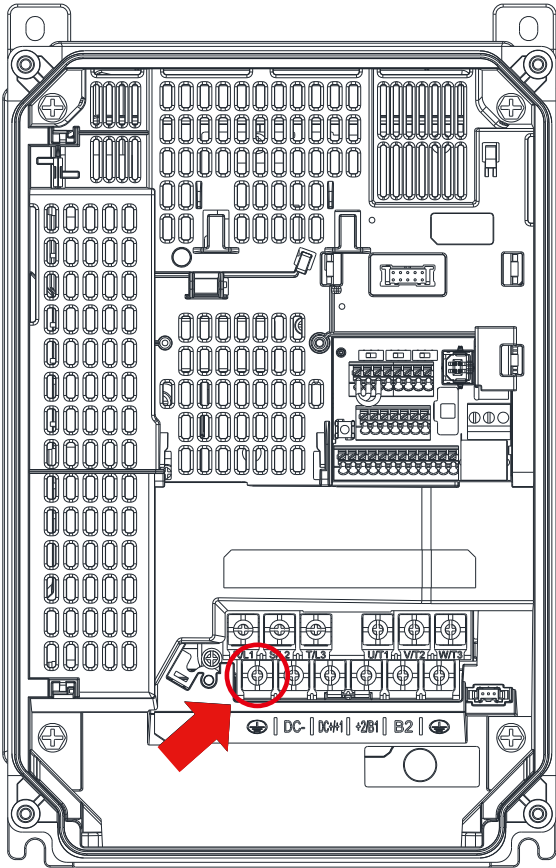

Figure 8-7

Torque ($\pm 10\%$)

20 kg-cm [17.4 lb-in.] [1.96 Nm]

8-2 CMM-MOD01 -- Communication Extension Card, Modbus TCP

Product Profile

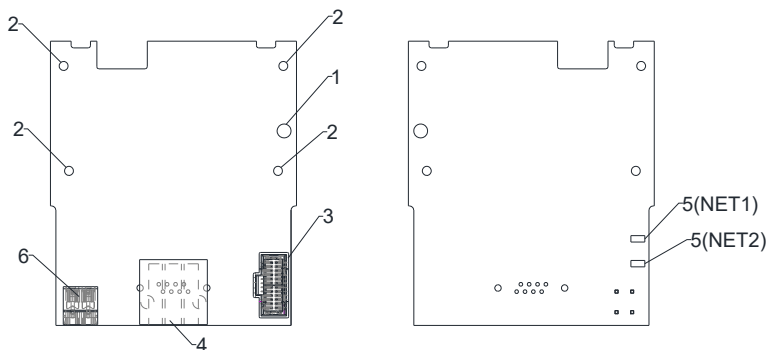

Wire: 0.25–0.5 mm² [24–20 AWG]
 Stripping length: 7–8 mm
 Torque: 2 kg-cm / [1.7 lb-in.] / [0.2 Nm]

1. Screw fixing hole
2. Positioning hole
3. AC motor drive connection port
4. Communication port
5. Indicator
6. Ground terminal block

Features

1. Supports Modbus TCP protocol
2. MDI / MDI-X auto-detect
3. E-mail alarm
4. IP Filter firewall

Specifications

Network Interface

Interface	RJ45 with Auto MDI / MDIX
Number of ports	1 Port
Transmission method	IEEE 802.3, IEEE 802.3u
Transmission cable	Category 5e shielding 100 M
Transmission speed	10/100 Mbps Auto-Detect
Network protocol	ICMP, IP, TCP, UDP, DHCP, SMTP, Modbus TCP, Delta Configuration

Electrical Specification

Power supply voltage	5 V _{DC} (supplied by AC motor drive)
Insulation voltage	500 V _{DC}
Power consumption	0.8 W
Weight	25 g

Environment

Noise immunity	ESD (IEC 61800-5-1, IEC 6100-4-2) EFT (IEC 61800-5-1, IEC 6100-4-4) Surge Test (IEC 61800-5-1, IEC 6100-4-5) Conducted Susceptibility Test (IEC 61800-5-1, IEC 6100-4-6)
----------------	---

Operation / Storage	Operation: -10–50 °C (temperature), 90 % (humidity) Storage: -25–70 °C (temperature), 95 % (humidity)
Shock / Vibration resistance	International standards: IEC 61800-5-1, IEC 60068-2-6 / IEC 61800-5-1, IEC 60068-2-27

■ **MS300 (IP66 / NEMA 4X) Communication Parameters when Connected to EtherNet**

When you connect the MS300 (IP66 / NEMA 4X) to EtherNet, set up the communication parameters based on the table below. The EtherNet master can read and write frequency command words and operation command words for the MS300 (IP66 / NEMA 4X) after you set the communication parameters.

Parameter	Function	Current Set Value	Definition of Parameter Values
00-20	Frequency command source	8	The frequency command is controlled by communication card.
00-21	Operation command source	5	The operation command is controlled by communication card.
09-30	Decoding method for communication	0	Decoding method for the Delta AC motor drive.
09-75	IP setting	0	Static IP(0) / Dynamic distribution IP(1)
09-76	IP address 1	192	IP address <u>192</u> .168.1.5
09-77	IP address 2	168	IP address 192. <u>168</u> .1.5
09-78	IP address 3	1	IP address 192.168. <u>1</u> .5
09-79	IP address 4	5	IP address 192.168.1. <u>5</u>
09-80	Netmask 1	255	Netmask <u>255</u> .255.255.0
09-81	Netmask 2	255	Netmask 255. <u>255</u> .255.0
09-82	Netmask 3	255	Netmask 255.255. <u>255</u> .0
09-83	Netmask 4	0	Netmask 255.255.255. <u>0</u>
09-84	Default gateway 1	192	Default gateway <u>192</u> .168.1.1
09-85	Default gateway 2	168	Default gateway 192. <u>168</u> .1.1
09-86	Default gateway 3	1	Default gateway 192.168. <u>1</u> .1
09-87	Default gateway 4	1	Default gateway 192.168.1. <u>1</u>

■ **Basic Registers**

BR#	R/W	Content	Set Value
#0	R	Model name	Defined by the system. The model code of CMM-MOD01=H'0103.
#1	R	Firmware version	Displays the current firmware version in hex, e.g. H'0100 indicates firmware version V1.00.
#2	R	Release date of the version	Displays the date in decimal form. 10,000s digit and 1,000s digit are for "month"; 100s digit and 10s digit are for "day". For 1 digit: 0 = AM; 1 = PM.
#11	R/W	Modbus Time-out	Pre-defined setting: 500 (ms)
#13	R/W	Keep Alive Time	Pre-defined setting: 30 (s)

■ **LED Indicator & Troubleshooting**

LED Indicators

LED	Status		Indication	Corrective Action
POWER	Green	On	Power supply in normal status	No action is required
	Green	Off	No power supply	Check the power supply

LED	Status		Indication	Corrective Action
LINK	Green	On	Network connection in normal status	No action is required
		Flashes	Network in operation	No action is required
		Off	Network not connected	Check if the network cable is connected

Troubleshooting

Abnormality	Cause	Corrective Action
POWER LED off	AC motor drive not powered	Check if AC motor drive is powered, and if the power supply is normal.
	The CMM-MOD01 not connected to AC motor drive	Make sure CMM-MOD01 is connected to AC motor drive.
LINK LED off	Not connected to network	Make sure the network cable is correctly connected to network.
	Poor contact to RJ45 connector	Make sure the RJ45 connector is connected to EtherNet port.
No module found	The CMM-MOD01 not connected to network	Make sure the CMM-MOD01 is connected to the network.
	The PC and the CMM-MOD01 are in different networks and blocked by network firewall.	Search by IP or set up the relevant settings using the AC motor drive keypad.
Fails to open CMM-MOD01 setup page	The CMM-MOD01 is not connected to network	Make sure the CMM-MOD01 is connected to the network.
	Incorrect communication setting in DCISoft	Make sure the communication setting in DCISoft is set to EtherNet.
	The PC and the CMM-MOD01 are in different networks and blocked by network firewall.	Set up with the AC motor drive keypad.
Able to open CMM-MOD01 setup page but fails to utilize webpage monitoring	Incorrect network setting in the CMM-MOD01	Check if the network setting for the CMM-MOD01 is correct. For the Intranet setting in your company, please consult your IT staff. For the Internet setting at home, please refer to the network setting instruction provided by your ISP.
Fails to send e-mail	Incorrect network setting in the CMM-MOD01	Check if the network setting for the CMM-MOD01 is correct.
	Incorrect mail server setting	Confirm the IP address for the SMTP-Server.

8-3 CMM-PD01 -- Communication Extension Card, PROFIBUS DP

Product Profile

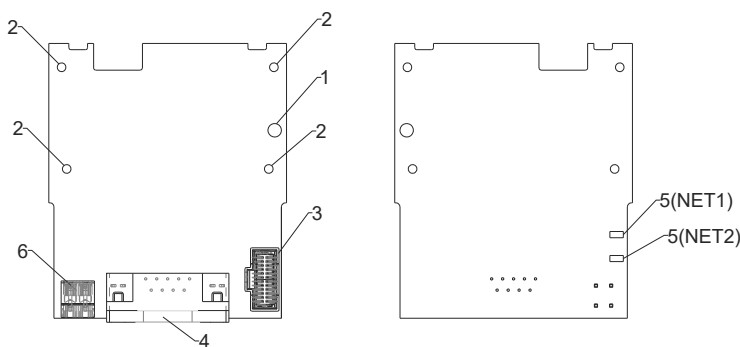

Wire: 0.25–0.5 mm² [24–20 AWG]
 Stripping length: 7–8 mm
 Torque: 2 kg-cm / [1.7 lb-in.] / [0.2 Nm]

- 1. Screw fixing hole
- 2. Positioning hole
- 3. AC motor drive connection port
- 4. Communication port
- 5. Indicator
- 6. Ground terminal block

Features

- 1. Supports PZD control data exchange.
- 2. Supports PKW polling AC motor drive parameters.
- 3. Supports user diagnosis function.
- 4. Auto-detects baud rates; supports maximum of 12 Mbps.

Specifications

PROFIBUS DP Connector

Interface	DB9 connector
Transmission method	High-speed RS-485
Transmission cable	Shielded twisted pair cable
Electrical isolation	500 V _{DC}

Communication

Message type	Cyclic data exchange
Module name	CMM-PD01
GSD document	DELA08DB.GSD
Product ID	08DB (hex)
Serial transmission speed supported (auto-detection)	9.6 kbps; 19.2 kbps; 93.75 kbps; 187.5 kbps; 500 kbps; 1.5 Mbps; 3 Mbps; 6 Mbps; 12 Mbps (bits per second)

Electrical Specification

Power supply	5 V _{DC} (supplied by AC motor drive)
Insulation voltage	500 V _{DC}
Power consumption	1 W
Weight	28 g

Environment

Noise immunity	ESD (IEC 61800-5-1, IEC 6100-4-2) EFT (IEC 61800-5-1, IEC 6100-4-4) Surge Test (IEC 61800-5-1, IEC 6100-4-5) Conducted Susceptibility Test (IEC 61800-5-1, IEC 6100-4-6)
Operation / Storage	Operation: -10–50 °C (temperature), 90 % (humidity) Storage: -25–70 °C (temperature), 95 % (humidity)
Shock / Vibration resistance	International standards: IEC61131-2, IEC68-2-6 (TEST Fc) / IEC61131-2 & IEC 68-2-27 (TEST Ea)

■ **Installation**

PROFIBUS DP connector pin assignment

PIN	PIN name	Definition
1	-	Not defined
2	-	Not defined
3	Rxd / Txd-P	Sending / receiving data P(B)
4	-	Not defined
5	DGND	Data reference ground
6	VP	Power voltage – positive
7	-	Not defined
8	Rxd / Txd-N	Sending / receiving data N(A)
9	-	Not defined

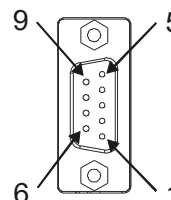

■ **LED Indicator & Troubleshooting**

There are two LED indicators on the CMM-PD01: POWER LED and NET LED. POWER LED displays the status of the working power. NET LED displays the connection status of the communication.

POWER LED

LED status	Indication	Corrective Action
Green light on	Power supply in normal status.	No action is required.
Off	No power	Check if the connection between the CMM-PD01 and the AC motor drive is normal.

NET LED

LED status	Indication	Corrective Action
Green light on	Normal status	No action is required.
Red light on	The CMM-PD01 is not connected to PROFIBUS DP bus.	Connect the CMM-PD01 to the PROFIBUS DP bus.
Red light flashes	Invalid PROFIBUS communication address	Set the PROFIBUS address of the CMM-PD01 between 1–125 (decimal).
Orange light flashes	The CMM-PD01 fails to communicate with AC motor drive.	Switch off the power and check whether the CMM-PD01 is installed correctly and connected normally to the AC motor drive.

8-4 CMM-DN01 -- Communication Extension Card, DeviceNet

Product Profile

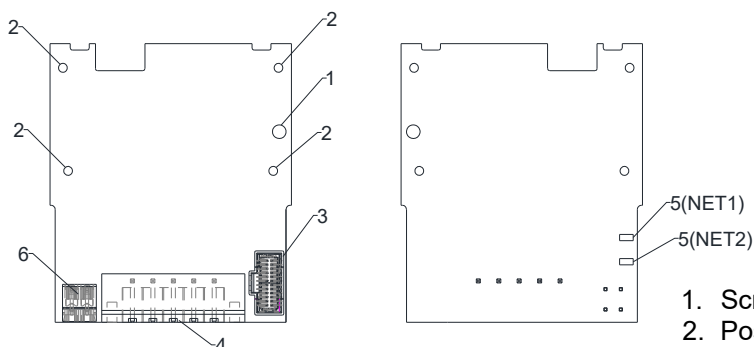

Wire: 0.25–0.5 mm² [24–20 AWG]
 Stripping length: 7–8 mm
 Torque: 2 kg-cm / [1.7 lb-in.] / [0.2 Nm]

1. Screw fixing hole
2. Positioning hole
3. AC motor drive connection port
4. Communication Port
5. Indicator
6. Ground terminal block

Features

1. Based on the high-speed communication interface of Delta's HSSP protocol, the AC motor drive can be controlled in real-time.
2. Supports Group 2 only connection and polling I/O data exchange.
3. For I/O mapping, supports a maximum of 32 words input and 32 words output.
4. Supports EDS file configuration in DeviceNet configuration software.
5. Supports all baud rates on DeviceNet bus: 125 kbps, 250 kbps, 500 kbps and extendable baud rate mode.
6. Node address and baud rate can be set in the AC motor drive.
7. Power is supplied from the AC motor drive.

Specifications

DeviceNet Connector

Interface	5-PIN open pluggable connector. PIN interval: 5.08 mm
Transmission method	CAN
Transmission cable	Shielded twisted pair cable (with 2 power cables)
Transmission speed	125 kbps, 250 kbps, 500 kbps and extendable baud rate mode
Network protocol	DeviceNet protocol

AC Motor Drive Connection Port

Interface	50 PIN communication terminal
Transmission method	SPI communication
Terminal function	<ol style="list-style-type: none"> 1. Communication module communicates with AC motor drive through this port. 2. AC motor drive provides power supply to communication module through this port.
Communication protocol	Delta HSSP protocol

Electrical Specification

Power supply voltage	5 V _{DC} (supplied by AC motor drive)
Insulation voltage	500 V _{DC}
Communication wire power consumption	0.85 W
Power consumption	1 W
Weight	23 g

Environment

Noise immunity	ESD (IEC 61800-5-1, IEC 6100-4-2) EFT (IEC 61800-5-1, IEC 6100-4-4) Surge Test (IEC 61800-5-1, IEC 6100-4-5) Conducted Susceptibility Test (IEC 61800-5-1, IEC 6100-4-6)
Operation / Storage	Operation: -10–50 °C (temperature), 90% (humidity) Storage: -25–70 °C (temperature), 95% (humidity)
Shock / Vibration resistance	International standards: IEC 61800-5-1, IEC 60068-2-6 / IEC 61800-5-1, IEC 60068-2-27

DeviceNet Connector

PIN	Signal	Color	Definition
1	V+	Red	24 V _{DC}
2	H	White	Signal+
3	S	-	Ground
4	L	Blue	Signal-
5	V-	Black	0 V

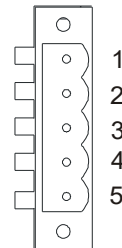

■ LED Indicator & Troubleshooting

There are three LED indicators on CMM-DN01. POWER LED displays the status of power supply. MS LED and NS LED are dual-color LEDs, displaying the connection status and error messages of the communication module.

POWER LED

LED status	Indication	Corrective Action
On	Power supply in abnormal status	Check the power supply of the CMM-DN01.
Off	Power supply in normal status	No action is required.

NS LED

LED status	Indication	Corrective Action
Off	No power supply or the CMM-DN01 has not completed MAC ID test yet.	<ol style="list-style-type: none"> 1. Check the power to the CMM-DN01 and see if the connection is normal. 2. Make sure there is at least one node on the bus. 3. Check if the baud rate of the CMM-DN01 is the same as that of the other nodes.
Green light flashes	The CMM-DN01 is on-line but has not established connection to the master.	<ol style="list-style-type: none"> 1. Configure the CMM-DN01 to the scan list of the master. 2. Re-download the configured data to the master.
Green light on	The CMM-DN01 is on-line and is normally connected to the master.	No action is required.
Red light flashes	The CMM-DN01 is on-line, but I/O connection is timed-out.	<ol style="list-style-type: none"> 1. Check if the network connection is normal. 2. Check if the master operates normally.
Red light on	<ol style="list-style-type: none"> 1. The communication is down. 2. MAC ID test failure. 3. No network power supply. 4. CMM-DN01 is off-line. 	<ol style="list-style-type: none"> 1. Make sure all MAC IDs on the network are unique. 2. Check if the network installation is normal. 3. Check if the baud rate of the CMM-DN01 is consistent with that of the other nodes. 4. Check if the node address of the CMM-DN01 is illegal. 5. Check if the network power supply is normal.

MS LED

LED status	Indication	Corrective Action
Off	No power supply or device is off-line.	Check the power supply of the CMM-DN01 and see if the connection is normal.
Green light flashes	Waiting for I/O data	Switch the master PLC to RUN status.
Green light on	I/O data are normal.	No action is required.
Red light flashes	Mapping error	<ol style="list-style-type: none"> 1. Reconfigure the CMM-DN01. 2. Re-power the AC motor drive.
Red light on	Hardware error	<ol style="list-style-type: none"> 1. See the error code on the drive's keypad. 2. Send back to the factory for repair if necessary.
Orange light flashes	The CMM-DN01 is establishing a connection with the AC motor drive.	If the flashing lasts for a long time, check if the CMM-DN01 and the AC motor drive are correctly installed and correctly connected to each other.

8-5 CMM-EIP01 -- Communication Extension Card, EtherNet/IP

Product Profile

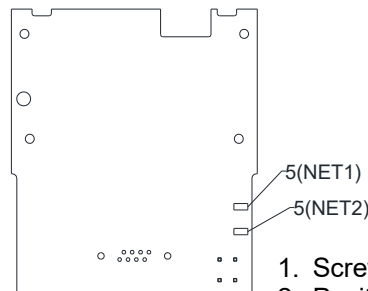
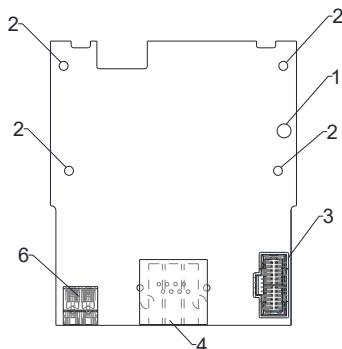

1. Screw fixing hole
2. Positioning hole
3. AC motor drive connection port
4. Communication port
5. Indicator
6. Ground terminal block

Wire: 0.25–0.5 mm² [24–20 AWG]

Stripping length: 7–8 mm

Torque: 2 kg-cm / [1.7 lb-in.] / [0.2 Nm]

Features

1. Supports Modbus TCP and EtherNet/IP protocol
2. 32 / 32 words read/write parameters mapping
3. User-defined corresponding parameters
4. MDI / MDI-X auto-detect
5. E-mail alarm
6. IP Filter firewall

Specifications

Network Interface

Interface	RJ45 with Auto MDI / MDIX
Number of ports	1 Port
Transmission method	IEEE 802.3, IEEE 802.3u
Transmission cable	Category 5e shielding 100 M
Transmission speed	10/100 Mbps Auto-Detect
Network protocol	ICMP, IP, TCP, UDP, DHCP, HTTP, SMTP, Modbus TCP, EtherNet / IP, Delta Configuration

Electrical Specification

Insulation voltage	500 V _{DC}
Power consumption	0.8 W
Power supply voltage	5 V _{DC}
Weight	25 g

Environment

Noise immunity	ESD (IEC 61800-5-1, IEC 61000-4-2) EFT (IEC 61800-5-1, IEC 61000-4-4) Surge Test (IEC 61800-5-1, IEC 61000-4-5) Conducted Susceptibility Test (IEC 61800-5-1, IEC 61000-4-6)
----------------	---

Operation / Storage	Operation: -10–50 °C (temperature), 90 % (humidity) Storage: -25–70 °C (temperature), 95 % (humidity)
Shock / Vibration resistance	International standard: IEC 61800-5-1, IEC 60068-2-6 / IEC 61800-5-1, IEC 60068-2-27

■ **Installation**

Connecting the CMM-EIP01 to the Network

1. Switch off the power supply.
2. Open the front cover of the drive.
3. Connect the CAT-5e network cable to the RJ45 port on the CMM-EIP01 (as shown in the right figure).

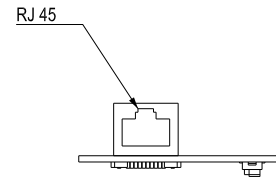

RJ45 PIN Definition

PIN	Signal	Definition	PIN	Signal	Definition
1	Tx+	Data transmit positive	5	--	N/C
2	Tx-	Data transmit negative	6	Rx-	Data receive negative
3	Rx+	Data receive positive	7	--	N/C
4	--	N/C	8	--	N/C

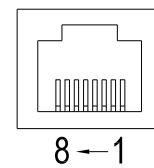

■ **MS300 (IP66 / NEMA 4X) Communication Parameters when Connected to EtherNet**

When you connect the MS300 (IP66 / NEMA 4X) to EtherNet, set up the communication parameters based on the table below. The EtherNet master can read and write the frequency command words and operation command words for the MS300 (IP66 / NEMA 4X) after you set the communication parameters.

Parameter	Function	Current Set Value	Definition of Parameter Values
00-20	Frequency command source	8	The frequency command is controlled by the communication card.
00-21	Operation command source	5	The operation command is controlled by the communication card.
09-30	Decoding method for communication	0	The decoding method for Delta AC motor drive.
09-75	IP setting	0	Static IP(0) / Dynamic distribution IP(1)
09-76	IP address 1	192	IP address <u>192</u> .168.1.5
09-77	IP address 2	168	IP address 192. <u>168</u> .1.5
09-78	IP address 3	1	IP address 192.168. <u>1</u> .5
09-79	IP address 4	5	IP address 192.168.1. <u>5</u>
09-80	Netmask 1	255	Netmask <u>255</u> .255.255.0
09-81	Netmask 2	255	Netmask 255. <u>255</u> .255.0
09-82	Netmask 3	255	Netmask 255.255. <u>255</u> .0
09-83	Netmask 4	0	Netmask 255.255.255. <u>0</u>
09-84	Default gateway 1	192	Default gateway <u>192</u> .168.1.1
09-85	Default gateway 2	168	Default gateway 192. <u>168</u> .1.1
09-86	Default gateway 3	1	Default gateway 192.168. <u>1</u> .1
09-87	Default gateway 4	1	Default gateway 192.168.1. <u>1</u>

■ LED Indicator & Troubleshooting

There are two LED indicators on CMM-EIP01: POWER LED and LINK LED. POWER LED displays the status of the working power, and LINK LED displays the connection status of the communication.

LED Indicators

LED	Status	Indication	Corrective Action	
POWER	Green	On	Power supply in normal status	No action is required.
		Off	No power supply	Check the power supply.
LINK	Green	On	Network connection in normal status	No action is required.
		Flashes	Network in operation	No action is required.
		Off	Network not connected	Check if the network cable is connected.

Troubleshooting

Abnormality	Cause	Corrective Action
POWER LED off	The AC motor drive is not powered.	Check if the AC motor drive is powered, and if the power supply is normal.
	The CMM-EIP01 is not connected to the AC motor drive.	Make sure the CMM-EIP01 is connected to the AC motor drive.
LINK LED off	The CMM-EIP01 is not connected to network.	Make sure the network cable is correctly connected to network.
	Poor contact to the RJ45 connector	Make sure the RJ45 connector is connected to the EtherNet port.
No communication card found	The CMM-EIP01 is not connected to the network.	Make sure the CMM-EIP01 is connected to the network.
	The PC and the CMM-EIP01 are in different networks and blocked by network firewall.	Search by IP or set up relevant settings using the AC motor drive keypad.
Fail to open CMC-EIP01 setup page	The CMM-EIP01 is not connected to the network.	Make sure the CMM-EIP01 is connected to the network.
	Incorrect communication setting in DCISoft	Make sure the communication setting in DCISoft is set to EtherNet.
	The PC and the CMM-EIP01 are in different networks and blocked by network firewall.	Set up with the AC motor drive keypad.
Able to open CMC-EIP01 setup page but fails to utilize webpage monitoring	Incorrect network setting in the CMM-EIP01	Check if the network setting for the CMM-EIP01 is correct. For the Intranet setting in your company, please consult your IT staff. For the Internet setting at home, please refer to the network setting instruction provided by your ISP.
Fails to send e-mail	Incorrect network setting in the CMM-EIP01	Check if the network setting for the CMM-EIP01 is correct.
	Incorrect mail server setting	Confirm the IP address for the SMTP-Server.

8-6 CMM-COP01 -- Communication Extension Card, CANopen

Product Profile

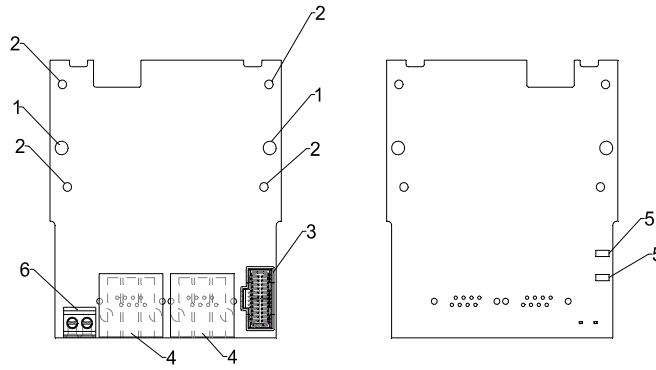
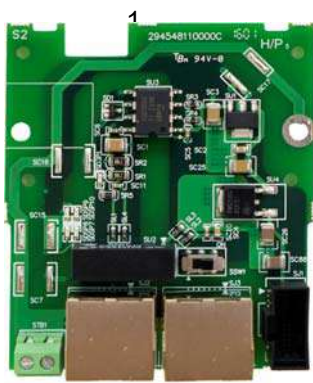

1. Screw fixing hole
2. Positioning hole
3. AC motor drive connection port
4. Communication port
5. Indicator
6. Ground terminal block

Wire: 0.25–0.5 mm² [24–20 AWG]

Stripping length: 7–8 mm

Torque: 2 kg-cm / [1.7 lb-in.] / [0.2 Nm]

RJ45 Pin definition

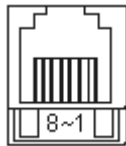

Socket

Pin	Signal	Description
3	SGND	Ground / 0V / V-
4	SG-	–
5	SG+	–
7	SGND	Ground / 0V / V-
8	+10VS	–

Specifications

Interface	RJ45
Number of ports	1 Port
Transmission method	CAN
Transmission cable	CAN standard cable
Transmission speed	1 Mbps; 500 kbps; 250 kbps; 125 kbps; 100 kbps; 50 kbps
Communication protocol	CANopen protocol
Terminating resistance	Controlled by SSW1. If you switch SSW1 to the left, you close the terminating resistance and must be connected externally. If you switch SSW1 to the right, you open the terminating resistance and it can be connected internally.

CANopen Communication Cable

Model: TAP-CN03

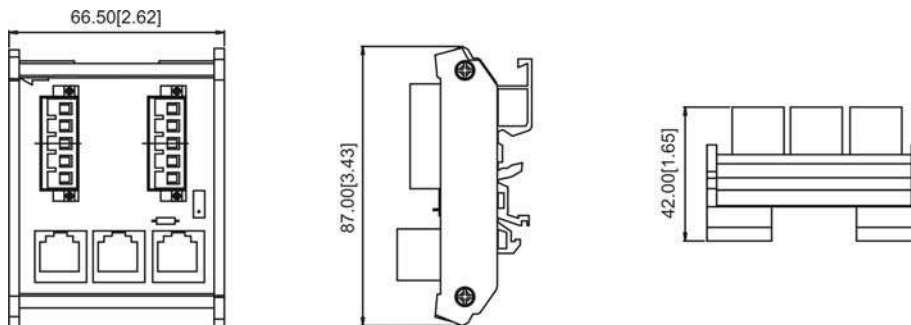

NOTE

For more information on CANopen, please refer to the CANopen user manual or download the related manuals from the Delta website: http://www.deltaww.com/iadownload_acmotordrive

8-7 EMM-BPS01 -- +24 V Power Extension Card

■ Product Profile

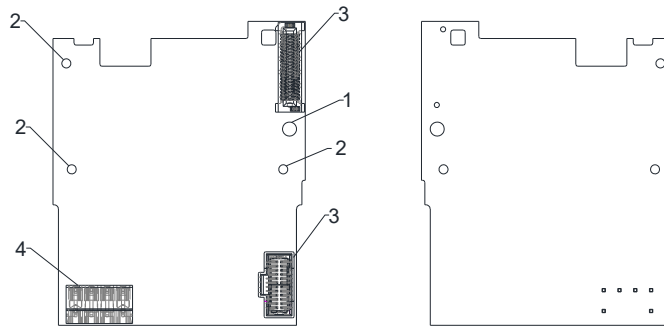
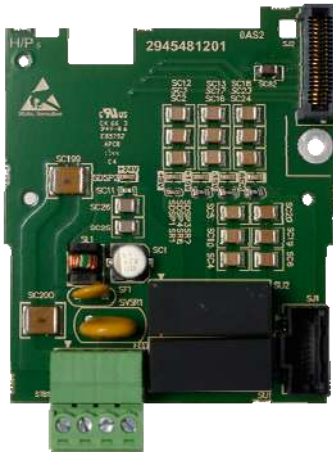

1. Screw fixing hole
2. Positioning hole
3. AC motor drive connection port
4. +24 V terminal block

■ Features

1. Provides external power supply.
2. Supports external 24 V_{DC} input.
3. Supports reading and writing parameter and status monitoring of the drive.

■ Specifications

When the drive is only powered by the EMC-BPS01, communication remains normal, including support for all communication cards and the following functions:

- Reading and writing parameters
- Display with keypad
- Keypad buttons (except the RUN button)
- Analog input, can be used with +10 V terminal to supply the power.
- Multi-function inputs (FWD, REV, MI1–MI8), can be used with +24 V terminal or an external power supply.
- Relay output available
- Pulse sequence frequency command function

The following functions are not supported:

- DFM digital frequency signal output
- AFM multi-function analog voltage output
- PLC function

8-8 Delta Bus Standard Wire

Delta Bus Standard Wire	Model Name	Description	Length
CANopen / Digital keypad RJ45 extension lead	UC-CMC003-01A	CANopen Communication wire, RJ45 Connector	0.3 m
	UC-CMC005-01A	CANopen Communication wire, RJ45 Connector	0.5 m
	UC-CMC010-01A	CANopen Communication wire, RJ45 Connector	1 m
	UC-CMC015-01A	CANopen Communication wire, RJ45 Connector	1.5 m
	UC-CMC020-01A	CANopen Communication wire, RJ45 Connector	2 m
	UC-CMC030-01A	CANopen Communication wire, RJ45 Connector	3 m
	UC-CMC050-01A	CANopen Communication wire, RJ45 Connector	5 m
	UC-CMC100-01A	CANopen Communication wire, RJ45 Connector	10 m
	UC-CMC200-01A	CANopen Communication wire, RJ45 Connector	20 m
DeviceNet	UC-DN01Z-01A	DeviceNet Communication wire	305 m
	UC-DN01Z-02A	DeviceNet Communication wire	305 m
EtherNet / EtherCAT	UC-EMC003-02A	EtherNet/EtherCAT Communication wire, Shielding	0.3 m
	UC-EMC005-02A	EtherNet/EtherCAT Communication wire, Shielding	0.5 m
	UC-EMC010-02A	EtherNet/EtherCAT Communication wire, Shielding	1 m
	UC-EMC020-02A	EtherNet/EtherCAT Communication wire, Shielding	2 m
	UC-EMC050-02A	EtherNet/EtherCAT Communication wire, Shielding	5 m
	UC-EMC100-02A	EtherNet/EtherCAT Communication wire, Shielding	10 m
	UC-EMC200-02A	EtherNet/EtherCAT Communication wire, Shielding	20 m
PROFIBUS	UC-PF01Z-01A	PROFIBUS DP Communication wire	305 m

Chapter 9 Specification

9-1 230V Series

9-2 460V Series

9-3 Environment for Operation, Storage and Transportation

9-4 Derating for Ambient Temperature and Altitude

9-1 230V Series

230V, one-phase

Frame		A					B			
Model VFD_____SAA		2A8MS21 <input type="checkbox"/>		4A8MS21 <input type="checkbox"/>		7A5MS21MN	7A5MS21MF	11AMS21 <input type="checkbox"/>		
		MN	MF	MN	MF			MN	MF	
Applicable Motor Output (kW)		0.4		0.75		1.5	1.5	2.2		
Applicable Motor Output (HP)		0.5		1		2	2	3		
Output Rating	Heavy Duty	Rated Output Capacity (kVA)		1.1		1.8	2.9	2.9	4.2	
		Rated Output Current (A)		2.8		4.8	7.5	7.5	11	
		Carrier Frequency (kHz)		2-15 (Default: 4)						
	Normal Duty	Rated Output Capacity (kVA)		1.2		1.9	3.2	3.2	4.8	
		Rated Output Current (A)		3.2		5	8.5	8.5	12.5	
		Carrier Frequency (kHz)		2-15 (Default: 4)						
Input Rating	Rated Input Current (A)	Heavy Duty		7.3		10.8	16.5	16.5	24.2	
		Normal Duty		8.3		11.3	18.5	18.5	27.5	
	Rated Voltage / Frequency		One-phase AC 200-240 V, 50/60 Hz							
	Operating Voltage Range (V _{AC})		170-264 (-15-10%)							
	Frequency Range (Hz)		47-63							
Weight (kg)		2.25	2.65	2.6	2.9	3.1	3.95	3.5	4.0	
Cooling Method		Convective cooling					Fan cooling			
EMC Filter		Optional	Built-in	Optional	Built-in	Optional	Built-in	Optional	Built-in	
IP Rating		IP66 / NEMA 4X								

 **NOTE**

- The value of the carrier frequency is set in the factory. To increase the carrier frequency, decrease the current. See the derating curve diagram for Pr.06-55 for more information.
- When the load is a shock or impact load, use a higher level model.

230V, three-phase

Frame		A			B		C	
Model VFD_____SAA		2A8MS23MN	4A8MS23MN	7A5MS23MN	11AMS23MN	17AMS23MN	25AMS23MN	
Applicable Motor Output (kW)		0.4	0.75	1.5	2.2	3.7	5.5	
Applicable Motor Output (HP)		0.5	1	2	3	5	7.5	
Output Rating	Heavy Duty	Rated Output Capacity (kVA)	1.1	1.8	2.9	4.2	6.5	9.5
		Rated Output Current (A)	2.8	4.8	7.5	11	17	25
		Carrier Frequency (kHz)	2–15 (Default: 4)					
	Normal Duty	Rated Output Capacity (kVA)	1.2	1.9	3.0	4.8	7.4	10.3
		Rated Output Current (A)	3.2	5	8	12.5	19.5	27
		Carrier Frequency (kHz)	2–15 (Default: 4)					
Input Rating	Rated Input Current (A)	Heavy Duty	3.4	5.8	9.0	13.2	20.4	30
		Normal Duty	3.8	6.0	9.6	15	23.4	32.4
	Rated Voltage / Frequency		Three-phase AC 200–240 V, 50/60 Hz					
	Operating Voltage Range (V _{AC})		170–264 (-15–10%)					
Frequency Range (Hz)		47–63						
Weight (kg)		2.3	2.45	2.75	3.4	3.5	4.25	
Cooling Method		Convective cooling			Fan cooling			
EMC Filter		Optional						
IP Rating		IP66 / NEMA 4X						

 **NOTE**

- The value of the carrier frequency is set in the factory. To increase the carrier frequency, decrease the current. See the derating curve diagram for Pr.06-55 for more information.
- When the load is a shock or impact load, use a higher level model.

9-2 460V Series

460V, three-phase

Frame			A						B			
Model VFD_____ SAA			1A5MS43 <input type="checkbox"/>		2A7MS43 <input type="checkbox"/>		4A2MS43 <input type="checkbox"/>		5A5MS43MN	5A5MS43MF	9A0MS43 <input type="checkbox"/>	
			<input type="checkbox"/> MN	<input type="checkbox"/> MF	<input type="checkbox"/> MN	<input type="checkbox"/> MF	<input type="checkbox"/> MN	<input type="checkbox"/> MF			<input type="checkbox"/> MN	<input type="checkbox"/> MF
Applicable Motor Output (kW)			0.4		0.75		1.5		2.2		3.7	
Applicable Motor Output (HP)			0.5		1		2		3		5	
Output Rating	Heavy Duty	Rated Output Capacity (kVA)	1.1		2.1		3.2		4.2		6.9	
		Rated Output Current (A)	1.5		2.7		4.2		5.5		9	
		Carrier Frequency (kHz)	2–15 (Default: 4)									
	Normal Duty	Rated Output Capacity (kVA)	1.4		2.3		3.5		5.0		8.0	
		Rated Output Current (A)	1.8		3		4.6		6.5		10.5	
		Carrier Frequency (kHz)	2–15 (Default: 4)									
Input Rating	Rated Input Current (A)	Heavy Duty	2.1		3.7		5.8		6.1		9.9	
		Normal Duty	2.5		4.2		6.4		7.2		11.6	
	Rated Voltage / Frequency		Three-phase AC 380–480 V, 50/60 Hz									
	Operating Voltage Range (V _{AC})		323–528 (-15–10%)									
Frequency Range (Hz)		47–63										
Weight (kg)			2.35	2.65	2.6	2.8	2.8	3.1	3.6	3.8	3.45	3.95
Cooling Method			Convective cooling						Fan cooling			
EMC Filter			Optional	Built-in	Optional	Built-in	Optional	Built-in	Optional	Built-in	Optional	Built-in
IP Rating			IP66 / NEMA 4X									

Frame			C					
Model VFD_____ SAA			13AMS43 <input type="checkbox"/>			17AMS43 <input type="checkbox"/>		
			<input type="checkbox"/> MN	<input type="checkbox"/> MF	<input type="checkbox"/> MN	<input type="checkbox"/> MF	<input type="checkbox"/> MN	<input type="checkbox"/> MF
Applicable Motor Output (kW)			5.5			7.5		
Applicable Motor Output (HP)			7.5			10		
Output Rating	Heavy Duty	Rated Output Capacity (kVA)	9.9			13		
		Rated Output Current (A)	13			17		
		Carrier Frequency (kHz)	2–15 (Default: 4)					
	Normal Duty	Rated Output Capacity (kVA)	12			15.6		
		Rated Output Current (A)	15.7			20.5		
		Carrier Frequency (kHz)	2–15 (Default: 4)					
Input Rating	Rated Input Current (A)	Heavy Duty	14.3			18.7		
		Normal Duty	17.3			22.6		
	Rated Voltage / Frequency		Three-phase AC 380–480 V, 50/60 Hz					
	Operating Voltage Range (V _{AC})		342–528 (-15–10%)					
Frequency Range (Hz)		47–63						
Weight (kg)			4.25	4.95	4.25	5.05		
Cooling Method			Fan cooling					
EMC Filter			Optional	Built-in	Optional	Built-in		
IP Rating			IP66 / NEMA 4X					

 **NOTE**

- The value of the carrier frequency is set in the factory. To increase the carrier frequency, decrease the current. See the derating curve diagram for Pr.06-55 for more information.
- When the load is a shock or impact load, use a higher level model.

General Specifications

Control Characteristics	Control Method	V / F, VFPG*1, SVC, FOC sensorless		
	Applied Motor	IM (Induction Motor), Simple PM control (IPM and SPM)		
	Max. Output Frequency	0.00–599.00 Hz		
	Starting Torque*2	150 % / 3 Hz	V / F, SVC control for IM, Heavy duty	
		200 % / 0.5 Hz	FOC control for IM, Heavy duty	
		100 % / (1/20 of motor rated frequency)	SVC control for PM, Heavy duty	
	Speed Control Range*2	1 : 50	V / F, SVC control for IM, Heavy duty	
		1 : 100	FOC control for IM, Heavy duty	
		1 : 20	SVC control for PM, Heavy duty	
	Overload Capability	Normal duty: 120 % 60 sec., 150 % 3 sec. Heavy duty: 150 % 60 sec., 200 % 3 sec.		
Frequency Setting Signal	0–10 V / -10–10 V 4–20 mA / 0–10 V 1 channel pulse input (33 kHz), 1 channel pulse output (33 kHz).			
Main Function	Multiple motor switches (maximum four independent motor parameter settings), Fast start-up, Deceleration Energy Back (DEB) function, Wobble frequency function, Fast deceleration function, Master and Auxiliary frequency source selectable, Momentary power loss ride thru, Speed search, Over-torque detection, Torque limit, 16-step speed (max.), Accel./decel. time switch, S-curve accel./decel., three-wire sequence, JOG frequency, Upper/lower limits for frequency reference, DC injection braking at start and stop, PID control, Built-in PLC (2K steps), Positioning function			
Application Macro	Built-in application parameter groups (selected by industry) and user-defined application parameter groups.			
Protection Characteristics	Motor Protection	Over-current, Over-voltage, Over-temperature, Phase loss		
	Stall Prevention	Stall prevention during acceleration, deceleration and running (independent settings)		
Accessory	Communication Cards	DeviceNet, EtherCAT, EtherNet/IP, PROFIBUS DP, Modbus TCP, CANopen		
	External DC Power Supply	EMM-BPS01 (DC 24 V power supply card)		
Certifications		CE, RCM, REACH, RoHS, TUV, UL		

*1 Pulse input (MI7 terminal) is used as speed feedback.

*2 Control accuracy may vary depending on the environment, application conditions or different motors. For details, contact our company or your local distributor.

9-3 Environment for Operation, Storage and Transportation

Do not place the drive in a critical environment, such as direct contact with chemical substance and solvent, and exposure to direct sunlight.				
Environment	Installation Location	PCB design is compliant with IEC 60364-1 / IEC 60664-1 Pollution Degree 2. The outer case meets IP66 standard for indoor use. If the drive is for outdoor application, avoid direct sunlight.		
	Surrounding Temperature	Operation	IP66 / NEMA 4X / UL Type 4X	-20–40 °C -20–50 °C with derating
		Storage	-40–85 °C	
		Transportation	-20–70 °C	
		Non-condensing, non-freezing		
	Relative Humidity	Operation	0–100 %	
		Storage / Transportation	Max. 95 %	
		No condense water		
	Air Pressure	Operation	86–106 kPa	
		Storage / Transportation	70–106 kPa	
	Pollution Level	IEC 60721-3		
		Operation	Class 3C2; Class 3S2	
		Storage	Class 2C2; Class 2S2	
		Transportation	Class 1C2; Class 1S2	
Concentrate prohibited				
Altitude	< 1000 m (> 1000 m with derating)			
Package Drop	Storage	ISTA procedure 1A (according to weight) IEC 60068-2-31		
	Transportation			
Vibration	Operating	1.0 mm, peak to peak value range from 2–13.2 Hz; 0.7–2.0 G range from 13.2–55 Hz; 2.0 G range from 55–512 Hz; complies with IEC 60068-2-6.		
	Non-operating	2.5 G peak 5 Hz–2 kHz 0.015" maximum displacement		
Impact	Operating	15 G, 11 ms; complies with IEC / EN 60068-2-27.		
	Non-operating	30 G		

9-4 Derating for Ambient Temperature and Altitude

- Derating for Ambient Temperature

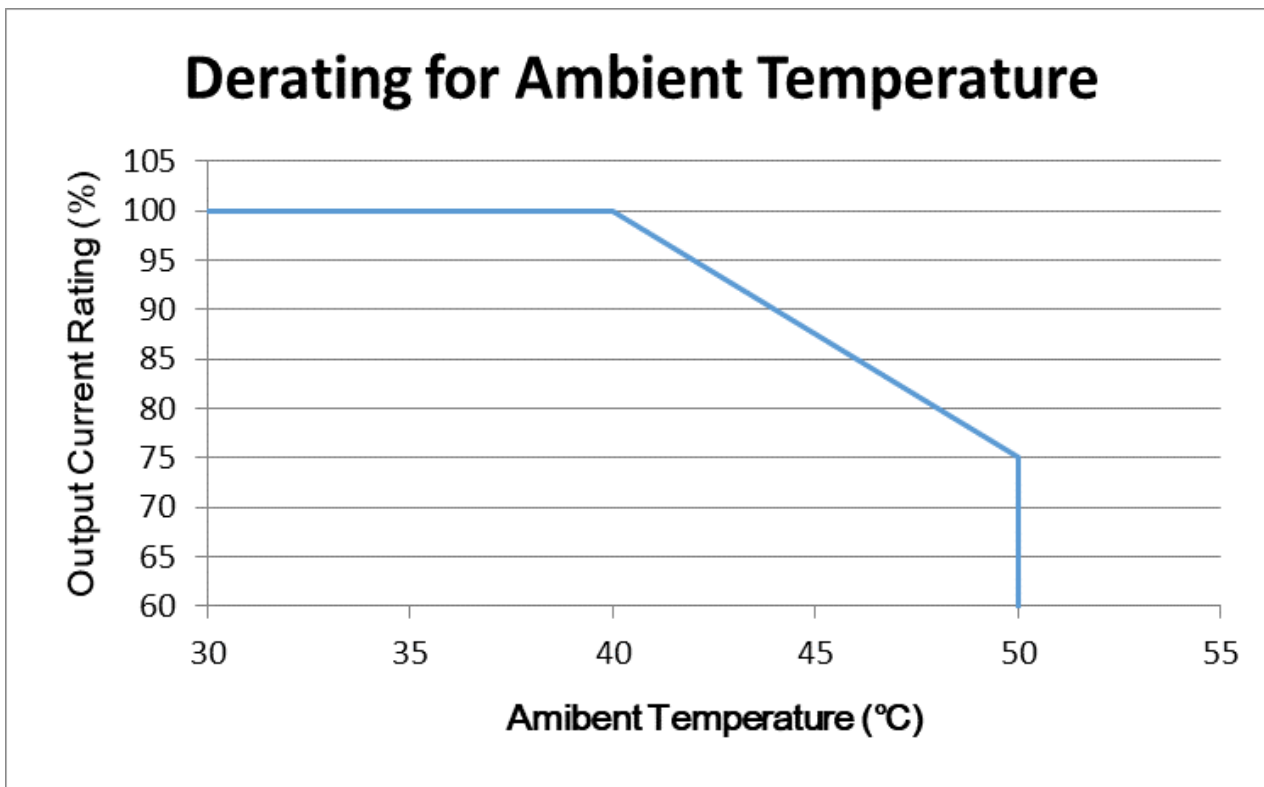

- Derating for Altitude

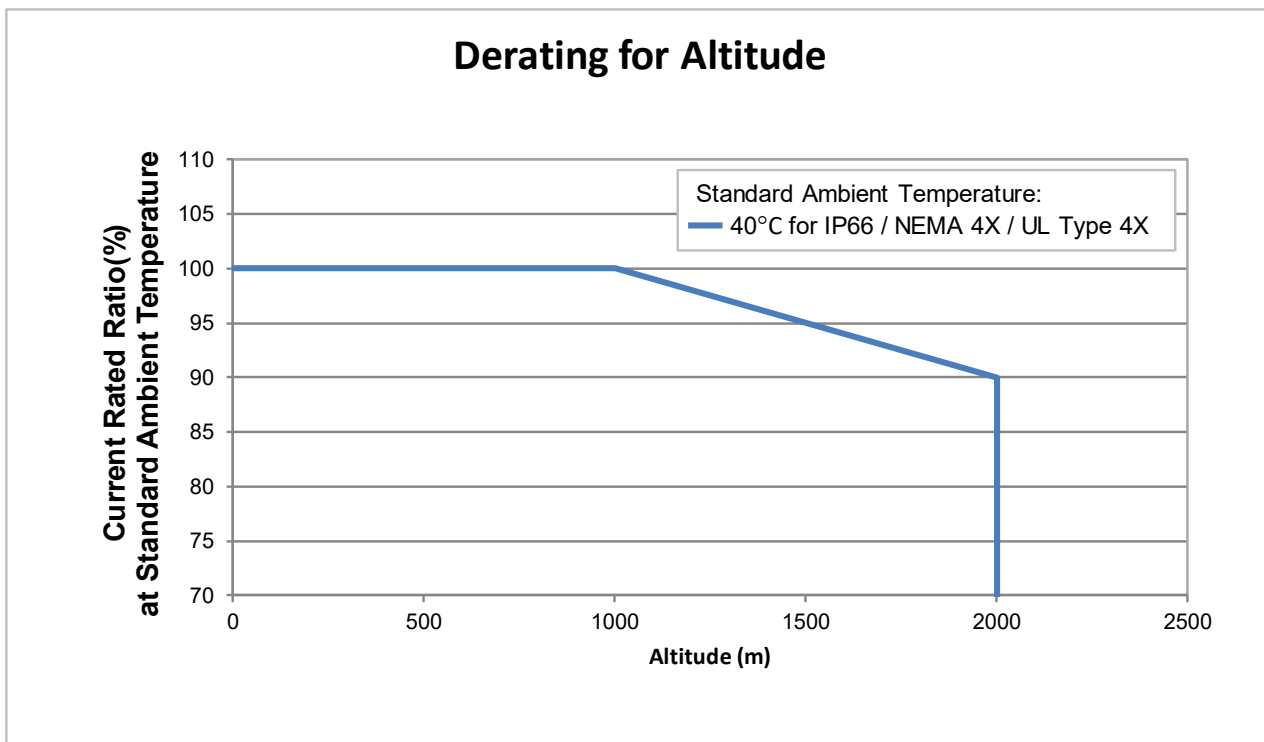

For IP66 / NEMA 4X / UL Type 4X

Current derating at ambient temperature			
Ambient temperature	40 °C	45 °C	50 °C
Operating altitude above sea level (m)	0–1000	100 %	
	1001–1500	100 %	95 %
	1501–2000	100 %	95 %

Operating Conditions	Ambient Temperature Limits
IP66 / NEMA 4X / UL Type 4X	When the AC motor drive is operating at the rated current, the ambient temperature must be between -20–40 °C. When the temperature is over 40 °C, for every increase by 1 °C, decrease the rated current 2.5 %. The maximum allowable temperature is 50 °C.
High Altitude	If the AC motor drive is installed at an altitude of 0–1000 m, follow normal operation restrictions. If it is installed at an altitude of 1000–2000 m, decrease the rated current by 1 % or lower the temperature 0.5 °C for every 100 m increase in altitude. The maximum altitude for corner grounded is 2000 m. Contact Delta for more information if you need to use this motor drive at an altitude of 2000 m or higher.

Chapter 10 Digital Keypad

Keyboard Panel Appearance

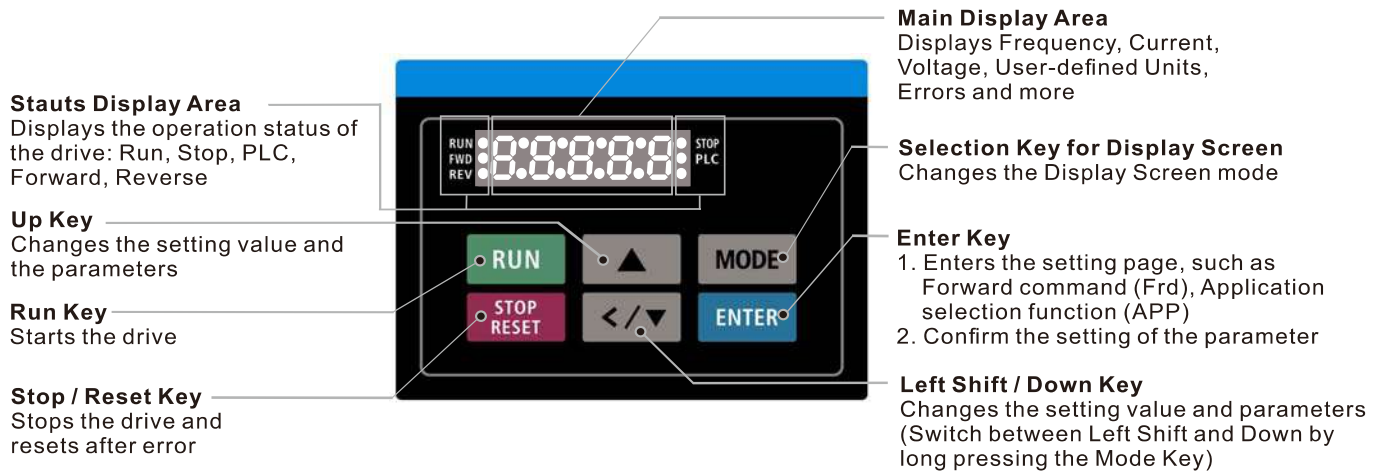

Descriptions of Keypad Functions

Displayed items	Descriptions
RUN ● STOP FWD ● PLC REV ● 	Displays the present frequency setting for the drive.
RUN ● STOP FWD ● PLC REV ● 	Displays the actual output frequency to the motor.
RUN ● STOP FWD ● PLC REV ● 	Displays the user-defined output of a physical quantity. This example is for parameter Pr.00-04 = 30.
RUN ● STOP FWD ● PLC REV ● 	Displays the load current.
RUN ● STOP FWD ● PLC REV ● 	Forward command
RUN ● STOP FWD ● PLC REV ● 	Reverse command
RUN ● STOP FWD ● PLC REV ● 	Displays the count value.
RUN ● STOP FWD ● PLC REV ● 	Displays a parameter item.
RUN ● STOP FWD ● PLC REV ● 	Displays a parameter value.
RUN ● STOP FWD ● PLC REV ● 	Displays an external fault.
RUN ● STOP FWD ● PLC REV ● 	Displays the data that has been accepted and automatically stored in the internal memory.

Displayed items	Descriptions
<p>RUN ● FWD ● REV ●</p> <p>Err</p> <p>● STOP ● PLC</p>	Displays the data set that is not accepted or has exceeded the value.

Keypad Operation Process

A. Main Page Selection

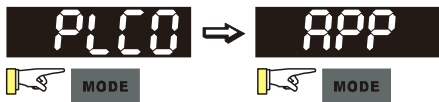

Point 1: In screen selection mode **ENTER** enter to set parameter

Point 2: App displayed only when Pr.13-00≠0

Setting parameters



Note: In the parameter setting mode, you can press **ENTER** to return the selecting mode.

To shift data

START



Setting direction

(When operation source is digital keypad)

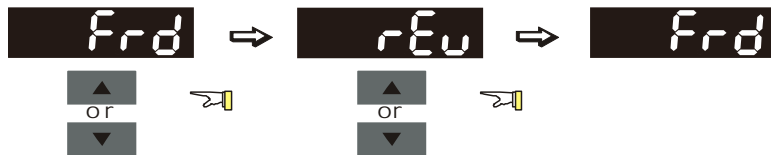

PLC Setting

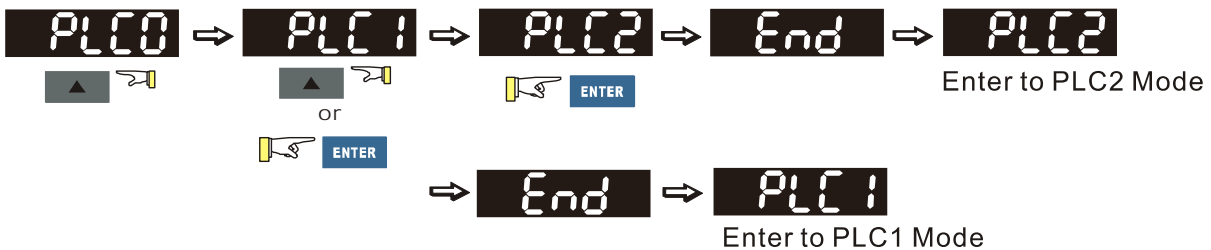

B. F Page (Frequency command setting page)

General Mode 1

(maximum operation frequency Pr.01-00 is 2 digits; for example, Pr.01-00 = 60.00 Hz)

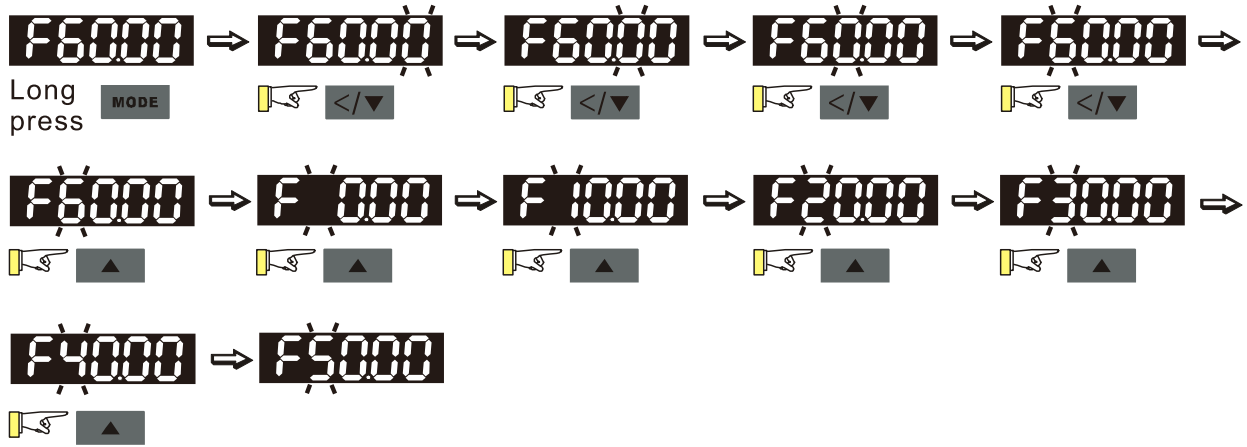

General Mode 2

(maximum operation frequency Pr.01-00 is 3 digits; for example, Pr.01-00 = 599.0 Hz)

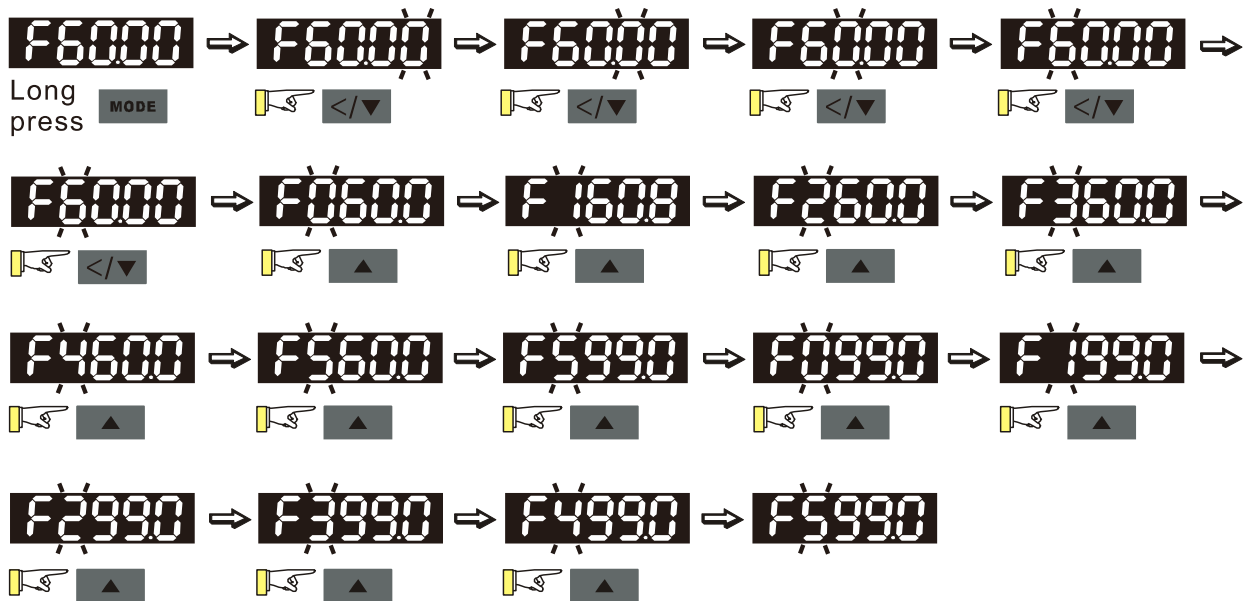

C. Application Selection Page

The Application Selection page displays “APP”, but does not show the APP page when Pr.13-00 = 0.

The description of Pr.13-00 setting is as follows:

Pr.13-00 = 0

The application selection is inactive and does not show on the display.

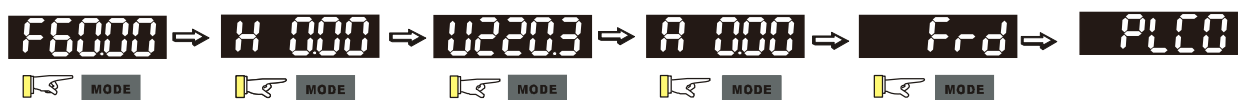

Pr.13-00 = 1 specifies a user-defined application, and the keypad displays “USER”.

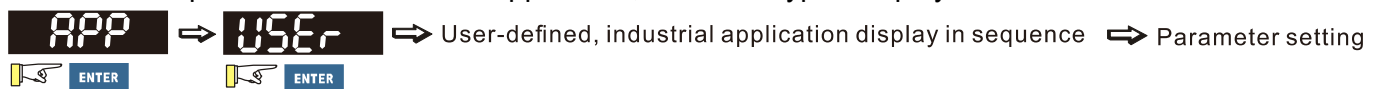

Pr.13-00 = 2 specifies the Compressor application, and the keypad displays “CoPr”.

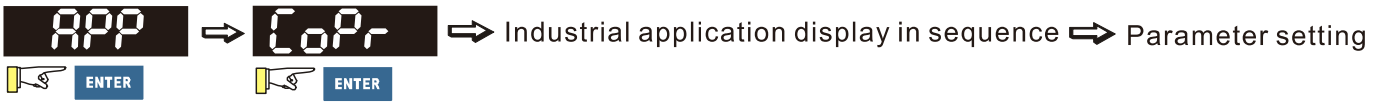

Pr.13-00 = 3 specifies the Fan application, and the keypad displays “FAn”.

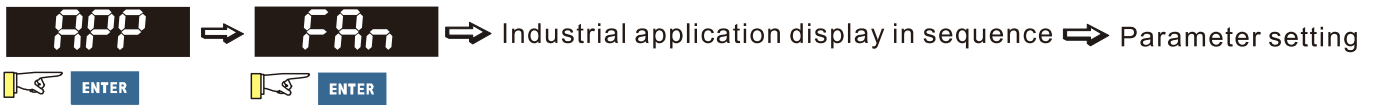

Pr.13-00 = 4 specifies the Pump application, and the keypad displays “PUMP”.

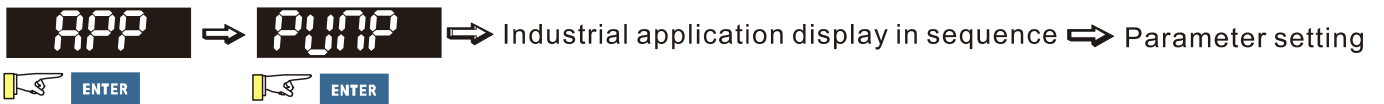

Pr.13-00 = 5 specifies the Conveyor application, and the keypad displays “CnYr”.

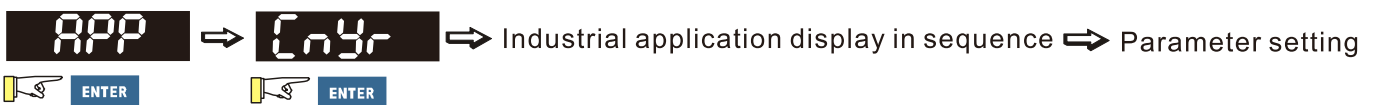

Pr.13-00 = 6 specifies the Machine Tool application, and the keypad displays “CnC”.

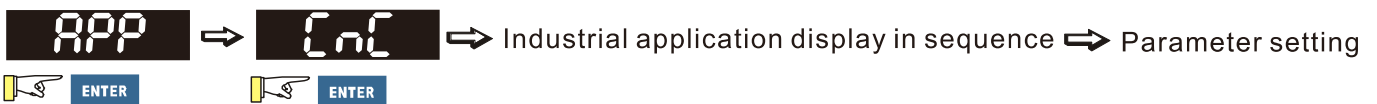

Pr.13-00 = 7 specifies the Packing application, and the keypad displays “PAC”.

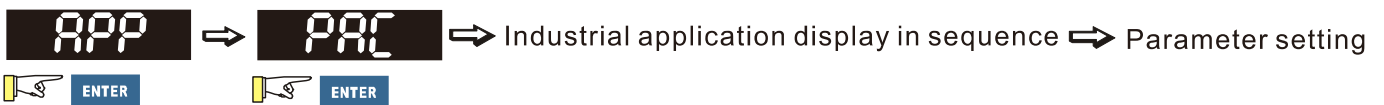

Pr.13-00 = 8 specifies the Textile application, and the keypad displays “tiLE”.

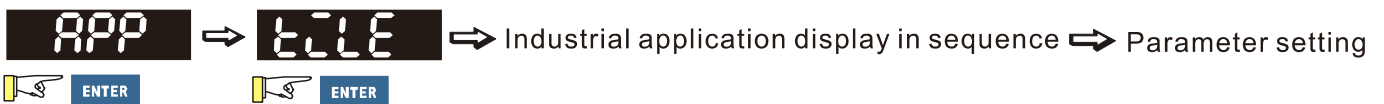

When Pr.13-00 is not 0, the corresponding parameters appear in the APP page according to the setting for Pr.13-00. In each selected application, you can view the parameters by pressing ENTER button. If Pr.13-00 = 1 and you do not set any parameters in Pr.13-01–13-50, you cannot enter the sub-layer of the USER page. The parameter settings in the APP page are the same as those in other parameter groups: use UP and LEFT/DOWN key to set the parameter’s value.

Follow the process below to set the user-defined application selection (Pr.13-00 = 1).

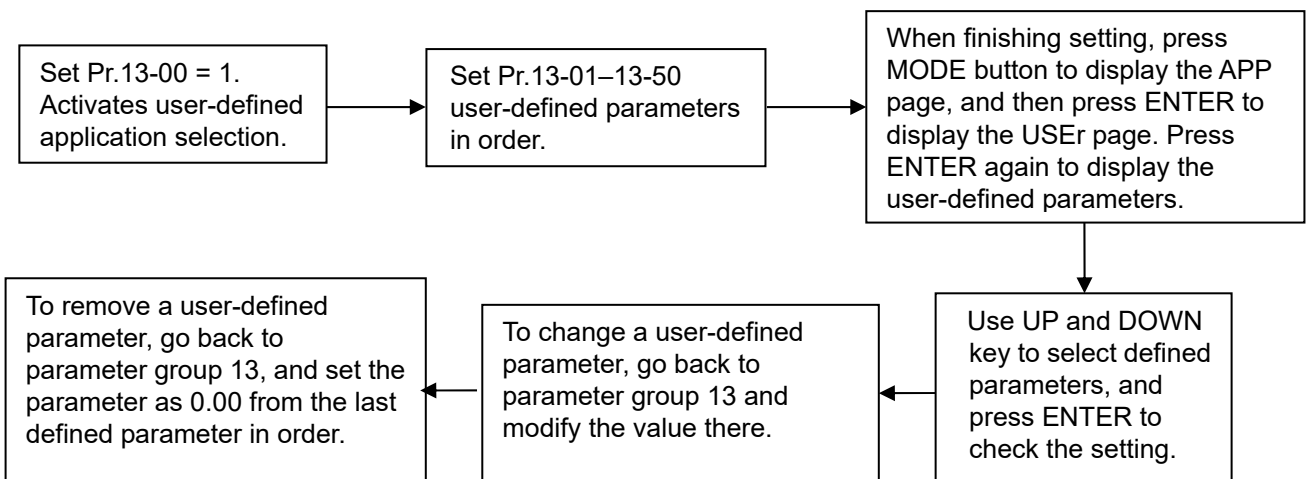

1. Activate the application selection by setting Pr.13-00.
2. After setting Pr.13-00 = 1, you can enter the definitions for Pr.13-01–50.
3. The default setting for Pr.13-01–50 is P 0.00. Press ENTER to set the corresponding parameters for Pr.13-01–50 in sequence.
4. Setting the corresponding parameters for Pr.13-01–50 is the same as those in other parameter groups: use UP and LEFT/DOWN key to select and set the parameter's value.
Note 1: you cannot set values for read-only parameters.
Note 2: you must set Pr.13-01, 02.....50 in sequence, or the display shows "Err".
5. To change the corresponding parameters, go back to Pr.13-01–50 to modify.
6. After setting, to remove a set parameter, set from the last parameter (set to 0.00) first, or the display shows "Err". For example, if there are 5 user-defined parameters (Pr.13-01, 13-02...13-05), to remove Pr.13-02, you must remove Pr.13-05 first, then 13-04, then 13-03, and then 13-02.
7. When you finish the setting, press MODE to go back to the APP page, and then press ENTER again. The Keypad displays "USER". After you press ENTER again, the corresponding parameter that you set appears.

Follow the process below to set specific application selection (Pr.13-00 = 2–8).

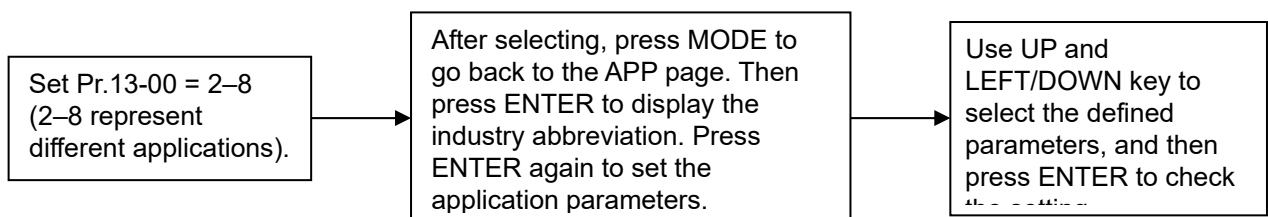

D. Parameter Setting

D-1. Unsigned Parameter

(Parameter setting range ≥ 0 ; for example: Pr.01-00)

1. Without using the left shift key: use UP and LEFT/DOWN key to select and adjust the parameters. Press ENTER after setting to the required value.
2. Using the left shift key: After you press the left shift key, the last digit starts to blink. Press the left shift key to move the blinking cursor to the digit to adjust, and increase the value by pressing the UP key. The value goes back to 0 after 9.
3. Press LEFT/DOWN key to shift the blinking cursor one digit to the left and increase the value by pressing the UP key.
4. After you finish setting the parameter, the left shift key function is not disabled automatically until you disable it manually.

For example: the default setting for Pr.01-00 is 60.00. Pressing the MODE key for > 2 seconds enables the left shift function. The procedure for pressing the LEFT/DOWN key shows as follows:

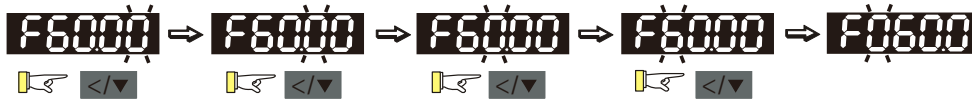

The upper limit for Pr.01-00 is 599.00. If you set a value greater than 599.00, “Err” appears after you press ENTER, and then the keypad shows the upper limit (599.00) for a second to remind you of the incorrect setting. The setting value remains as the original set value (default is 60.00) and the cursor returns to the last digit.

D-2. Signed Parameter Setting Status 1

(Parameter setting range can be smaller than 0; for example: Pr.03-03)

1. Without using the left shift key: use UP and LEFT/DOWN key to select and adjust the parameters. Press ENTER after setting to the required value.
2. Using the left shift key: After you press the MODE key for >2 seconds, the last digit starts to blink. Press the left shift key to move the blinking cursor to the digit to adjust, and increase the value by pressing the UP key. The value goes back to 0 after 9.
3. Press LEFT/DOWN key to shift the blinking cursor one digit to the left. When you shift to the first digit and press the UP key, the digit “0” changes to “-” (minus).
4. After you finish setting the parameter, the left shift key function is not disabled automatically until you disable it manually.

For example: the default setting for Pr.03-03 is 0.0. Pressing the MODE key for > 2 seconds enables the left shift function. The procedure for pressing the LEFT/DOWN key shows as follows:

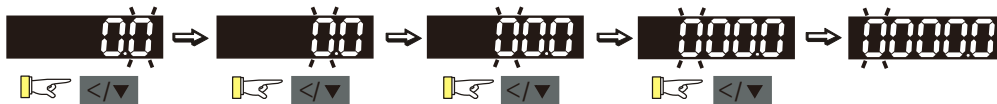

The upper limit for Pr.03-03 is 100.0 and lower limit is -100.0. If the value is more than 100.0 or less than -100.0, “Err” appears after you press ENTER, and then the keypad shows the upper limit (100.0) or lower limit (-100.0) for a second to remind you of the incorrect setting. The setting value remains as the original set value (0.0), and the cursor returns to the last digit.

D-3. Signed Parameter Setting Status 2

(The parameter setting range can be smaller than 0 and the lower limit should be \leq -100.00 with two decimal places; for example: Pr.03-74)

1. Without using the left shift key: use UP and LEFT/DOWN key to select and adjust the parameters. Press ENTER after setting to the required value.
2. Using the left shift key: After pressing the MODE key for >2 seconds, the last digit starts to blink. Press the left shift key to move the blinking cursor to the digit to adjust, and increase the value by pressing the UP key. The value goes back to 0 after 9.
3. Press the LEFT/DOWN key to shift the blinking cursor one digit to the left. When you shift to the first digit and press the UP key, the digit “0” changes to “-” (minus).
4. For parameters in three digits and two decimal places with both positive and negative setting values (Pr.03-74, -100.00 %–100.00 %), it only displays values in four digits (100.0 or -100.0). For example: the default setting for Pr.03-74 is -100.0. If you increase the value by 0.001, it displays -99.99.

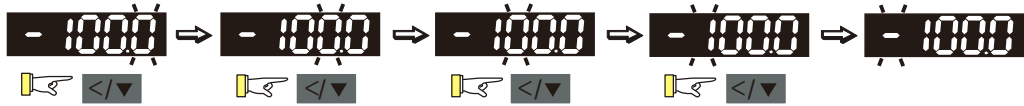

The upper limit for Pr.03-74 is 100.00 and lower limit is -100.00. If you set a value of more than 100.0 or less than -100.0 when the left shift function key is enabled, “Err” appears after you press ENTER, and then the keypad temporarily shows the upper limit (100.0) or lower limit (-100.0) (only one decimal) to remind you of the incorrect setting. The setting value remains as the original set value, which means the parameter is not changed. Finally, the cursor returns to the last digit.

Reference Table for the 7-segment Digital Keypad LED Display

Number	0	1	2	3	4	5	6	7	8	9
Display	0	1	2	3	4	5	6	7	8	9
Number	A	a	B	b	C	c	D	d	E	e
Display	A	-	-	b	C	c	-	d	E	-
Number	F	f	G	g	H	h	I	i	J	j
Display	F	-	G	-	H	h	-	i	J	j
Number	K	k	L	l	M	m	N	n	O	o
Display	K	-	L	-	-	-	-	n	-	o
Number	P	p	Q	q	R	r	S	s	T	t
Display	P	-	-	Q	-	r	S	-	-	t
Number	U	u	V	v	W	w	X	x	Y	y
Display	U	u	-	v	-	-	-	-	Y	-
Number	Z	z								
Display	Z	-								

[This page intentionally left blank]

11 Summary of Parameter Settings

- All parameters and setting values in MS300 (standard models) series are applicable for those in MS300 (IP66 / NEMA 4X) series except the following. Refer to Chapter 11 in MS300 (standard models) series for the rest of parameter settings.
 1. Pr.00-20, setting value is 7
 2. Pr.00-30, setting value is 7
 3. Pr.03-39
 4. Pr.03-40
 5. Pr.03-41
 6. Pr.03-42
 7. Pr.03-43

- Download the MS300 (standard models) series user manual at: 

12 Description of Parameter Settings

- All parameters and setting values in MS300 (standard models) series are applicable for those in MS300 (IP66 / NEMA 4X) series except the following. Refer to Chapter 12 in MS300 (standard models) series for the rest of parameter settings.

Download the MS300 (standard models) series user manual at: 

1. Pr.00-20, setting value is 7
2. Pr.00-30, setting value is 7
3. Pr.03-39
4. Pr.03-40
5. Pr.03-41
6. Pr.03-42
7. Pr.03-43
8. Pr.06-55: slightly different from that for MS300 (standard models) series. See below for the difference:

06-55 Derating Protection

Default: 0

- Settings
- 0: Constant rated current and limit carrier wave by load current and temperature
 - 1: Constant carrier frequency and limit load current by setting carrier wave
 - 2: Constant rated current (same as setting 0), but close current limit

 Allowable maximum output frequency and the minimum carrier wave limit in control mode:
VF、SVC、VFPG

When the maximum output frequency is 599 Hz, the minimum carrier wave is 6 k.

 Setting 0:

When the operating point is greater than the derating curve (when the operating carrier wave is greater than the rated carrier wave), the rated current is constant, and carrier frequency (Fc) output by the drive decreases automatically according to the ambient temperature, overload output current and overload time. If overloads are not frequency, and the concern is only about the carrier frequency operating with the rated current for a long time, and changes to the carrier wave due to short overload are acceptable, set to 0.

Refer to the following diagram for the level of carrier frequency. Take VFD9A0MS43MNSAA in normal duty for example: ambient temperature 50°C, 100 % duty, UL open-type, and independent installation. When the carrier frequency is set to 10 kHz, it corresponds to 55 % of the rated output current; under the same conditions which mentioned above but the ambient temperature 40°C, it corresponds to 75 % of the rated output current. When the output current is higher than this value, it automatically decreases the carrier wave according to the ambient temperature, output current and overload time.

Setting 1:

When the operating point exceeds derating curve 1, the carrier frequency is fixed to the set value. Select this mode if the change of carrier wave and motor noise caused by ambient temperature and frequenct overload are not acceptable. Rever to Pr.00-17.

Refer to the following diagram for the derating level of the rated current. Take VFD9A0MS43MNSAA in normal duty for example, when the carrier frequency is to be maintained at 10 kHz, the rated current decreases to 55%. The OL protection executes when the current is $120\% \times 55\% = 66\%$ for one minute; therefore, it must operate by the curve to keep the carrier frequency.

Setting 2:

The protection method and action are the same as setting it to 0, but this disables the current limit when output current is the derating ratio x 120% (default value) in normal duty and is the derating ratio x 180% (default value) in heavy duty.

The advantage is that this can provide a higher starting output current when the carrier frequency setting is higher than the defult. The disadvantage is that the carrier wave derates easily when it overloads.

Example:

When Pr.06-55 = 0 or 1, the over-current stall prevention level = ratio x Pr.06-03. When Pr.06-55 = 2, the over-current stall prevention level = Pr.06-03.

Use with the settings for Pr.00-16 and Pr.00-17.

The ambient temperature also affects the derating; refer to ambient temperature derating curve.

Example:

Take VFD9A0MS43MNSAA in normal duty for example: ambient temperature 50°C, UL open-type, and independent installation. When the carrier frequency is set to 10 kHz, it corresponds to 55% of the rated output current. The ambient temperature 50°C corresponds to 55% x 75% of the rated output current.

You can adjust the derating curve modulation mode (when Pr.00-10 = 0 and Pr.00-11 = 0–3) with Pr.11-41.

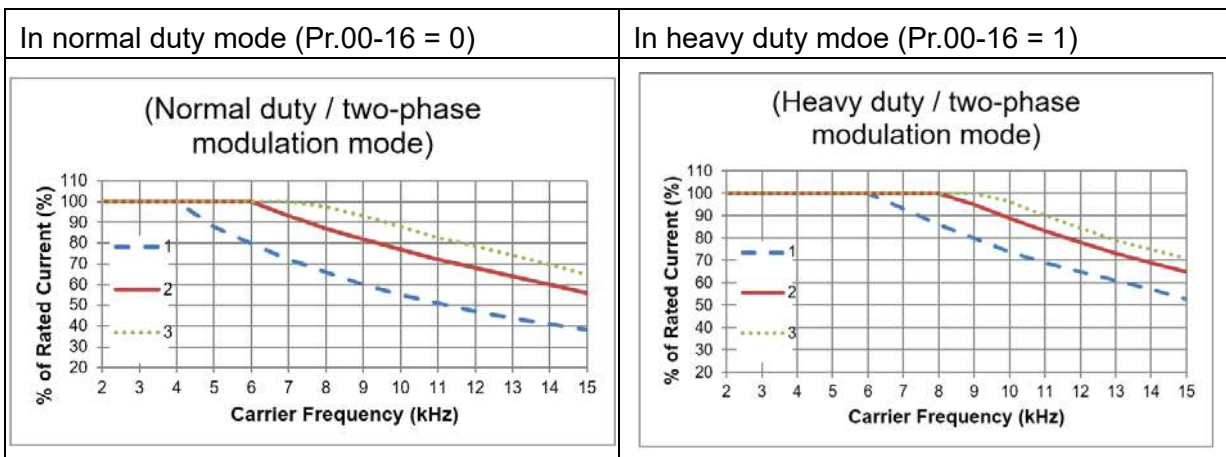

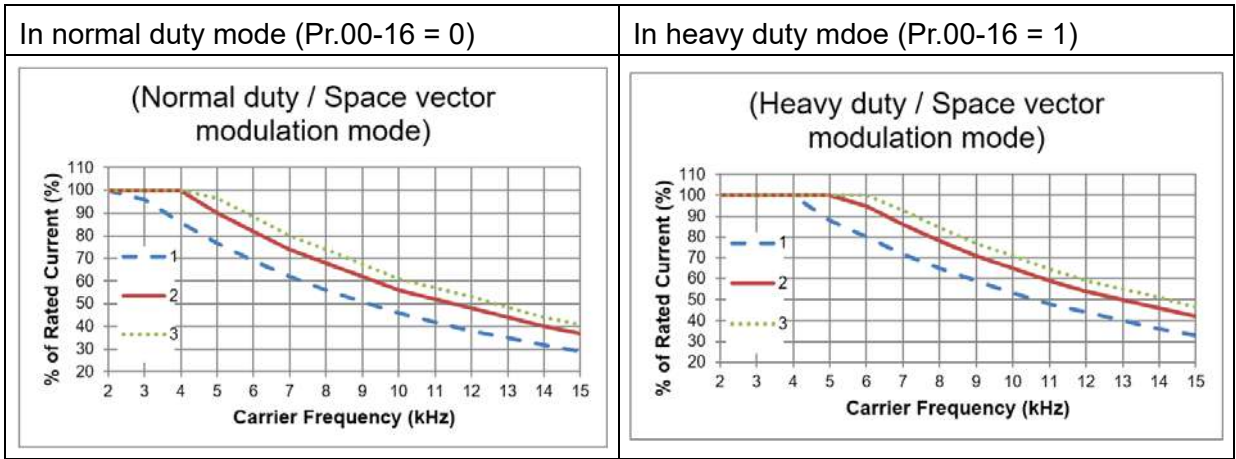

- NOTE** Line 1: $T_a = 40^\circ\text{C}$ / Duty = 100%
 Line 2: $T_a = 40^\circ\text{C}$ / Duty = 75% or $T_a = 30^\circ\text{C}$ / Duty = 100%
 Line 3: $T_a = 40^\circ\text{C}$ / Duty = 50% or $T_a = 25^\circ\text{C}$ / Duty = 100%

Ambient temperature derating curve for general control

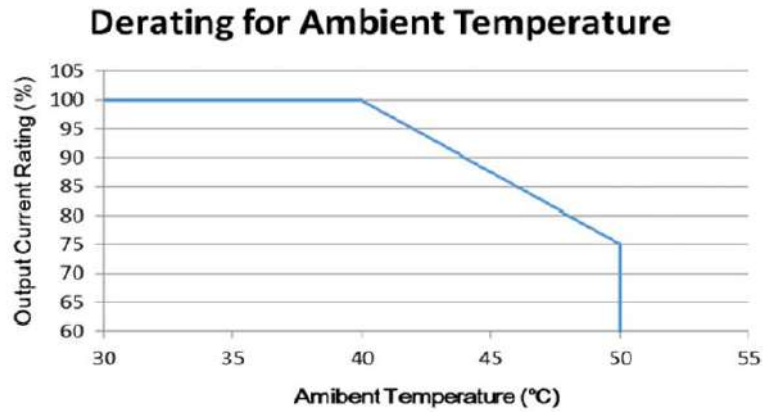

13 Warning Codes

- Refer to Chapter 13 in MS300 (standard models) series for the information. Download the MS300 (standard models) series user manual at: 

14 Error Codes

- Refer to Chapter 14 in MS300 (standard models) series for the information. Download the MS300 (standard models) series user manual at: 

15 CANopen Overview

- Refer to Chapter 15 in MS300 (standard models) series for the information. Download the MS300 (standard models) series user manual at: 

16 PLC Function Applications

- Refer to Chapter 16 in MS300 (standard models) series for the information. Download the MS300 (standard models) series user manual at: 

17 Safe Torque Off Function

- Refer to Chapter 17 in MS300 (standard models) series for the information. Download the MS300 (standard models) series user manual at : 