



■ Features

- 150~1500Vdc 10:1 ultra - wide input range
- 57mm slim width
- 4KVac I/O high isolation(Reinforced isolation)
- Protections: Short circuit / Overload / Over voltage / Over temperature
DC input under voltage / DC input reverse polarity
- Fanless design, cooling by free air convection
- Can be installed on DIN rail TS-35/7.5 or 15
- -30~+80°C ultra-wide operating temperature (> +55°C derating)
- Over voltage category II
- Operating altitude up to 5000 meters
- DC OK relay contact
- DC output voltage adjustable(+20%)
- Full encapsulated
- 3 years warranty

■ Applications

- Photovoltaic power generation
- Renewable energy system
- High voltage frequency conversion
- Industrial control system
- Semiconductor fabrication equipment
- Electro-mechanical apparatus
- DC bus centralized application
- Energy storage system(ESS)
- Charging pile
- Third rail

■ GTIN CODE

MW Search: <https://www.meanwell.com/serviceGTIN.aspx>

■ Description

DDRH-60 series is a 150 ~ 1500Vdc high reliable ultra-high input DIN rail type DC-DC converter which can supply stable working voltage for the load. It is suitable to be mounted on TS-35/7.5 or TS-35/15 rails. Main features are as following: easy to install DIN rail type, narrow width(57mm) in slim design, -30~+80°C wide range operating temperature, 4KVAC high isolation voltage, operation at 5000m altitude, high efficiency, low ripple & noise, complete protections and so on.

DDRH-60 is compliant with UL1741 and BS EN/EN61000-6-2 standard regarding immunity for industrial environments. It is suitable for industrial automation, surveillance, telecommunication and can be widely deployed in the applications of new energy generation such as solar power, and windmill power generation, for instances, photovoltaic power systems, high voltage inverting, DC bus centralized application and so forth.

■ Model Encoding

DDRH - 60 - 24

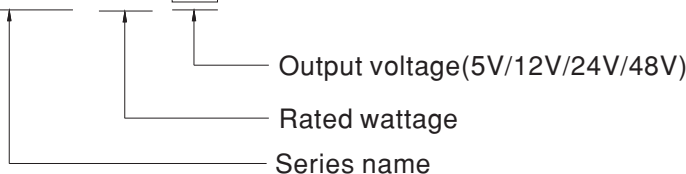



SPECIFICATION

MODEL		DDRH-60-5	DDRH-60-12	DDRH-60-24	DDRH-60-48	
OUTPUT	DC VOLTAGE	5V	12V	24V	48V	
	RATED CURRENT	10A	5A	2.5A	1.25A	
	CURRENT RANGE	0 ~ 10A	0 ~ 5A	0 ~ 2.5A	0 ~ 1.25A	
	RATED POWER	50W	60W	60W	60W	
	RIPPLE & NOISE (max.) Note.2	100mVp-p	120mVp-p	150mVp-p	200mVp-p	
	VOLTAGE ADJ. RANGE	5 ~ 6V	12 ~ 15V	24 ~ 29V	48 ~ 54V	
	VOLTAGE TOLERANCE Note.3	± 1.5%	± 1.5%	± 1.0%	± 1.0%	
	LINE REGULATION	± 0.5%	± 0.5%	± 0.5%	± 0.5%	
	LOAD REGULATION	± 1.5%	± 0.5%	± 0.5%	± 0.5%	
EXTERNAL CAPACITANCE LOAD (Max.)	6000 μ F	4000 μ F	2500 μ F	1000 μ F		
INPUT	VOLTAGE RANGE Note.4	150 ~ 1500Vdc				
	EFFICIENCY (Typ.)	200Vdc	80%	83%	86%	87%
		800Vdc	81%	85%	87%	88%
		1500Vdc	76%	81%	84%	83%
INRUSH CURRENT (max.)	COLD START 120A/1500Vdc 80A/800Vdc 30A/150Vdc					
PROTECTION	OVERLOAD	105 ~ 135% rated output power Protection type : Hiccup up mode when output voltage < 55%, recovers automatically after condition is removed; Constant current limiting, recovers automatically after fault condition is removed within 55% ~ 100% rated output voltage				
	OVER VOLTAGE	6.6 ~ 8.4V	16.5 ~ 21V	30 ~ 38V	55 ~ 60V	
		Protection type : Hiccup up mode, recovers automatically after fault condition is removed				
	OVER TEMPERATURE	Protection type : Hiccup up mode, recovers automatically after fault condition is removed				
	DC INPUT	REVERSE POLARITY	By internal Bridge Diode, no damage, recovers automatically after fault condition removed			
UNDER VOLTAGE LOCKOUT		Under voltage protection range: 120 ~ 130Vdc, Under voltage release range: 130 ~ 146.5Vdc				
FUNCTION	DC OK SIGNAL	Relay contact rating(max.) : 30V / 1A resistive				
ENVIRONMENT	WORKING TEMP.	-30 ~ +80°C (Refer to "Derating Curve")				
	WORKING HUMIDITY	20 ~ 90% RH non-condensing				
	STORAGE TEMP., HUMIDITY	-40 ~ +80°C, 10 ~ 95% RH non-condensing				
	TEMP. COEFFICIENT	± 0.03%/°C (0 ~ 55°C)				
	VIBRATION	Component: 10 ~ 500Hz, 3G 10min./1cycle, 60min. each along X, Y, Z axes; Mounting clip: Compliance to IEC60068-2-6				
	OPERATING ALTITUDE Note.5	5000 meters /OVc II				
	OVER VOLTAGE CATEGORY	II ; According to EN62109-1; altitude up to 5000 meters				
SAFETY & EMC (Note.7)	SAFETY STANDARDS	UL1741, CSA C22.2 No.107.1-16, IEC62109-1(LVD), EAC TP TC 004 approved				
	WITHSTAND VOLTAGE	I/P-O/P:4KVAC O/P-DC OK:0.5KVAC				
	ISOLATION RESISTANCE	I/P-O/P, 100M Ohms / 500VDC / 25°C / 70% RH				
	EMC EMISSION	Parameter	Standard		Test Level / Note	
		Conducted	BS EN/EN55032(CISPR32)		Class A	
		Radiated	BS EN/EN55032(CISPR32)		Class A	
		Voltage Flicker	BS EN/EN61000-3-3		-----	
	EMC IMMUNITY	BS EN/EN55035, BS EN/EN61000-6-2				
		Parameter	Standard		Test Level / Note	
		ESD	BS EN/EN61000-4-2		Level 3, 8KV air; Level 2, 4KV contact, criteria A	
Radiated Susceptibility		BS EN/EN61000-4-3		Level 3, 10V, criteria A		
EFT/Burest		BS EN/EN61000-4-4		Level 3, 2KV, criteria A		
Surge		BS EN/EN61000-4-5		Level 4, 2KV/Vin+ ~ Vin-, criteria A		
Conducted		BS EN/EN61000-4-6		Level 3, 10V, criteria A		
Magnetic Field		BS EN/EN61000-4-8		Level 4, 30A, criteria A		
	Voltage Dips and interruptions	BS EN/EN61000-4-11		> 95% dip 0.5 periods, 30% dip 25 periods, > 95% interruptions 250 periods		
OTHERS	MTBF	454.5K hrs min. MIL-HDBK-217F (25°C); 1439.7K hrs min. Telcordia TR/SR-332 (Bellcore) (25°C)				
	DIMENSION	57*93.5*105mm (W*H*D)				
	PACKING	0.8Kg; 16pcs/12.8Kg/0.84CUFT				
NOTE	<p>1. All parameters NOT specially mentioned are measured at 600Vdc input, rated load and 25°C of ambient temperature.</p> <p>2. Ripple & noise are measured at 20MHz of bandwidth by using a 12" twisted pair-wire terminated with a 0.1μF & 47μF parallel capacitor.</p> <p>3. Tolerance : includes set up tolerance, line regulation and load regulation.</p> <p>4. Derating may be needed under low input voltage. Please check the derating curve for more details.</p> <p>5. The ambient temperature derating of 3.5°C/1000m with fanless models and of 5°C/1000m with fan models for operating altitude higher than 2000m(6500ft).</p> <p>6. Installation clearances : 40mm on top, 20mm on the bottom, 5mm on the left and right side are recommended when loaded permanently with full power. In case the adjacent device is a heat source, 15mm clearance is recommended.</p> <p>7. The power supply is considered a component which will be installed into a final equipment. The final equipment must be re-confirmed that it still meets EMC directives. For guidance on how to perform these EMC tests, please refer to "EMI testing of component power supplies." (as available on https://www.meanwell.com/Upload/PDF/EMI_statement_en.pdf)</p> <p>※ Product Liability Disclaimer : For detailed information, please refer to https://www.meanwell.com/serviceDisclaimer.aspx</p>					

■ Block Diagram

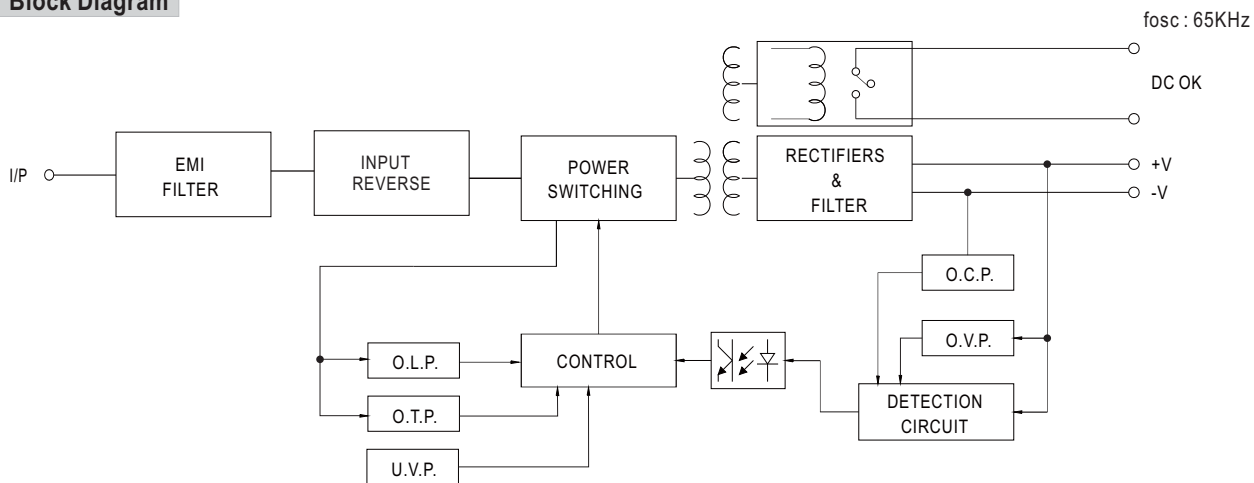

■ Derating Curve

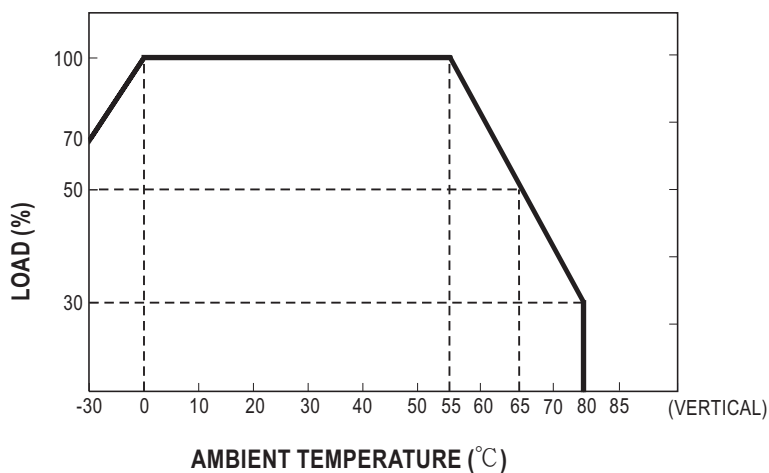

■ Static Characteristics

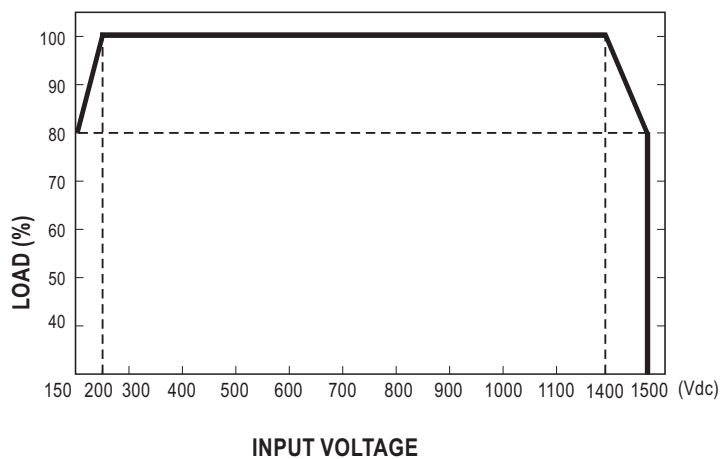

■ DC OK Relay Contact

Contact Close	PSU turns ON / DC OK.
Contact Open	PSU turns OFF / DC Fail.
Contact Ratings (max.)	30V/1A resistive load.

Mechanical Specification

(Unit: mm , tolerance ± 1 mm)

Case No.DDRH-60

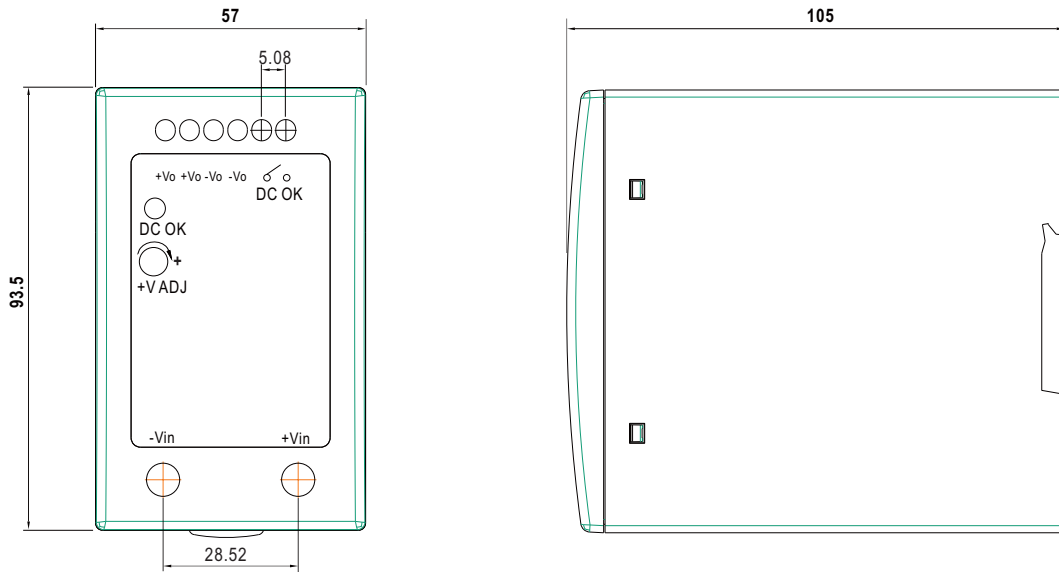

External FUSE wiring instruction

External FUSE is required.FUSE specification : 4A/1500Vdc.

Suggested model:

Fuse Brand	Manufacturer Part NO.		MW's Order NO.
	Fuse	Fuse Holder	Fuse + Fuse Holder
WalterFuse	WJ30-4	WJ30-H	WJ30-4_WJ30-H

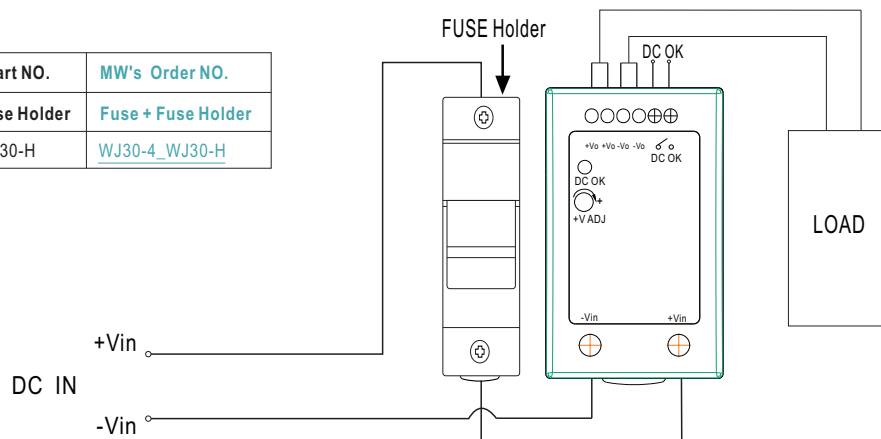

Installation Instruction

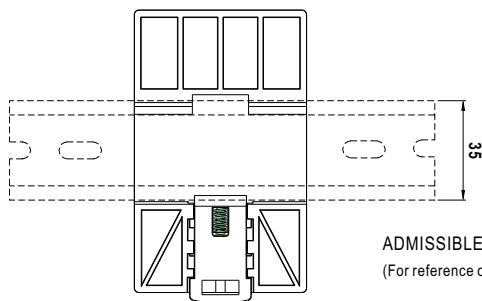

Back View

ADMISSIBLE DIN-RAIL:TS35/7.5 or TS35/15
(For reference only. Not included with unit.)

Installation Manual

Please refer to : <http://www.meanwell.com/manual.html>